

Cleaning technology – Municipal technology

Hako

Clean ahead



Citymaster 2200
Operating Manual

Issue: October 2016
Part number: 48600050012

Introduction

Foreword

Dear Customer,

We are certain that the excellent qualities of the vehicle will justify the faith you have shown in us by your purchase.

To guarantee you safe working with the vehicle, please read the Safety Notes chapter before putting it into service.

Your own safety, as well as the safety of others, depends essentially on your ability to control the vehicle. Please read this **original operating manual** before you use the vehicle for the first time, act accordingly and keep these instructions for future reference or subsequent users. The operating manual contains all important information for operation, maintenance and care. We have provided the places in this operating manual concerning your safety with a danger pictogram. Your authorised Hako dealer is available at all times to answer further questions about the vehicle or the operating manual.

We would expressly advise you that no legal claims may be asserted based on the contents of this operating manual. In the case of necessary repair work, please make sure that only original spare parts are used. Spare parts must be original spare parts to guarantee safety. We reserve the right to make changes in the interests of further technical development.

Hako GmbH
23843 Bad Oldesloe, Germany
Hamburger Str. 209-239
Phone +49 4531 806-0

Issue:

Index	Part number	Valid as from:	VIN
00	48600050012	October 2016	WMU2X56E6GWCM008

Applications

The Citymaster 2200 is a road sweeping machine for commercial and municipal use throughout the year. Thanks to special attachments, the Citymaster 2200 can be used for various applications.

- Vacuum sweeping system with sweeping unit, suction mouth and dirt hopper
Accessories: Trolley (option), hand suction hose (option), high-pressure cleaner (option) and weed brush (option)
- Winter service accessories: Snow blade 150 cm and 170 cm (option), sand and salt spreader, silo spreader (option) and front sweeping machine (option)

Your authorised Hako dealer will be pleased to inform you which attachments are possible and permissible for your vehicle. Any attachment must be approved by Hako.

Bear in mind the following when driving on public roads with attachments fitted:

- The legal regulations of your country, especially those concerning the use of attachments
 - The requirements specified in the licence certificate part 1 (former registration document) and the licence certificate part 2 (former identification document)
 - The axle loads and permissible total weight specified in the licence certificate part 1 and part 2
- In addition, bear in mind the mandatory regulations relevant to accident prevention (e.g. BGV D 29 in Germany).

Vehicle data

Your vehicle is described clearly by the following data. Please always quote these data in correspondence or when making a telephone query to your authorised Hako dealer or our company.

- Vehicle type: _____
- Chassis No.: _____
- Engine No.: _____
- Start-up on: _____

Please enter the data applicable to your vehicle in the list above. The data are immediately available in the case of enquiries or spare parts orders.

Your nearest authorised Hako dealer

- Address: _____

- Telephone: _____

Acceptance of the vehicle

Inspect the vehicle immediately on delivery for signs of transport damage. You will be compensated if the damage is immediately confirmed by the haulage contractor and the damage report is sent to our authorised Hako dealer together with the consignment note.

Driving licence

According to the old driving licence law in Germany, the Citymaster 2200 may be driven by drivers with the following classes of driving licence:

- Class 2: Motor vehicles over 7.5 tonnes
- Class 3: Motor vehicles up to 7.5 tonnes

According to the new driving licence law in Germany the Citymaster 2200 may be driven by drivers with the following classes of driving licence from 1.1.1999 onwards:

- Class C: Motor vehicles over 3.5 tonnes
- Class CE: Motor vehicles over 3.5 tonnes

In other countries, the corresponding national regulations must be complied with.

Equipment

According to § 53 StVZO the following equipment has to be kept with the vehicle in the Federal Republic of Germany (not included in the scope of supply):

- 1 warning triangle of approved type
- 1 warning light of approved type
- 1 warning vest
- 1 first aid kit corresponding at least to the requirements of DIN 13164, Sheet 1 standard. In other countries, the corresponding national regulations must be complied with.

Required documents

Within the Federal Republic of Germany, the following documents must always be available:

- Licence certificate (part 1) of the vehicle
- Valid driving license of the driver
- Operating manual (kept in the left-hand operating console)

In other countries, the corresponding national regulations must be complied with.

Vehicle inspection

- All occupational accident insurance schemes in the Federal Republic of Germany require a **safety inspection** of your vehicle according to BGV D 29, which must be made at least once annually by an expert. A inspection label should be attached to the vehicle in addition so that the driver knows when the next expert inspection is due.
- According to § 29 StVZO of the Federal Republic of Germany, a general inspection (**HU**) must be made regularly:
 - For vehicles of more than 3.5 t permitted overall weight every 12 months.

In other countries, the corresponding national regulations must be complied with.

Conditions for approval

The Citymaster 2200 can be registered as a road sweeping machine. The following equipment features are available:

- Fixing points for front-mounted equipment
- Fixing points for rear-mounted equipment
- Fixing points for attachments
- Work hydraulics system

The vehicle cannot be registered as a "towing vehicle" on account of its features.

Observe the relevant national regulations for your country.

Intended use

The Citymaster 2200 is a road sweeping machine intended for commercial and municipal use throughout the year and with the attachments approved by Hako it is suitable for mowing and sweeping, marketplaces and car parks and for snow clearing.

Any use extending beyond this is not intended use. The manufacturer is not liable for any damage resulting from this and the user alone bears the risk. Intended use also includes compliance with the operating, maintenance and servicing conditions specified by the manufacturer. The vehicle may be used, maintained and repaired only by persons who are familiar with this work and instructed about the dangers. The vehicle and its front-mounted equipment and attachments correspond by virtue of their design and construction as well as in the version distributed by us to the usual health and safety requirements of the EC Directives (see Declaration of Conformity). These documents lose their validity in the event of a modification not authorised by us. The manufacturer is not deemed liable for any damage resulting from unauthorised modifications to the machine.

Notes on warranty

The terms defined in the purchase agreement apply. Claims for compensation in relation to damage are excluded from the terms of the warranty when the damage is the result of the failure to observe rules concerning servicing and maintenance. Maintenance work must be carried out by authorised Hako dealers and confirmed in the "Maintenance Report", which serves as a warranty logbook. The following are excluded from the terms of warranty: wear and tear through overuse, defective fuses, improper handling and use and unauthorised modifications. Claims under the terms of the warranty are also annulled when damage occurs to the vehicle resulting from the use of parts or accessories not explicitly approved of by us or from failure to observe maintenance rules.

	Introduction	2
	Foreword	2
	Applications	3
	Vehicle data	3
	Acceptance of the vehicle	4
	Driving licence	4
	Equipment	4
	Required documents	4
	Vehicle inspection	4
	Conditions for approval	5
	Intended use	5
	Notes on warranty	5
1	Safety instructions	10
1.1	Marking of warning and danger symbols	10
1.2	General safety instructions	11
1.3	Operating safety instructions	12
1.3.1	Before putting into service	12
1.3.2	During operation	13
1.3.3	Stopping and parking the vehicle	14
1.3.4	Recovering and transporting the vehicle	14
1.4	Safety instructions for attachments	15
1.4.1	General	15
1.4.2	Ballast	15
1.4.3	Attachment – vacuum sweeping system	16
1.5	Safety instructions for maintenance and servicing	17
1.5.1	General	17
1.5.2	Protective devices	17
1.5.3	Engine	18
1.5.4	Fuel system	19
1.5.5	Exhaust gas purification system	20
1.5.6	Cooling system	21
1.5.7	Air filter	22
1.5.8	Hydraulic system	22
1.5.9	Gearbox	22
1.5.10	Brake system	23
1.5.11	Air conditioning system	23
1.5.12	Wheels and tyres	24
1.5.13	Windscreen washer unit	24
1.5.14	Electrical system	25
1.5.15	Vacuum sweeping system	25
1.5.16	Installation of electrical devices	26
1.6	Information about special risks	27
1.6.1	Exhaust gases	27
1.6.2	Re-fuelling the vehicle	27
1.6.3	Danger areas at the vehicle	27
1.6.4	Danger of tilting over	27
1.6.5	Suspended loads	27
1.6.6	Battery	28
1.6.7	Noise	28
1.6.8	Hydraulics	28
1.6.9	Operating and auxiliary materials	28
1.7	Environmental protection instructions	29
1.8	Shutting down and disposal	29
1.9	Labels on the vehicle	30

2	Operation	32
2.1	Overviews	32
2.1.1	Front view	34
2.1.2	Rear view	36
2.1.3	Vehicle cab	38
2.1.4	Roof console	40
2.1.5	Centre console	42
2.1.6	Hydraulic, water and electric connections	48
2.2	Overview of the most important controls	49
2.2.1	Battery master switch (option)	49
2.2.2	Jump-start socket (option)	49
2.2.3	Ignition switch	50
2.2.4	Indicating device	51
2.2.5	Multifunction display	56
2.2.6	Light and signal system	76
2.2.7	Windscreen washer unit	82
2.2.8	Heating and ventilation	83
2.2.9	Air conditioning system	85
2.2.10	Auxiliary heater (independent vehicle heating (option))	86
2.2.11	Driver's seat / Passenger seat	87
2.2.12	Seat belt	90
2.2.13	Steering column	92
2.2.14	Doors	93
2.2.15	EU control device (option)	93
2.2.16	Socket, cigarette lighter	94
2.2.17	Brakes	95
2.2.18	Steering	100
2.2.19	Drive	103
3	Operation	107
3.1	General Notes	107
3.1.1	Instruction	107
3.1.2	Running-in period	107
3.2	Driving the Citymaster 2200	108
3.2.1	Before start-up of the vehicle	108
3.2.2	Starting the vehicle and moving off	110
3.2.3	Stopping and parking the vehicle	116
3.2.4	Recovering and transporting the vehicle	119
3.3	Attachments in general	121
3.3.1	Ballast	121
3.3.2	Fitting the front-mounted equipment	122
3.3.3	Operating the front-mounted equipment	125
3.3.4	Fitting the attachment	128
3.3.5	Operating the attachment	129
3.4	Vacuum sweeping system	130
3.4.1	Mounting the suction mouth (2-brush system)	131
3.4.2	Mounting the suction mouth (3-brush system)	132
3.4.3	Mounting the sweeping unit (2-brush system)	133
3.4.4	Mounting the sweeping unit (3-brush system)	135
3.4.5	Mounting the dirt hopper	137
3.4.6	Before start-up of the vacuum sweeping system	141
3.4.7	Operating the vacuum sweeping system	143
3.4.8	Operating the vacuum sweeping system with the multifunction handle (option)	149
3.4.9	Hand suction hose (option)	150
3.4.10	High-pressure cleaner (option)	151
3.4.11	Cleaning the vacuum sweeping system	152

4	Technical data	159
4.1	Engine	159
4.2	Driving speeds and inclination values	159
4.3	Tyres	159
4.4	Weights and loads	160
4.5	Hydraulic system	160
4.6	Electrical system	160
4.7	Vacuum sweeping system	160
4.8	Vehicle dimensions	161
4.9	Noise emission values	162
4.10	Vibration values	162
5	Maintenance and servicing	163
5.1	Maintenance certificate	165
5.2	Maintenance plan	167
5.3	Lubrication plan	175
5.3.1	Lubrication work at the vehicle	175
5.3.2	Lubrication work at the vacuum sweeping system	176
5.4	Engine/vehicle fluids and lubricants	179
5.5	Accessibility to assemblies	180
5.5.1	Engine cover	181
5.5.2	Radiator cover	182
5.5.3	Side covers	183
5.5.4	Hydraulic hand pump	184
5.5.5	EMERGENCY manual control for hydraulics	185
5.6	Engine	186
5.6.1	Checking the engine oil	187
5.6.2	Topping up engine oil	188
5.7	Fuel system	189
5.7.1	Refuelling	190
5.8	Exhaust gas purification system	191
5.8.1	Diesel particle filter	192
5.8.2	Refuelling AdBlue	192
5.9	Cooling system	193
5.9.1	Checking the coolant level	194
5.9.2	Topping up the coolant	194
5.9.3	Cleaning the cooling system	195
5.9.4	Cleaning the cooling system with reversing fan (option)	195
5.10	Air filter	196
5.10.1	Checking the cyclone separator	196
5.10.2	Cleaning the filter insert	197
5.11	Hydraulic system	198
5.11.1	Checking the hydraulic oil level	199
5.11.2	Topping up the hydraulic oil	200
5.11.3	Changing the return filter	200
5.11.4	Hydraulic hose lines	201
5.12	Gearbox	202
5.13	Brake system	203
5.13.1	Checking the brake fluid	204
5.13.2	Topping up the brake fluid	204
5.14	Air conditioning system	205
5.14.1	Cleaning the condenser	206
5.14.2	Filling the air conditioning system	206
5.14.3	Cleaning the fresh air filter	207
5.15	Wheels and tyres	208
5.15.1	Checking the tyres	208

5.15.2	Changing wheels	209
5.16	Windscreen washer unit	211
5.16.1	Checking the windscreen washer unit	211
5.16.2	Topping up the windscreen washer unit	211
5.17	Electrical system	212
5.17.1	Battery	213
5.17.2	Fuses	214
5.17.3	Lamps	218
5.18	Vacuum sweeping system	222
5.18.1	Safety strut	222
5.18.2	Presetting 3rd brush	223
5.18.3	Checking the sweeping level (2-brush system)	224
5.18.4	Checking the sweeping level (3-brush system)	225
5.18.5	Checking the suction mouth sealing strips (2-brush system)	226
5.18.6	Checking the suction mouth sealing strips (3-brush system)	227
5.18.7	Seal at the suction duct	228
5.18.8	Seal at the dirt hopper	228
5.19	General service and maintenance work	229
5.19.1	Vehicle cleaning	229
5.19.2	Special tightening torques	231
5.19.3	Screw connections	231
5.20	Troubleshooting	232
5.20.1	Troubleshooting at the vehicle	232
5.20.2	Troubleshooting at the vacuum sweeping system	235
	Declaration of conformity.....	237

1 Safety instructions

1.1 Marking of warning and danger symbols

Important tasks concerning the safety of the operator and vehicle are named as follows in this operating manual and emphasised by symbols.



Danger

Indication of a direct danger with high risk, in which death or severe physical injury can occur if it is not avoided.



Warning

Indication of a possible danger with average risk, in which death or severe physical injury can occur if it is not avoided.



Caution

Indication of a danger with low risk, in which light to medium severe physical injury or material damage can occur if it is not avoided.



Attention

Attention indicates a hazard that can lead to technical damage when not heeded.



Environmental danger

Environmental danger due to the use of substances from which a health and environmental risk proceeds.



Note

Indication of information that facilitates more effective and economical use of the vehicle.

1.2 General safety instructions

**Note**

- Apart from the instructions in this operating manual, the general safety and accident prevention regulations of the legislation must be taken into account.
- Before the vehicle is put into service, please read carefully the operating manual you receive as well as further separate instructions for additional implements or attachments and observe them in all aspects in your work.
- The operating manual must always be to hand at the place of use of the vehicle, and must therefore be kept in the vehicle cab. Immediately complete or replace an incomplete or illegible operating manual.
- The vehicle may be used, maintained and repaired only by persons who have been instructed by Hako experts.
- This device may not be used by persons (including children) with reduced physical or mental abilities or by persons without sufficient experience and skills.
- You should pay special attention to the safety instructions. For errors in operating the vehicle can be avoided and trouble-free operation can be guaranteed only with precise factual knowledge.
- Please hand over these documents as well as the licence certificates to the new owner/operator on sale or rental of the vehicle. Have the hand-over confirmed!
- The labels attached to the vehicle provide important information for safe operation. Renew labels that are no longer legible or present.
- The licence certificate (part 1), valid driver's license of the vehicle driver and the operating manual must be present constantly at the place of use of the vehicle and should therefore be kept carefully in the driver's cab.
- Spare parts must be original spare parts to guarantee safety.

1.3 Operating safety instructions

1.3.1 Before putting into service



Danger

- Always switch on the lights when visibility is poor and after dark. There is a risk of accidents!
- Good viewing conditions contributing to traffic safety are guaranteed only if all windows are free of ice, snow and condensation. There is a risk of accidents!
- Never change the seat position when driving. Adjust the seat before moving the vehicle. There is a risk of accidents!
- Driving with the head rest set incorrectly means risk of injury!
- Driving or working without the seat belt means risk of injury! The seat belt will be stretched after an accident, and can no longer be used. Therefore, in the event of another accident, this overstretched seat belt will not provide sufficient safety.
- There is a risk of accidents when adjusting the steering column when driving or while driving with the steering column unlocked.
- There is a risk of accidents when driving with open doors!
- There is a risk of accidents when driving with unadjusted outside rearview mirrors!
- Dirt accumulation in the area of the brake pedal can result in brake malfunctions. There is a risk of accidents!

Warning

- The vehicle must only be used when in technically perfect condition in accordance with its designated use and the instructions set out in the Operating Manual, and only by persons who are aware of the risks and safety factors involved. Rectify (or have rectified) any functional disorders immediately, especially those affecting the safety of the vehicle.
- Before starting work, the operator must familiarize himself with all equipment, operating and actuating elements as well as with their function. It is too late to do this during operation!
- Before starting work, familiarise yourself with the working environment at the work site. The working environment includes, for example, any obstacles in the working and traffic area, the load-bearing capacity of the ground, and any necessary barriers separating the work site from public roads.
- A warning triangle, a warning light, a warning vest and a first aid kit must be in the vehicle during operation.
- Sturdy and slip-proof shoes must be worn when working with the vehicle.
- Only use the footholds and handles provided when entering and leaving the cab!
- Never use the controls or mobile cables as handles!
- Never climb onto or jump off a moving vehicle!
- Passengers must only sit on the passenger seats provided for this purpose. Never carry persons on the tipper or on implements and attachments.
- Only those surfaces approved by the contractor or its authorised representative for use of the vehicle may be driven on.
- The vehicle is not suitable for removing dangerous, combustible or explosive liquids, dusts or materials.
- Observe the maximum gradability of the vehicle, see Technical data.

1.3.2 During operation



Danger

- It is not permitted to stand underneath the dirt hopper if it is not secured. Always fit the safety strut whenever working underneath the dirt hopper. There is a danger to life!
- Special caution is required in the area of the front and rear-mounted equipment and attachments. There is a danger to life!
- Inhaling exhaust gases is injurious to health and can lead to unconsciousness and to death! Never let the engine run in enclosed spaces. Danger to life due to toxic engine exhaust gases.
- Avoid sudden turns when driving uphill or downhill or across slopes. Danger to life due to the vehicle tipping over in an inclined position! The vehicle speed must always be adapted to the surrounding conditions and the load condition.
- The power brake does not work when the engine is switched off or in the event of a brake circuit failure. The brake pedal has to be pressed much harder. Take this into account, especially when towing the vehicle. There is a risk of accidents!
- Strong hydrostatic braking effect when abruptly changing direction. There is a risk of accidents
- Relying on the anti-blocking system (ABS) to shorten the braking distances should not lead to a careless driving style. It is primarily designed as a safety reserve in emergency situations. ABS is also not capable of overcoming physical limits. This must be taken into account, especially when the road is slippery or wet. There is a risk of accidents!
- Note that there is a risk of skidding on unpaved ground or snow and ice. This can lead to uncontrolled behaviour of the vehicle. Drive correspondingly carefully! There is a risk of accidents!
- Turning the steering wheel requires greater effort if the power steering fails – emergency steering. Take this into account, especially when towing the vehicle. There is a risk of accidents!
- Switch over the steering type only when the vehicle is standing. There is a risk of accidents!

Warning

- For reasons of safety, the vehicle is equipped with a seat contact switch and the function of the seat contact switch must not be bypassed.
- In the case of restricted vision, especially when reversing the vehicle, it is necessary to have a second person who gives the driver appropriate signals. The second person must always be in the field of view of the driver.
- When working with the vehicle, pay special attention to third persons, especially children.
- In transport journeys on public roads the working spotlights must be switched off.
- When driving underneath underpasses, bridges, tunnels or overhead lines, always make sure that there is sufficient clearance.
- Always maintain sufficient distance from the edges of building pits and slopes.

1.3.3 Stopping and parking the vehicle

	<p>Danger</p> <ul style="list-style-type: none"> • Only use the parking brake instead of the service brake in an emergency, i. e. if the service brake is out of operation. The brake lights will not light up in this case. There is a risk of accidents! • Adopt measures against erroneous starting and unwanted movement. There is a risk of accidents! • The vehicle must be parked on firm ground. On inclinations secure the vehicle additionally against rolling away with a wheel chock. There is a risk of accidents! • The diesel particle filter and the SCR catalytic converter get very hot. Risk of fire and burns! <ul style="list-style-type: none"> • Do not reach into the area of the exhaust outlet. Keep children and other persons away from this area. • When operating the vehicle, make sure that no easily inflammable materials are in the direct vicinity of the exhaust system, especially the exhaust pipe. • When parking the vehicle while the engine is running, make sure that no inflammable or combustible materials (e.g. paper, dry grass, straw, wood, wooden building materials, oil, fuels, etc.) are in the direct vicinity of the exhaust outlet. • Do not park the vehicle in high dry grass. Never use additional underbody sealant or anti-corrosive agents for exhaust pipes, heat shields or the diesel particle filter. These could ignite when the engine is hot.
---	--

1.3.4 Recovering and transporting the vehicle

	<p>Danger</p> <ul style="list-style-type: none"> • Start driving slowly! Make sure that there are no persons in the towing area. There is a danger to life! • The vehicle may be loaded only using suitable loading aids, such as a loading ramp or drive-up planks. There is a risk of injury! • After loading, make sure that the vehicle is secured according to regulations against rolling off and tilting. There is a risk of injury! Use the wheels for securing the vehicle. • Power steering does not work when the diesel engine is switched off – emergency steering. Steering will then require more force. There is a risk of accidents! • The power brakes do not work when the engine is switched off. The brake pedal has to be pressed much harder. Take this into account, especially when towing the vehicle. There is a risk of accidents! <p>Warning</p> <ul style="list-style-type: none"> • Always recover the damaged vehicle rearwards! There are no suitable fixing points at the front of the vehicle. • The vehicle must only be recovered using suitable equipment (ropes or bars) in conjunction with suitable fixing points, such as couplings, hooks and eyes. • The vehicle can be recovered using a rope when the service brake and the steering system are still fully functional. • Observe the permissible maximum distances and speeds during recovery!
---	--

	<p>Danger</p> <ul style="list-style-type: none"> • Remove any mud, snow and ice from the tyres so that the vehicle can be driven safely onto the ramps. There is a risk of injury! <p>Warning</p> <ul style="list-style-type: none"> • The transport vehicle must be of adequate size. Refer to the "Technical data" section for the dimensions and weights of the vehicle. • The vehicle may be loaded only using suitable loading ramps or drive-up planks. • Secure the vehicle against unintentional movement on the transport vehicle!
---	---

1.4 Safety instructions for attachments

1.4.1 General

	<p>Danger</p> <ul style="list-style-type: none"> • Special care is required when working in the danger zone of the vehicle, particularly at the front and rear-mounted equipment and attachments. There is a danger to life! • You must consult Hako before attaching other attachments not approved by Hako! Check in the individual case that the relevant axle loads and total weights are complied with. There is a risk of accidents! • Put the attachment into service only if all protective devices are attached and in protection position. There is risk of injury! • Make sure that the attachments are suitable for the set oil volume. An oil volume set too high can lead to injuries due to a defect of the attachment! There is a risk of injury! • Pressure hoses, fittings and couplings are important for equipment safety. Use only pressure hoses, fittings and couplings recommended by the manufacturer. There is a risk of injury! • When connecting attachments to the hydraulic system, ensure that the hydraulic hoses are connected correctly. Swapping the connections can lead to reverse functioning of the attachment, e.g. movement to the right rather than the left. There is a risk of injury! • Front attachments not correctly fastened to the front tool carrier can drop down while driving. Always secure the front attachment with the locking devices. There is a risk of accidents! • Handling, steering and braking as well as stability are influenced by attachments, trailers and the vehicle payload (e.g. full dirt hopper). For this reason, pay attention to adequate steering and braking capability as well as stability. There is a risk of accidents! • In Germany, if attachments extend beyond the outer lighting equipment of the vehicle or if the maximum distances of the outer lighting equipment specified according to StVZO are exceeded, the lighting equipment of the vehicle must be repeated (see information leaflet StVZO § 30, explanations 11 and 12). There is a risk of accidents! <p>Attention</p> <ul style="list-style-type: none"> • Observe the operating manual for the attachment.
---	---

1.4.2 Ballast

	<p>Danger</p> <ul style="list-style-type: none"> • When attaching other attachments not approved by Hako, consult Hako as to whether the relevant axle loads and total weights are complied with! There is a risk of accidents! • The attachment of front and rear attachments must not lead to exceeding the permissible total weight, the permissible axle load and the tyre load capacity of the working machine! There is a risk of accidents! <p>Attention</p> <ul style="list-style-type: none"> • Make sure before purchasing the attachment that these requirements are fulfilled by weighing the working machine attachment combination!
---	--

1.4.3 Attachment – vacuum sweeping system



Danger

- Special care is required when working in the danger zone of the vehicle, particularly at the front and rear-mounted equipment and attachments. There is a danger to life!
It is not permitted to stand underneath the dirt hopper if it is not secured. Always fit the self-activating safety strut whenever working underneath the dirt hopper. There is a danger to life!
- Avoid sudden turns when driving uphill or downhill or across slopes. Danger to life due to the vehicle tipping over in an inclined position! The vehicle speed must always be adapted to the surrounding conditions and the load condition.
- Make transport journeys only with a raised sweeping unit and with a completely lowered dirt hopper. There is a risk of accidents!
- The stability of the vehicle is influenced by a filled dirt hopper. Handling of the vehicle must be adapted accordingly. There is a risk of accidents!
- Do not exceed the permissible total weight of the vehicle! There is a risk of accidents!
- When the dirt hopper is emptied, the Citymaster 2200 must be on a sufficiently load bearing, horizontal surface. Driving with the dirt hopper tilted is not permitted. There is a risk of accidents!
- The jet of the high-pressure cleaner (option) must not be directed to persons. There is a risk of injury!

Caution

- The vacuum sweeping system may be operated only in connection with the Citymaster 2200. The safety regulations for the Citymaster 2200 must be complied with absolutely.

Attention

- When removing blockages in the suction hose or attaching the hand suction hose (option), switch off the engine and wait for the suction fan to come to a standstill.
- The vacuum sweeping system must be cleaned at least once a day, or more often in case of heavy soiling.
- Do not use steam cleaners and high-pressure cleaners (option) for cleaning electrical/electronic components and the engine compartment!

1.5 Safety instructions for maintenance and servicing

1.5.1 General

	<p>Danger</p> <ul style="list-style-type: none"> • It is not permitted to stand underneath the dirt hopper if it is not secured. Always fit the safety strut whenever working underneath the dirt hopper. There is a danger to life! • Special caution is required in the area of the front and rear-mounted equipment and attachments. There is a danger to life! • Perform maintenance and repair work under a jacked up vehicle or attachment only if it is safely and securely supported (hydraulic cylinders, jacks, etc. alone do not secure a jacked-up vehicle). There is a risk of injury! • Do not perform any welding, drilling, sawing or grinding work on parts of the frame. Damaged parts may be replaced only by your authorised Hako dealer. There is a risk of accidents! • Adopt measures against erroneous starting and unwanted movement. Operate the parking brake. Switch the engine off and pull out the ignition key. There is a risk of accidents! • If dismantling safety devices is required in equipping, maintenance and repair work, fit and check the safety devices immediately after completion of the work. There is a risk of accidents! <p>Attention</p> <ul style="list-style-type: none"> • Daily and weekly maintenance work must be done by the operating staff. In all other maintenance work, please contact your nearest authorised Hako dealer. • Apart from the regular general inspection, the vehicle and the attachments must be maintained at regular intervals according to BGV, D 29 and be checked at least annually for operationally safe condition. • Spare parts must be original spare parts to guarantee safety. • Use suitable tools for the cleaning and maintenance work. • Do not use steam cleaners and high-pressure cleaners (option) for cleaning electrical/electronic components and the engine compartment! • After cleaning, examine all fuel, engine oil and hydraulic pipes for leaks, abrasion places and damage. Immediately rectify any damage found! • Always tighten screw connections loosened in maintenance and repair work.
---	--

1.5.2 Protective devices

	<p>Danger</p> <ul style="list-style-type: none"> • It is not permitted to stand underneath the dirt hopper if it is not secured. Always fit the safety strut whenever working underneath the dirt hopper. There is a danger to life! • Special caution is required in the area of the front and rear-mounted equipment and attachments. There is a danger to life! • Put the vehicle into service only if all protective devices are attached and in protection position. There is a risk of injury! • Do not touch any parts such as engine block, cooling system and exhaust system during operation and for some time after. There is a risk of burns!
---	--

1.5.3 Engine

**Danger**

- Inhaling exhaust gases is injurious to health and can lead to unconsciousness and to death! Never let the engine run in enclosed spaces. Danger to life due to toxic engine exhaust gases.
- Do not touch any parts such as engine block, cooling system and exhaust system during operation and for some time after. Allow the engine to cool down. There is a risk of burns!
- Risk of injury to limbs or of hair or clothing getting caught up in rotating parts. Switch the engine off and pull out the ignition key. There is a risk of burns!

Attention

- If the engine oil pressure warning symbol in the multifunction display lights up with the engine running, there is a risk of engine damage! Stop the vehicle in the safe area. Turn the engine off immediately and check the oil level. Have the cause of the inadequate engine oil pressure removed.
- Excessive or incorrect engine oil may result in engine damage. For this reason:
 - Do not add engine oil to above the MAX marking on the oil dipstick.
 - Use only the specified engine oil, see Operating materials and lubricants.

Environmental danger

- Ensure safe and environment-conserving disposal of operating and auxiliary materials. Take up escaping or spilled operating materials in suitable containers and dispose of them in an environmentally friendly manner.

1.5.4 Fuel system



Danger

- Risk of fire! Diesel fuel is flammable! Take the utmost care when handling fuel. Never refuel close to naked flames or ignitable sparks. Do not smoke during fuelling. Switch off the engine, pull out the ignition key and engage the parking brake before fuelling. Do not refuel in enclosed spaces. Keep the vehicle clean to reduce the risk of fire. When working on the fuel system, ensure that everything is extremely clean.
- Risk of scalding! Due to the high fuel pressures in the injection system, the fuel can reach higher temperatures, especially when the fuel level in the fuel tank is low.
- The diesel particle filter and the SCR catalytic converter get very hot. Risk of fire and burns!

Attention

- The vehicle cannot be operated with PME fuels (vegetable oil methyl ester). PME fuels have not been tested or approved by Hako GmbH and could impair the safety of the vehicle. Hako GmbH is not liable for damage resulting from this misuse. Use only commercially available diesel fuel to refuel the vehicle. Otherwise, the fuel system will be damaged or reliable diesel particle filter regeneration will no longer be guaranteed. Operation with rape seed oil or biodiesel fuel (RME/ PME) or vegetable oil is not permitted.
- Do not start the vehicle when the fuel tank is empty. This may damage the rail pressure system. Never let the fuel tank run dry. Always refuel the vehicle in good time. If the fuel tank has run dry, bleed the fuel system before starting. Have this done by an authorised workshop!
- If petrol or supergrade petrol was accidentally used for refuelling, the engine must not be started, as damage could otherwise occur. Have the fuel system drained by an authorised workshop with consideration of the environmental regulations and fill again with diesel fuel.
- Fuel additives (for improving flow) and similar agents must not be added to the diesel fuel.
- The use of diesel fuels with high sulphur content can considerably reduce the service life of the diesel particle filter. Ask your authorised workshop for information on the countries in which high concentrations of sulphur are found in diesel fuel.

Environmental danger

- Ensure safe and environment-conserving disposal of operating and auxiliary materials. Take up escaping or spilled operating materials in suitable containers and dispose of them in an environmentally friendly manner.
- Never refuel up to the upper edge of the filler opening – the fuel expands under heat and can overflow.

1.5.5 Exhaust gas purification system



Danger

- Do not touch any parts such as engine block, cooling system and exhaust system during operation and for some time after. There is a risk of burns! Allow the engine to cool down.
- The diesel particle filter and the SCR catalytic converter get very hot. Risk of fire and burns!
 - Do not reach into the area of the exhaust outlet. Keep children and other persons away from this area.
 - When operating the vehicle, make sure that no easily inflammable materials are in the direct vicinity of the exhaust system, especially the exhaust pipe.
 - When parking the vehicle while the engine is running, make sure that no inflammable or combustible materials (e.g. paper, dry grass, straw, wood, wooden building materials, oil, fuels, etc.) are in the direct vicinity of the exhaust outlet.
 - Do not park the vehicle in high dry grass. Never use additional underbody sealant or anti-corrosive agents for exhaust pipes, heat shields or the diesel particle filter. These could ignite when the engine is hot.

Attention

- If the diesel particulate filter in the multifunction display lights up red, the vehicle engine must be switched off immediately. Serious engine damage can be caused if this is not complied with.
- Use only commercially available AdBlue to refuel the vehicle. Otherwise, the exhaust system will be damaged or reliable cleaning will no longer be guaranteed. Only use AdBlue as per ISO 22241 or DIN 70070.
- Do not dilute AdBlue and do not add additives.
- In the event of malfunctions and damages at the exhaust gas purification system resulting from the application of AdBlue that does not meet the specifications and non-observance of this information, no warranty claims will be acknowledged.
- If exposed to intense heat above 50 °C (e.g. due to sunshine) over a longer period of time, ammonia may be released resulting in a pungent smell. Do not inhale escaping vapours when opening the tank. Ammonia vapours in this concentration are, however, not detrimental to health.
- Wipe the surfaces of components which might come into contact with AdBlue, e.g. when topping up, immediately with water.
- When refuelling AdBlue, always observe the information on topping up volumes as the tank could burst due to overfilling and low outside temperatures.
- The vehicle is equipped with an AdBlue preheating system which ensures operation of the exhaust gas purification system at temperatures below -11 °C. If the vehicle is used in regions where outside temperatures are always below -10 °C, install special measures to ensure correct AdBlue dosage and trouble-free engine operation.
- When refuelling using a pump nozzle with automatic shutoff, there is no risk of overfilling as the supply is stopped automatically when the max. permissible tank volume has been reached. When refuelling from canisters, always observe the topping up volume and avoid overfilling.

Environmental danger

- Ensure safe and environment-conserving disposal of operating and auxiliary materials. Take up escaping or spilled operating materials in suitable containers and dispose of them in an environmentally friendly manner.

1.5.6 Cooling system



Danger

- The cooling system is under pressure. If the cooling system cap is opened with a hot engine there is a risk of scalding. Allow the engine to cool down.
 - Wait at least 10 minutes after switching off the engine.
 - Wear protective gloves and clothing.
 - Always start by actuating the safety valve in the expansion tank filler cap; to do this, open the filler cap to the first notch and allow the pressure to escape.
- Risk of injury to limbs or of hair or clothing getting caught up in rotating parts. Switch the engine off and pull out the ignition key. There is a risk of injury!
- Never switch on the reversing fan (option) in the vicinity of people or in road traffic. Make sure there are no persons or vehicles in the direct vicinity of the vehicle. Only switch on the reversing fan in open spaces. There is a risk of accidents!

Attention

- Small air bubbles can form when the radiator is filled. Therefore the cooling system must be vented at the same time. Have this done by an authorised workshop!
- Be careful when cleaning the radiator with a high-pressure cleaner or steam jet. The radiator fins are made of 0.1-mm-thick sheet metal and can be easily damaged. Make sure that the nozzle is not closer than 30 cm to the radiator fins.
- The coolant additive and the coolant are detrimental to health. Therefore, store the coolant additive in the original container and take particular care to ensure that it is kept out of the reach of children.
- Dirt on the radiator fins reduces the radiator's heat dissipation capacity. Therefore:
 - Clean the outside of the radiator at regular intervals.
 - In dusty or dirty working conditions, clean more frequently than indicated in the maintenance plans.
- An insufficient coolant level reduces the heat dissipation capacity as well, and can lead to engine damage. Therefore:
 - Check the cooling level at regular intervals, see maintenance plan.
 - If coolant must be added frequently, check the cooling system for leaks and/or seek advice from your authorised workshop.
 - Never fill up with cold water/coolant if the engine is warm.
 - After filling the radiator, test-run the engine and check the coolant level again after switching off the engine.
- Using the wrong coolant can destroy the engine and radiator. Therefore:
 - Only use additives with VM specification for the radiator, see Operating materials and lubricants.
 - Do not use radiator cleaning agents if an antifreeze compound has been added to the coolant, as this causes sludge to form, which can damage the engine.

Environmental danger

- Ensure safe and environment-conserving disposal of operating and auxiliary materials. Take up escaping or spilled operating materials in suitable containers and dispose of them in an environmentally friendly manner.

1.5.7 Air filter

	<p>Danger</p> <ul style="list-style-type: none">• Do not touch any parts such as engine block, cooling system and exhaust system during operation and for some time after. Allow the engine to cool down. There is a risk of burns! <p>Attention</p> <ul style="list-style-type: none">• We can assume no liability for cleaned filter inserts. Never let the engine run without a filter insert!• Only replace the safety cartridge, do not clean it! Never let the engine run without safety cartridge! <p>Environmental danger</p> <ul style="list-style-type: none">• Ensure safe and environment-conserving disposal of operating and auxiliary materials. Take up escaping or spilled operating materials in suitable containers and dispose of them in an environmentally friendly manner.
---	---

1.5.8 Hydraulic system

	<p>Danger</p> <ul style="list-style-type: none">• Do not touch any parts such as engine block, cooling system and exhaust system during operation and for some time after. Allow the engine to cool down. There is a risk of burns!• Hydraulic oil issuing under high pressure can penetrate the skin and cause severe injuries. Therefore, even with the smallest wounds, consult a doctor since otherwise severe infections can arise! There is a risk of burns! <p>Warning</p> <ul style="list-style-type: none">• Work on the hydraulic system of the vehicle may be done only by persons with special knowledge and experience in hydraulics.• Regularly check all pipes, hoses and screw connections for leaks and external visible damage. Immediately rectify damage and leaks. Oil squirting out can cause injuries and fires. Observe the recommended replacement intervals for hydraulic pipes. With normal requirements 6 years, with increased requirements on safety 2 years!• Do not change over hydraulic pipes! Fittings and the length and quality of the hose line must comply with the requirements. <p>Environmental danger</p> <ul style="list-style-type: none">• Ensure safe and environment-conserving disposal of operating and auxiliary materials. Take up escaping or spilled operating materials in suitable containers and dispose of them in an environmentally friendly manner.
---	--

1.5.9 Gearbox

	<p>Attention</p> <ul style="list-style-type: none">• Depending on the respective function, the gearboxes of the Citymaster 2200 are filled with different oil grades. Therefore, do not try to correct the oil levels yourself as incorrect oil can result in considerable damage. Always seek advice from an authorised workshop when detecting leaks. <p>Environmental danger</p> <ul style="list-style-type: none">• Ensure safe and environment-conserving disposal of operating and auxiliary materials. Take up escaping or spilled operating materials in suitable containers and dispose of them in an environmentally friendly manner.
---	---

1.5.10 Brake system

	<p>Danger</p> <ul style="list-style-type: none"> • Repair work on the brake system must only be carried out by an authorised workshop. There is a risk of accidents! • Caution when handling brake fluid. There is a risk of poisoning! Keep the brake fluid in the closed original container only, and keep out of the reach of children. • Brakes are top-priority safety components; incorrect work can cause brake failure. All maintenance work performed on the brake system must be carried out by trained personnel. This does not include the following tasks, which must be performed by the operator of the vehicle: <ul style="list-style-type: none"> • Check the level in the brake fluid tank • Check the brake system daily for effectiveness, before starting to drive <p>Attention</p> <ul style="list-style-type: none"> • Contamination of the brake fluid can cause the brake system to fail! When working on the brake system, ensure that everything is extremely clean! • Prevent brake fluid from coming into contact with the paintwork of the vehicle, as this may cause the paint to dissolve. • Do not use mineral oil based brake fluid. • Only use original brake fluid for topping up, see Engine/vehicle fluids and lubricants. <p>Environmental danger</p> <ul style="list-style-type: none"> • Ensure safe and environment-conserving disposal of operating and auxiliary materials. Take up escaping or spilled operating materials in suitable containers and dispose of them in an environmentally friendly manner.
---	---

1.5.11 Air conditioning system

	<p>Danger</p> <ul style="list-style-type: none"> • Caution when handling coolant – There is a risk of poisoning! Avoid any contact with the coolant. Have maintenance work on the air conditioning system done only by trained personnel. <ul style="list-style-type: none"> • Do not open the refrigeration circuit. • If splashed into the eyes, rinse immediately with fresh water and consult a doctor immediately. • Do not perform welding on parts of the refrigeration circuit or in their immediate vicinity. • Keep the coolant in the closed original container only, and keep out of the reach of children. <p>Attention</p> <ul style="list-style-type: none"> • Have the air conditioning system checked every two years, preferably in spring, by an authorised workshop. Maintenance intervals, see maintenance plan. Lubricant specification, see Engine/vehicle fluids and lubricants. <p>Environmental danger</p> <ul style="list-style-type: none"> • Ensure safe and environment-conserving disposal of operating and auxiliary materials. Take up escaping or spilled operating materials in suitable containers and dispose of them in an environmentally friendly manner.
---	--

1.5.12 Wheels and tyres



Danger

- Repair work on wheels and tyres must only be carried out by an authorised workshop. There is a risk of accidents!
- Damaged tyres and/or incorrect tyre pressure reduce the operating safety of the vehicle. There is a risk of accidents!
- Due to the greater deformation with a lower tyre pressure, there is a risk of the vehicle tilting to the left and right. There is a risk of accidents!
- New tyres do not have optimum adhesion and should therefore be run in for about 100 kilometres whilst driving carefully. There is a risk of accidents!
- Worn tyres mean worse grip on the road, especially in wet conditions. Therefore, they should be replaced when the tread depth is down to 3 mm. Tyres older than 6 years must not be used. There is a risk of accidents!
- Check the wheel bolts regularly to ensure that they are securely tightened. Check the wheel bolts 50 km after a tyre change, and tighten if necessary. There is a risk of accidents!

Attention

- Depending on the version, the wheel weighs between 30 and 48 kg. If necessary, ask a second person for help or use suitable lifting equipment. There is a risk of injury!
- When changing wheels, make sure that the lifting equipment is applied to the specified jacking point.
- Should the wheel size change, it must be reset by an authorised workshop in the vehicle. This is the only way to ensure that the drive control unit and ABS are functioning reliably and safely.
- Only use tyres approved by Hako, see Technical data.

Environmental danger

- Ensure safe and environment-conserving disposal of old tyres.

1.5.13 Windscreen washer unit



Attention

- If insufficient antifreeze has been added, the windscreen washer fluid can freeze and destroy the motor of the windscreen washer unit. Observe the correct mixing ratio when mixing the washer fluid with the additive or antifreeze. Refer to the manufacturer's instructions on the additive or antifreeze packaging.

Environmental danger

- Ensure safe and environment-conserving disposal of operating and auxiliary materials. Take up escaping or spilled operating materials in suitable containers and dispose of them in an environmentally friendly manner.

1.5.14 Electrical system

	<p>Danger</p> <ul style="list-style-type: none"> • Work on the electrical system may be done only in accordance with electrical engineering standards by a specialist trained for this work. • Welding work on the vehicle may be done only by authorised Hako dealers. Welding work on the vehicle leads to damage to the control electronics and can impair driving safety. • Danger of explosion due to smoking, fire or open light! Especially when being charged, but also in the normal use of batteries, batteries emit explosive gases! Avoid smoking, fire, sparks or open light in the vicinity of batteries! • Danger of explosion due to sparks! Never place tools or other electrically conductive objects on the battery! Sparks that can ignite escaping gases arise if the poles are short-circuited. • Danger of explosion due to frozen battery or too low acid level! With a frozen battery or if the acid level is too low, do not attempt to start with a jumper cable, the battery can burst or explode. • Danger of burns due to battery acid! The special safety and accident prevention regulations must be complied with when handling the battery. Batteries contain sulphuric acid. Only store battery acid in the closed original container, and keep out of the reach of children. • Risk of fire! When carrying out work on the fuses, switch off the electrical system to disconnect the consumers from the power supply. Use only original fuses. If stronger fuses are used, the electrical system can be destroyed and there can be fires. <p>Attention</p> <ul style="list-style-type: none"> • Always disconnect the battery when working on the electrical system or when performing welding work. • Always observe the correct order when connecting and disconnecting the battery! <ul style="list-style-type: none"> • Disconnecting the battery: First the minus pole and then the plus pole! • Connecting the battery: First the plus pole and then the minus pole! • After every maintenance task involving disconnecting the battery, make sure that the clamps are firmly seated on the terminals on re-connection. • Disconnect the battery from the vehicle electrical circuits before recharging the battery. Do not disconnect the battery while the engine is running. Observe the precautions in the usage instructions and the product description for the battery. Do not use a battery charging device to start the engine. • Note the operating voltage of the vehicle! • Check the vehicle's electrical equipment at regular intervals. Defects such as loose connections or scorched cables must be removed immediately. • Before replacing a light bulb, switch off the ignition to disconnect the consumers from the power supply. Only ever replace light bulbs with new ones with the same version and rating (amperage). Do not touch the glass bulb of the halogen light with your bare fingers. <p>Environmental danger</p> <ul style="list-style-type: none"> • Used batteries with the recycling symbol contain reusable commodities. In accordance with the symbol showing the crossed-out garbage bin, these batteries must not be disposed of in the domestic waste. Return and recycling have to be arranged with the authorised Hako dealer as required in § 6 and § 8 of the German battery law (BattG)!
---	--

1.5.15 Vacuum sweeping system

	<p>Danger</p> <ul style="list-style-type: none"> • It is not permitted to stand underneath the dirt hopper if it is not secured. Always fit the safety strut whenever working underneath the dirt hopper. There is a danger to life! • Special caution is required in the area of the front and rear-mounted equipment and attachments. There is a danger to life!
---	---

1.5.16 Installation of electrical devices

General



Attention

- The vehicle is equipped with electronic components and parts whose function can be influenced by electromagnetic emissions of other devices. Such influence can lead to danger to persons and safety-relevant functions if the following safety instructions are not complied with:
- If electrical and electronic devices and/or components, which also are connected to the vehicle electrical system, are installed subsequently in the vehicle, the user must examine in his own responsibility whether the installation causes interference to the vehicle electronics or to other components, a renewed acceptance test may be necessary.
- Above all it must be ensured that the subsequently installed electrical and electronic components comply with the EMC Directive 2014/30/EC in the relevant valid edition and bear the CE marking.
- In addition, the following requirements especially must be fulfilled for the subsequent installation of mobile communication systems (e.g. radio, telephone):
 - Only devices with approval according to the valid national regulations (e.g. BZT approval in the Federal Republic of Germany) may be installed.
 - The device must be installed permanently.
 - Operation of portable or mobile devices inside the vehicle is permitted only through a connection to a permanently installed outside antenna.
 - The transmitter must be installed in a separate location from the vehicle electronics.
 - When installing the antenna, pay attention to correct installation with good ground connection between antenna and vehicle ground.

1.6 Information about special risks

1.6.1 Exhaust gases



Danger

Inhaling exhaust gases is injurious to health and can lead to unconsciousness and to death! Never let the engine run in enclosed spaces. Danger to life due to toxic engine exhaust gases.

1.6.2 Re-fuelling the vehicle



Danger

Risk of fire! Diesel fuel is flammable! Take the utmost care when handling fuel. Never refuel close to naked flames or ignitable sparks. Do not smoke during fuelling. Switch off the engine, pull out the ignition key and engage the parking brake before fuelling.

1.6.3 Danger areas at the vehicle



Danger

- It is not permitted to stand underneath the dirt hopper if it is not secured. Always fit the safety strut whenever working underneath the dirt hopper. There is a danger to life!
- Special caution is required in the area of the front and rear-mounted equipment and attachments. There is a danger to life!
- Do not touch any parts such as engine block, cooling system and exhaust system during operation and for some time after. Allow the engine to cool down. There is a risk of burns from hot parts!
- Take the necessary precautions to ensure the vehicle is only used when in a safe and reliable condition. Only operate the vehicle if all protective and safety-oriented devices, such as removable safety devices, sound proofing elements and exhaust systems etc. are in place and fully functional.

1.6.4 Danger of tilting over



Danger

Danger of tilting over when driving uphill or downhill and transversely to a slope! Avoid sudden turns when driving uphill or downhill or across slopes. There is a risk of tilting over in an inclined position! The vehicle speed must always be adapted to the surrounding conditions and the load condition.

1.6.5 Suspended loads



Danger

Danger to life due to suspended loads! Do not stay or work under suspended loads!

1.6.6 Battery

**Danger**

- Danger of explosion due to smoking, fire or open light! Especially when being charged, but also in the normal use of batteries, batteries emit explosive gases! Avoid smoking, fire, sparks or open light in the vicinity of batteries!
- Danger of explosion due to sparks! Never place tools or other electrically conductive objects on the battery! Sparks that can ignite escaping gases arise if the poles are short-circuited. Always observe the correct order when connecting and disconnecting the battery!
 - Disconnecting the battery: First the minus pole and then the plus pole!
 - Connecting the battery: First the plus pole and then the minus pole!
- Danger of explosion due to frozen battery or too low acid level! With a frozen battery or if the acid level is too low, do not attempt to start with a jumper cable, the battery can burst or explode.
- Danger of burns due to battery acid! The special safety and accident prevention regulations must be complied with when handling the battery. Batteries contain sulphuric acid.

1.6.7 Noise

**Danger**

Risk of injury due to noise! Sound insulation devices on the vehicle must be in their protection position during operation. If required, wear hearing protectors!

1.6.8 Hydraulics

**Danger**

- Risk of injury! Hydraulic oil issuing under high pressure can penetrate the skin and cause severe injuries. Therefore, even with the smallest wounds, consult a doctor since otherwise severe infections can arise!
- Hydraulic pipes must be run and installed correctly! The work may be done only by authorised skilled persons. Make sure that no connections are mixed up! Fittings, length and quality, especially resistance to pressure and temperature of hydraulic pipes, must comply with the requirements.

1.6.9 Operating and auxiliary materials

**Danger**

- Risk of injury! Observe the safety regulations applicable for the product when handling oils, greases and other chemical substances (e.g. battery acid or sulphuric acid)!
- There is a risk of burns and scalds! Caution when handling hot operating and auxiliary materials.

1.7 Environmental protection instructions





Environmental danger

- Adequate knowledge is required for the safe handling of substances which could represent a risk to health and the environment.
- Observe the applicable laws and local regulations when disposing of detergents.
- During maintenance work and repairs, operating substances and filters have to be collected in suitable containers and properly disposed of observing the applicable laws and local regulations.
- Leaked oil, diesel fuel and lubricants etc. must not enter into the soil. Otherwise this would create a serious risk of groundwater contamination.
- Any contamination from leakages has to be cleared up without delay and disposed of properly. Used filters usually have to be disposed of as special waste (e.g. fuel filters) depending on the filtered substance.
- Ensure safe and environment-conserving disposal of operating and auxiliary materials. Take up escaping or spilled operating materials in suitable containers and dispose of them in an environmentally friendly manner.
- Used batteries with the recycling symbol contain reusable commodities. In accordance with the symbol showing the crossed-out garbage bin, these batteries must not be disposed of in the domestic waste. Return and recycling have to be arranged with the authorised Hako dealer as required in § 6 and § 8 of the German battery law (BattG)!

1.8 Shutting down and disposal

If the end of use of the vehicle or of its components is reached and this is handed over for scrapping, the components must be correctly disposed of. Here the regulations of the competent local authorities must be observed. The operating materials in the vehicle require special disposal and may not get into the environment. Further information about disposal is available through the competent local authorities and the authorised Hako dealer.

- Do not dispose of products with the symbol  at the end of their life in the domestic waste.
- Recycle used materials with the symbol  according to their labelling.
- Recycle packaging materials and do not throw them into the domestic waste.
- Recycle plastics that are identified with statement of the material, such as PPTV20 for example, and do not throw them into the domestic waste.
- Old batteries contain hazardous materials and must be returned to the distributor, disposed of correctly or delivered to a collecting point. Do not throw old batteries into the domestic waste.
- Treat operating materials such as oils, hydraulic fluids or fuels as hazardous waste and dispose of them correctly.
- Have refrigerants disposed of only by specialist firms with expert staff and the required technical equipment. Refrigerant may under no circumstances get into the atmosphere. Have refrigerants disposed of by an authorised workshop.
- Observe national regulations.

1.9 Labels on the vehicle

The following safety and instruction labels are affixed well legibly to the vehicle. Renew missing or illegible labels immediately.

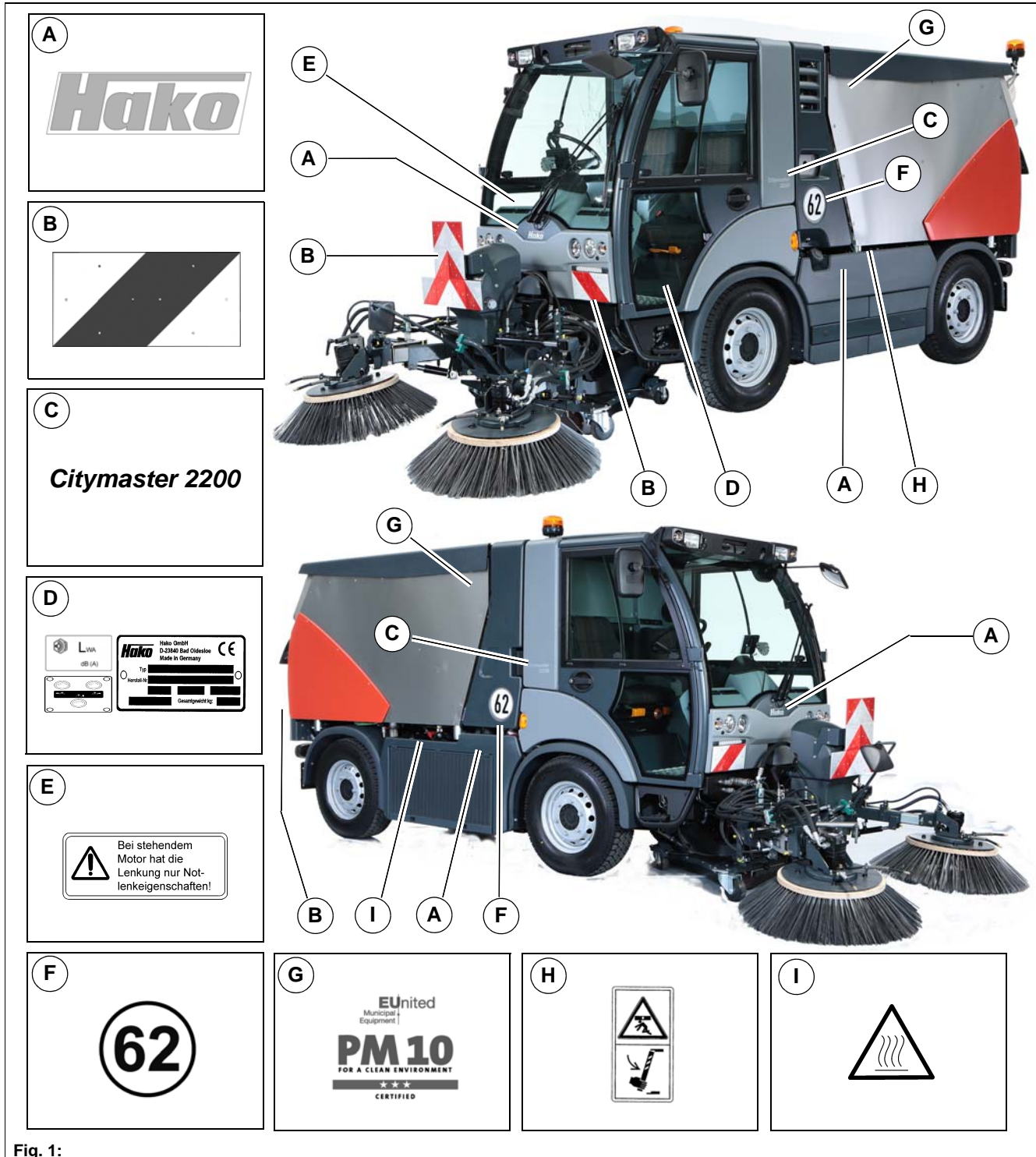

Fig. 1:

Hako company logo Fig. 1-A

The Hako company logo is located on the left and right cover and underneath the windscreen.

Warning signs Fig. 1-B

The warning signs are located on the vehicle cab, above the toolbox and on the sweeping unit.

Labels – Vehicle type Fig. 1-C

The Vehicle type labels are located on the left and right-hand side on the vehicle cab.

Label – Noise measurements and type plate Fig. 1-D

The Noise measurements label and the type plate are located in the vehicle cab under the driver's seat.

Label – Emergency steering Fig. 1-E

The Emergency steering label is located in the vehicle cab on the steering column.

Label – Allowed maximum speed Fig. 1-F

The Allowed maximum speed label is located on the left and right side cover.

Label – PM10 Fig. 1-G

The PM10 certificate label is located on the left and right side cover of the dirt hopper.

Label – Safety strut Fig. 1-H

The Safety strut label is located on the left and right frame of the dirt hopper.

Label – Hot surfaces Fig. 1-I

The Hot surfaces label is located on the cooling system of the engine.

2 Operation

2.1 Overviews

The description in chapter 2 contains information on the function and handling of the individual control displays on the vehicle.

The controls always have the same item number in all chapters.

“Option“ is used whenever controls or other components of the vehicle are installed as an option (requested by the customer).

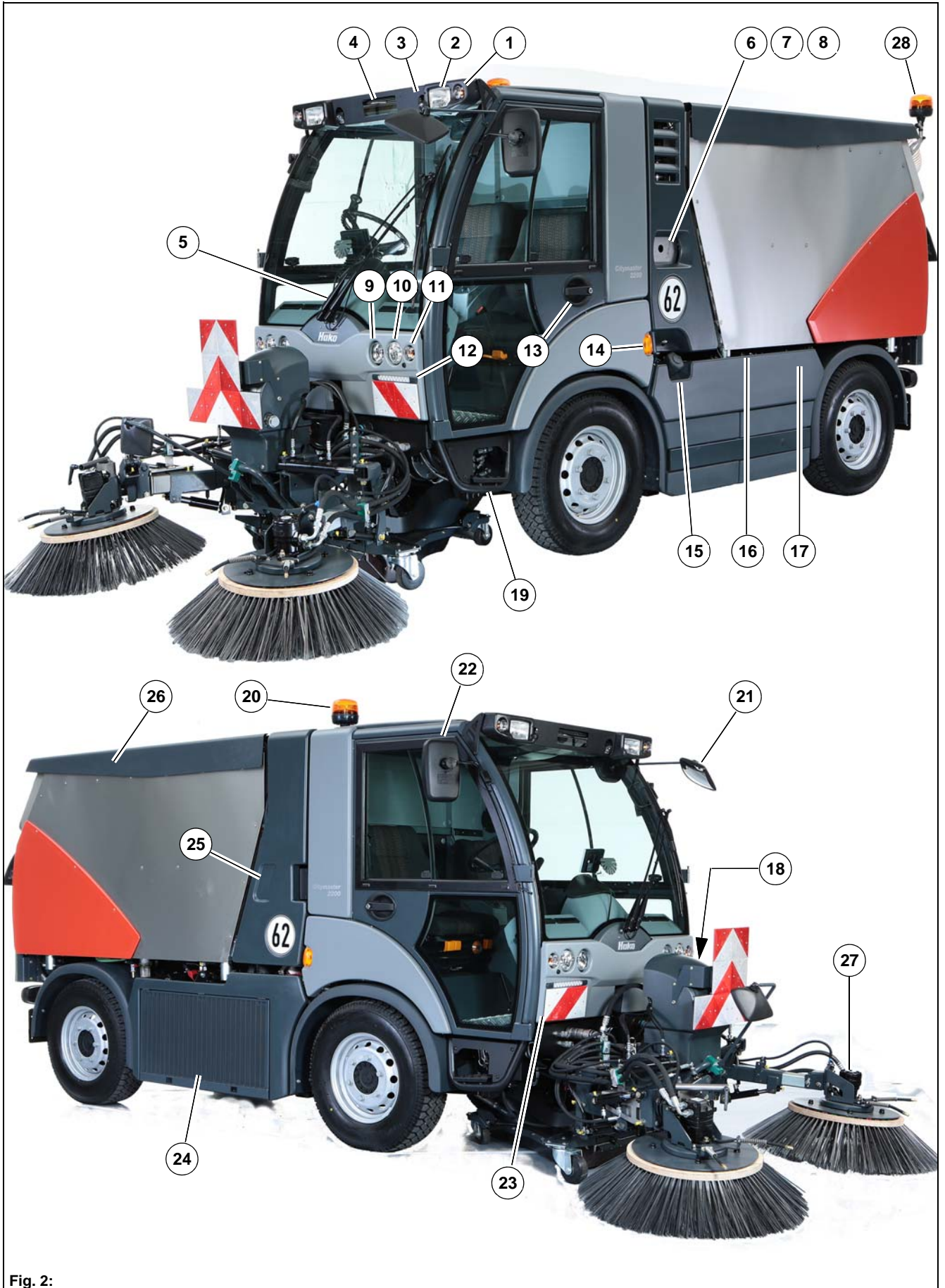

Fig. 2:

2.1.1 Front view

Item	Designation
1	Additional turn indicator (option)
2	Auxiliary headlights for low beam, high beam and parking light (option)
3	Working spotlight
4	Numberplate bracket (front)
5	Wiper
6	Jump-start socket (option)
7	Cooling system sight glass
8	Battery master switch (option)
9	Low beam headlights
10	Parking light headlights / High beam headlights
11	Turn indicator
12	Daytime running lights
13	Door handle / Door lock
14	Side indicator light
15	Fuel tank
16	Hydraulic oil tank
17	AdBlue tank
18	Front tool carrier for front-mounted equipment
19	Access
20	Rotating beacon
21	Kerbstone mirror
22	Rearview mirror
23	Warning signs
24	Cooling system
25	Tip switch for external control of the dirt hopper (option)
26	Dirt hopper
27	Sweeping unit (option)
28	Rotating beacon on dirt hopper (option)



Fig. 3:

2.1.2 Rear view

Item	Designation
29	Automatic lubrication system (option)
30	Exhaust gas system
31	AC condenser
32	Air filter
33	Engine compartment
34	Brake light, rear light, turn indicator, reversing light, rear fog light
35	Wheel chock
36	Numberplate bracket (rear)
37	Rear-mounted equipment carrier

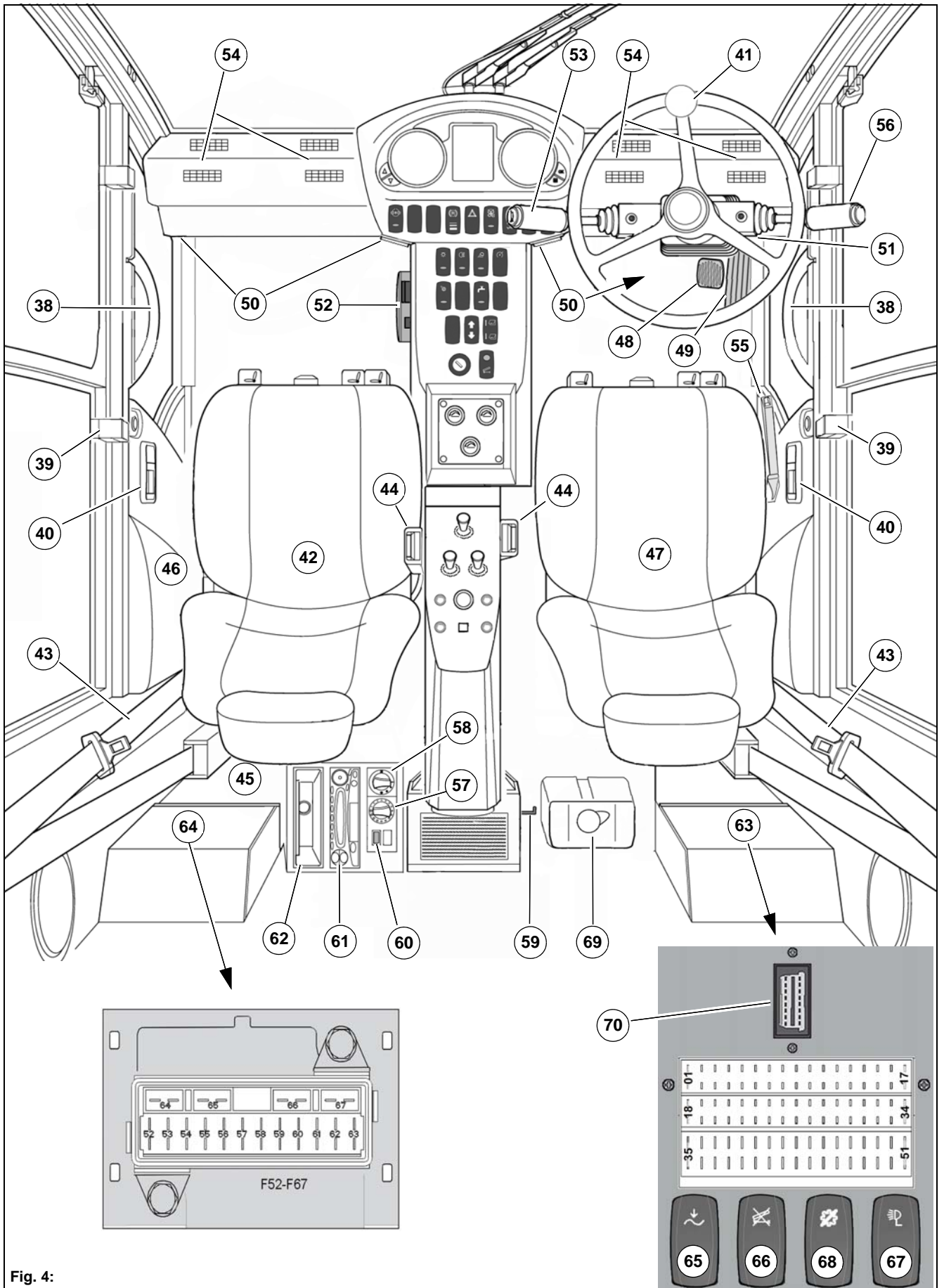

Fig. 4:

2.1.3 Vehicle cab

Item	Designation
38	Handle
39	Catches for sliding window
40	Door opener
41	Steering wheel for servohydraulic steering
42	Passenger seat
43	Three-point seat belt
44	Seat belt – lock
45	Storage compartment for toolbox, warning triangle and first-aid kit (behind passenger seat), control units
46	Storage compartment for operating manual (passenger seat rest)
47	Driver's seat
48	Brake pedal (service brake)
49	Accelerator pedal
50	Legroom air vent
51	Lever at the steering column for steering column adjustment
52	Cigarette lighter / 3-pin socket
53	Combined switch at the steering column (right) for windscreen wiper, windscreen washer unit, high beam / low beam, headlight flasher and horn, turn indicators
54	Windscreen air vent
55	Parking brake
56	Direction indicator switch (forwards/neutral/reverse)
57	Rotary switch (hot/cold)
58	Rotary switch – 3-stage suction fan
59	Air circulation lever
60	Air-conditioner switch
61	Installation area for radio / wireless device (option)
62	Storage compartment
63	Fuse box (right)
64	Fuse box (left)
65	Switch – pressure relief hydraulic connections (swivel 1)
66	Switch – tipper lock
67	Switch – auxiliary headlights ON/OFF (option)
68	Switch – recovery mode
69	Windscreen washer fluid tank
70	EOBD socket

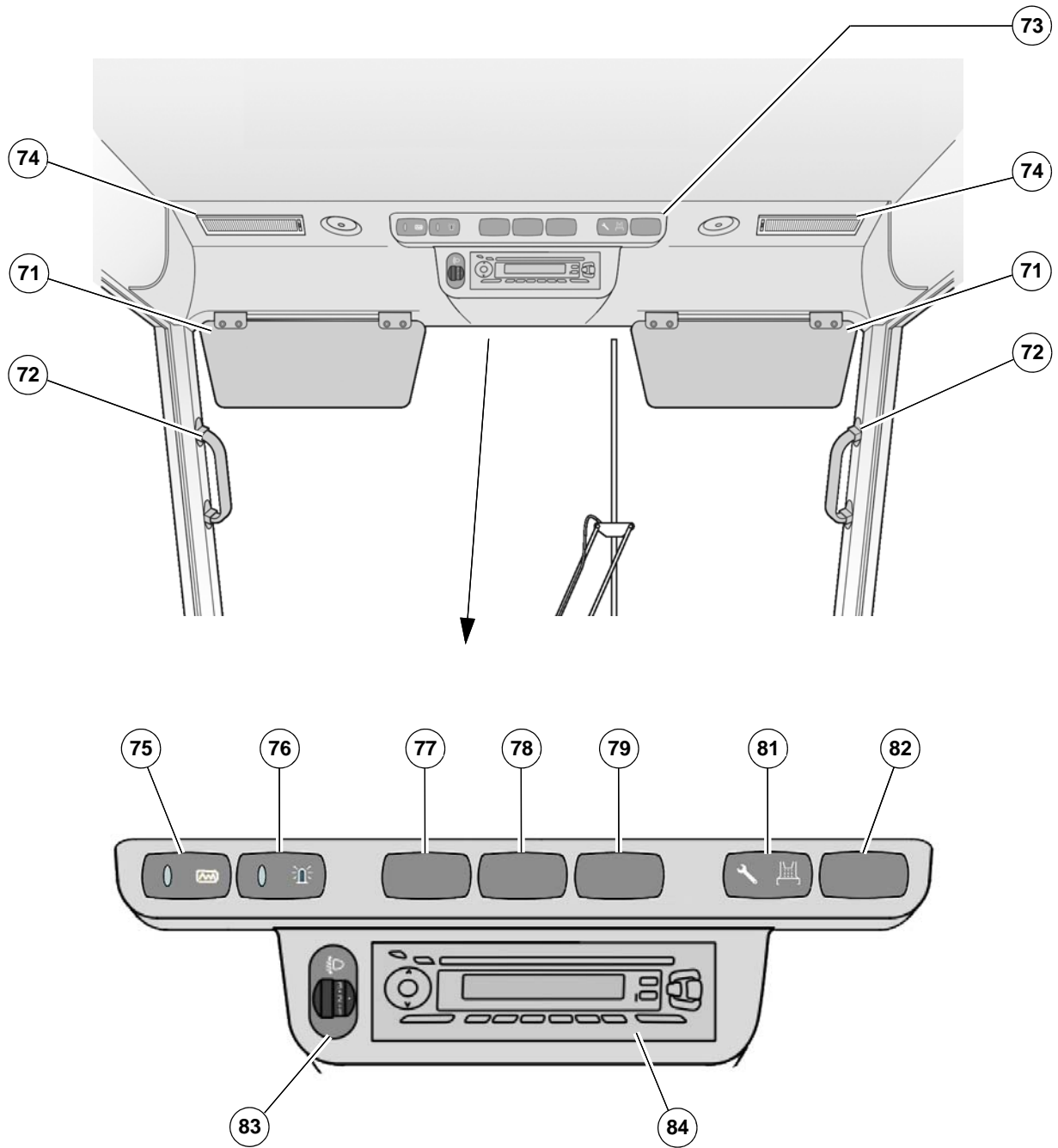

Fig. 5:

2.1.4 Roof console

Item	Designation
71	Sun visor
72	Handles
73	Roof console
74	Interior light
75	Tip switch – heated windscreen (option), heated outside rearview mirror (option)
76	Switch – rotating beacon
77	Not used
78	Not used
79	Not used
80	Free
81	Switch – circulating water service
82	Switch – external control, activate dirt hopper (option)
83	Headlight beam adjustment
84	EU control device (option) / radio (option)

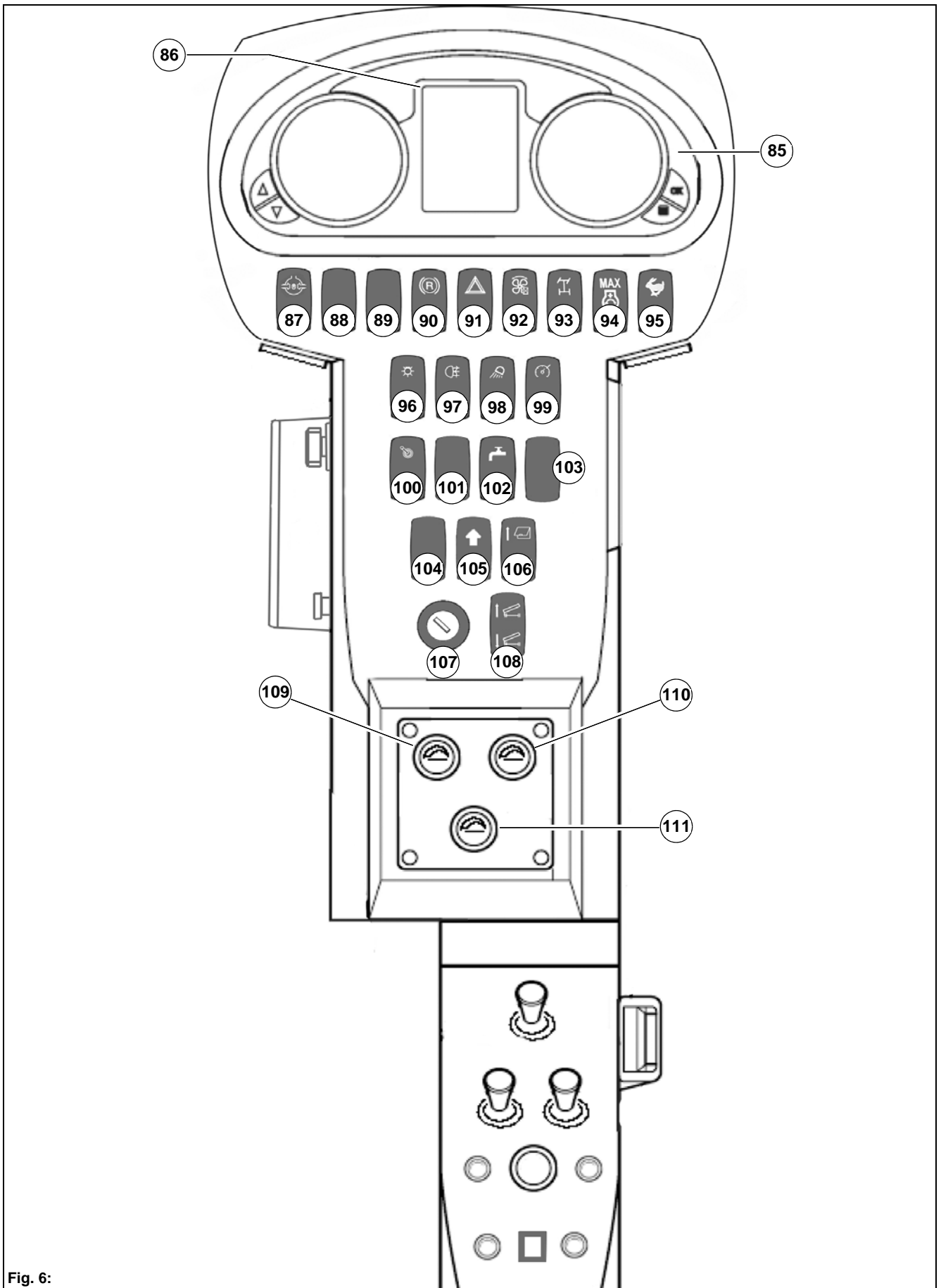

Fig. 6:

2.1.5 Centre console

Item	Designation
85	Indicating device
86	Multifunction display
87	Tip switch – differential lock (option)
88	Not used
89	Not used
90	Switch – hydrostatic brake force, stage 1, 2 and 3
91	Switch – hazard warning flasher ON/OFF (red)
92	Tip switch – reversing fan (option)
93	Tip switch – front wheel steering / four-wheel steering
94	Tip switch – engine speed ECO = 1400 rpm, standard = 1700 rpm, maximum = 2000 rpm
95	Tip switch – driving mode (transport mode / offset mode / work mode)
96	Switch – low beam with telltale
97	Tip switch – rear fog light with telltale
98	Tip switch – working lights with telltale
99	Tip switch – cruise control
100	Tip switch – rapid winter service (option)
101	Not used
102	Switch – 2nd fresh water pump (option)
103	Switch – reversing the direction of rotation for 3rd brush (option)
104	Switch – seat heating (option)
105	Tip switch – RAISE/LOWER front tool carrier
106	Tip switch – OPEN/CLOSE dirt hopper flap
107	Ignition switch
108	Tip switch – RAISE/LOWER dirt hopper
109	Valve – fresh water nozzle (with 2-brush system for the left brush) Valve – fresh water nozzle (with 3-brush system for the pulled brushes)
110	Valve – fresh water nozzle (with 2-brush system for the right brush) Valve – fresh water nozzle (with 3-brush system for the 3rd brush)
111	Valve – fresh water nozzle for the suction duct (option)

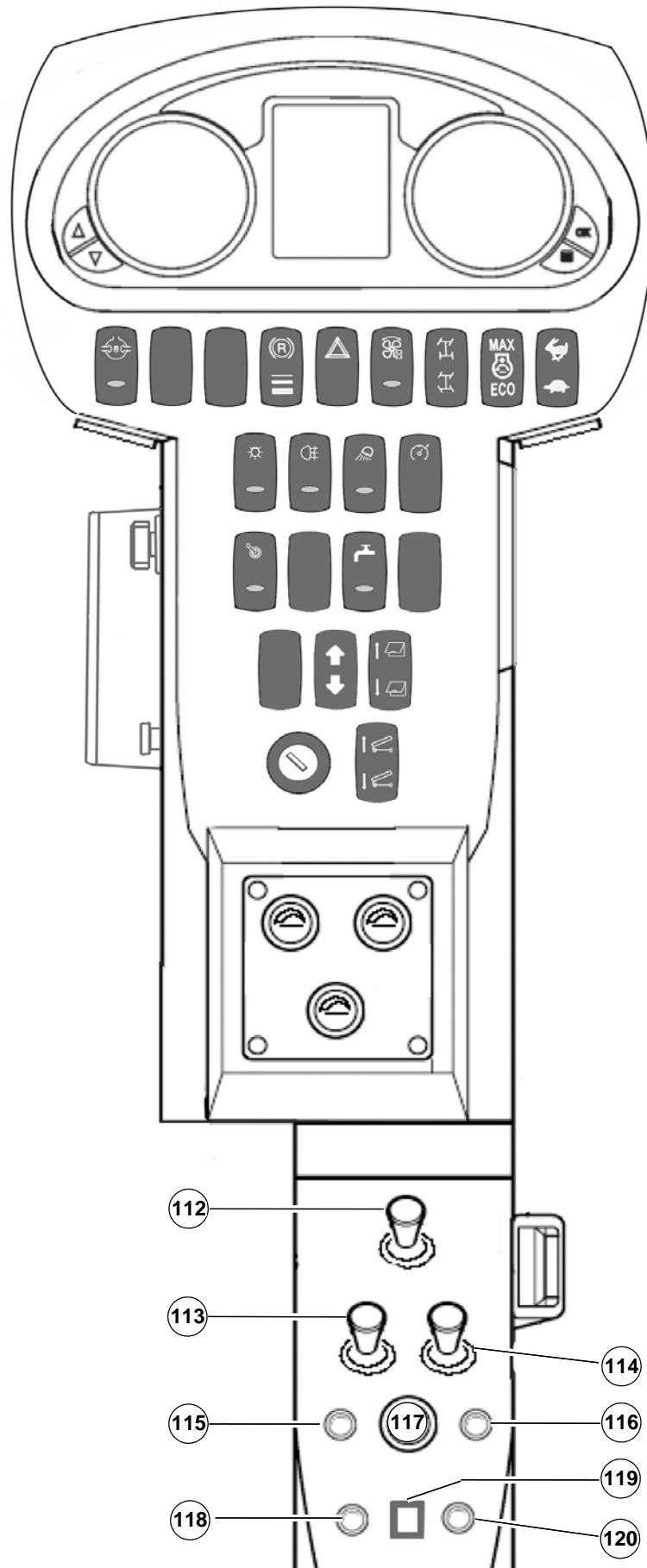

Fig. 7:

Centre console – continued

Item	Designation
112	TILT joystick (with 2-brush system only for the weed brush (option)) TILT joystick (with 3-brush system for the 3rd brush (option))
113	RAISE/LOWER/SWIVEL joystick (with 2-brush system for the left brush) RAISE/LOWER/SWIVEL joystick (with 3-brush system for the 3rd brush)
114	RAISE/LOWER/SWIVEL joystick (with 2-brush system for the right brush) RAISE/LOWER/SWIVEL joystick (with 3-brush system for the pulled brushes)
115	Quick select button for main consumers ON/OFF
116	Quick select button for main consumers ON/OFF
117	Turn-push knob
118	Tip switch – OPEN/CLOSE coarse material flap
119	Reversing tip switch
120	Tip switch – 1st fresh water pump ON/OFF

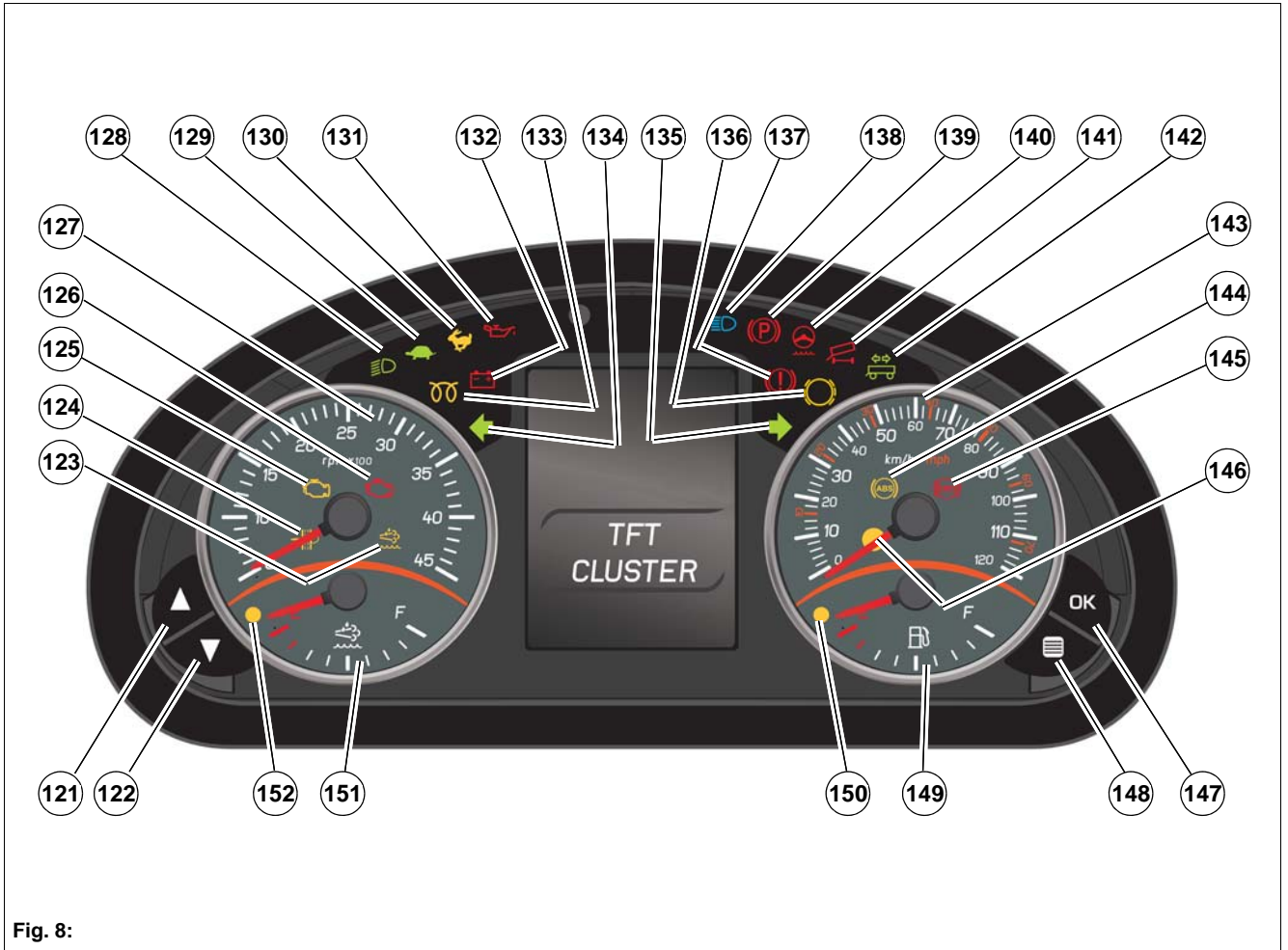

Fig. 8:

Centre console – continued

Item	Designation
121	Scroll UP button
122	Scroll DOWN button
123	Warning light – SCR
124	Telltale – diesel particle filter
125	Warning light – EOBD/MIL
126	Not used
127	Tachometer
128	Telltale – low beam
129	Telltale – work mode / offset mode
130	Telltale – transport mode
131	Warning light – engine oil pressure
132	Warning light – battery charging
133	Telltale – preheater
134	Telltale – turn indicator (left)
135	Telltale – turn indicator (right)
136	Warning light – brake lining wear
137	Warning light – brake
138	Telltale – high beam
139	Warning light – parking brake
140	Warning light – power steering oil level / hydraulic oil level
141	Telltale – tipper
142	Telltale – trailer turn indicator
143	Speedometer
144	Warning light – ABS
145	Warning light – EBD system
146	Not used
147	OK button
148	Menu button
149	Fuel level display
150	Warning light – fuel reserve
151	AdBlue level display
152	Warning light – AdBlue reserve

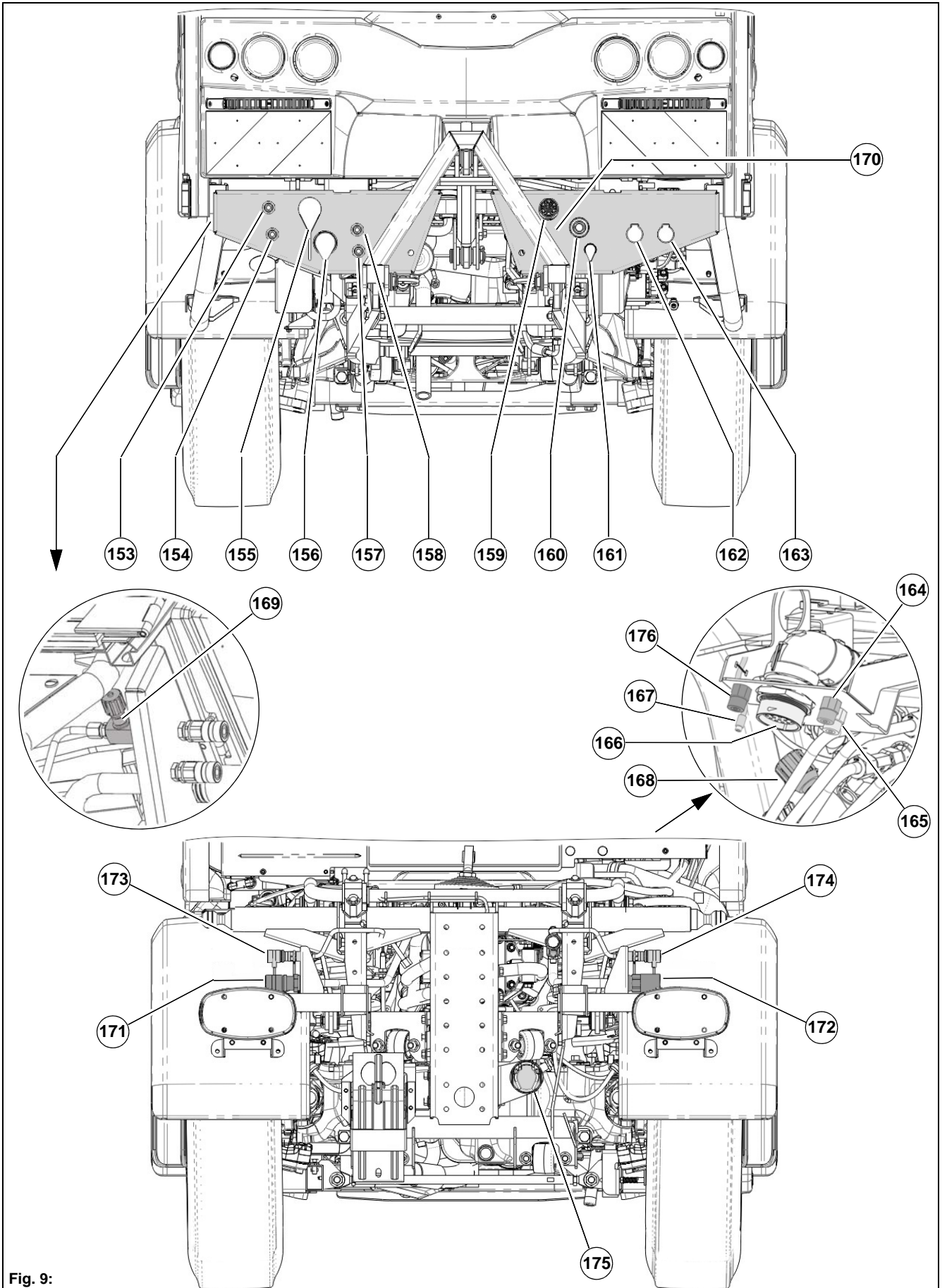

Fig. 9:

2.1.6 Hydraulic, water and electric connections

Item	Designation
	Front view
153	Connection for raising external lifting device, sleeve (red) (option)
154	Connection for lowering external lifting device, sleeve (red) (option)
155	Return of rotatory main consumer, sleeve (red)
156	Pressure connection for rotatory main consumer (front sweeping roller), sleeve (red) (option)
157	Water connection
158	Water connection
159	23-pin socket for coding plug, front-mounted equipment
160	Pressure connection for vacuum sweeping system control block, sleeve (blue)
161	LS connection for vacuum sweeping system control block, plug (blue)
162	Swivel to the right – swivel function for snow blade, sleeve (green) (option)
163	Swivel to the left – swivel function for snow blade, sleeve (green) (option)
164	Plug connection for 2nd fresh water pump (option)
165	Plug connection for 1st fresh water pump
166	23-pin socket for coding plug, front-mounted equipment
167	Socket for rear video camera (option)
168	Throttle valve for front tool carrier
169	Throttle valve for external lifting device (option)
170	Connection for suction mouth camera (option)
	Rear view
171	Pressure connection for suction fan, plug
172	Return for suction fan, sleeve
173	Swivel function – open dirt hopper flap, sleeve (green)
174	Swivel function – close dirt hopper flap, sleeve (green)
175	13-pin socket
176	Coupling for central lubrication system (option)

2.2 Overview of the most important controls

2.2.1 Battery master switch (option)

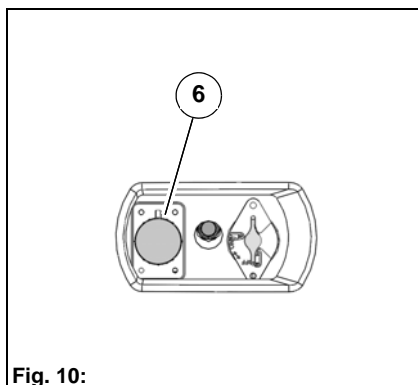

Fig. 10:

The battery master switch **Fig. 10-8** is located on the left-hand side of the vehicle behind the vehicle cab.

The battery master switch interrupts the power supply to all electric consumers in the vehicle, with the exception of the EU control device.

Interrupting the power supply

When the power supply is interrupted via the battery master switch, further supply of the engine control unit (afterrun) is ensured automatically. It is thus possible to operate the battery master switch immediately after switching off the ignition.

- Turn the key to the left (vertical) and remove.

Switching on the power supply

- Insert the key.
- Turn the key to the right until it locks into place (horizontally).

2.2.2 Jump-start socket (option)

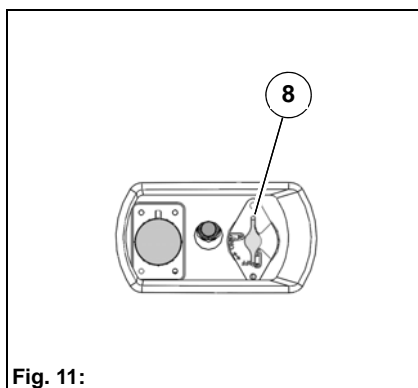

Fig. 11:

The vehicle is equipped with a jump-start socket **Fig. 11-6**. The socket is located on the left-hand side of the vehicle in the area of the vehicle battery. This socket can be used to jump start a vehicle using a jump lead, see chapter Maintenance.



Attention

Make sure the pole terminals on the jump lead are not reversed.

2.2.3 Ignition switch

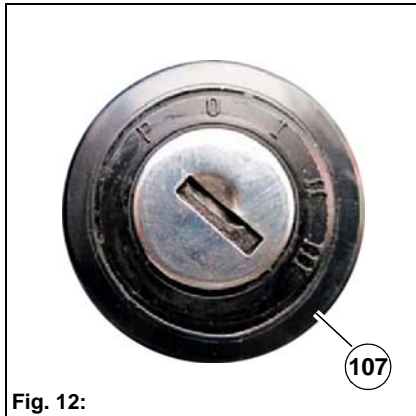



Fig. 12:

	<p>Note</p> <p>The engine can only be started when the battery master switch is switched on, the drive switch is in the neutral position and the accelerator pedal is not depressed.</p> <p>The ignition switch Fig. 12-107 is equipped with a start repeat lock to prevent the starter from engaging into the running diesel engine: Switch back to position 0 (Stop) before switching from position 1 to position 2 again.</p>
---	--

Position	Function	Power consumer
P/0	Ignition OFF / parking position Insert or remove the ignition key	<ul style="list-style-type: none"> The parking light, instrument lighting, cigarette lighter, interior lighting, rotating beacon and hazard warning flasher function even when the ignition key is removed. All telltales and warning lights are off
I	Ignition ON / Diesel engine OFF	<ul style="list-style-type: none"> All telltales and warning lights are on Warning light for the parking brake only lights up when the parking brake is applied.
	Ignition ON / Diesel engine ON	<ul style="list-style-type: none"> All telltales and warning lights must go out Warning light for the parking brake only lights up when the parking brake is applied.
	System check	<ul style="list-style-type: none"> Warning lights for engine oil pressure and battery charging light up. EOBD/MIL lamp flashes at defined intervals.
II	No function	
III	Start the engine	<ul style="list-style-type: none"> Starter is actuated. Telltales and warning lights must go out (except ABS; this can light up again for approx. 2.5 seconds).

2.2.4 Indicating device

Telltale and warning lights

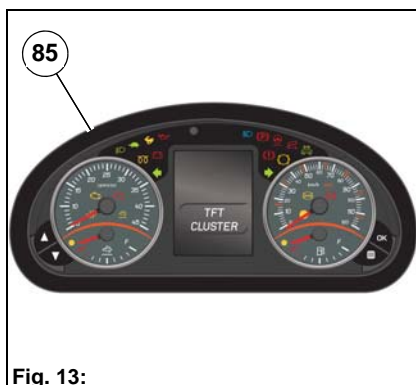

Fig. 13:







The indicating device is located in the centre console. The indicators of the indicating device enable a full overview of all the operating conditions.





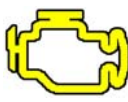

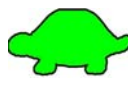











Attention

Not observing illuminated telltales and warning lights and/or warning messages and the associated descriptions and warnings can cause personal injury or damage to the vehicle!

Warning lights go out as soon as the malfunctions have been rectified. The following telltales and warning lights are integrated in the indicating device **Fig. 13-85**:

Item	Symbol	Col-our	Function
123		Yellow	SCR warning light The SCR and EOBD/MIL warning lights may light up at the same time and indicate whether malfunctions have occurred at the exhaust emission control system that have a direct influence on exhaust gas emissions. For more information, see page 191.
124		Yellow	Telltale – diesel particle filter If the diesel particle filter telltale lights up in the indicating device, the diesel particle filter has reached a critical load condition and must be regenerated. For more information, see page 191
125		Yellow	EOBD/MIL warning light (European On-Board Diagnosis) The SCR and EOBD/MIL warning lights may light up at the same time and indicate whether malfunctions have occurred at the exhaust emission control system that have a direct influence on exhaust gas emissions. For more information, see page 191.
126			Not used
128		Green	Telltale – low beam <ul style="list-style-type: none"> Lights up when the low beam is switched on.
129		Green	Telltale – work mode <ul style="list-style-type: none"> Lights up when the work mode / offset mode is switched on. Flashes when switching from transport mode to offset mode and until all the switch-over conditions have been fulfilled. If telltales 129 and 130 are flashing alternately, the vehicle is in emergency mode. The functional scope of the vehicle is limited considerably.
130		Green	Telltale – transport mode <ul style="list-style-type: none"> Lights up when transport mode is switched on. Flashes when switching from offset mode to transport mode, until all the switch-over conditions have been fulfilled. If telltales 129 and 130 are flashing alternately, the vehicle is in emergency mode. The functional scope of the vehicle is limited considerably.

131		Red	<p>Warning light – engine oil pressure</p> <ul style="list-style-type: none"> • Lights up when the ignition is switched on but goes out when the engine is started. • Lights up when the engine oil pressure is too low. <p>For more information, see page 186.</p>
132		Red	<p>Warning light – battery charging, alternator</p> <ul style="list-style-type: none"> • Lights up when the ignition is switched on but goes out when the engine is started. • Lights up while the engine is running in order to indicate that there is a defect in the alternator V-belt or in the charging circuit of the alternator. The battery is no longer being charged.
133		Yellow	<p>Telltale – preheater</p> <ul style="list-style-type: none"> • Lights up briefly when the key in the ignition switch is in pos. 1. • The preheating and afterglow phase of the diesel quick-start preheater is controlled depending on relevant parameters (temperatures) via the engine control system. • Once the lamp has gone out, the engine can be started.
134		Green	<p>Turn indicator (left)</p> <ul style="list-style-type: none"> • Flashes periodically when the turn indicator is actuated and the hazard warning flasher is switched on.
135		Green	<p>Right flasher</p> <ul style="list-style-type: none"> • Flashes periodically when the turn indicator is actuated and the hazard warning flasher is switched on.
136		Yellow	<p>Warning light – brake lining wear</p> <ul style="list-style-type: none"> • Lights up when the brake linings are worn. <p>For more information, see page 203.</p>
137		Red	<p>Warning light – brake</p> <p>Lights up when:</p> <ul style="list-style-type: none"> • the brake fluid level in the brake system tank is too low • the vacuum system of the power brake is malfunctioning; additionally, the maintenance symbol for the brake is shown in the multifunction display <p>For more information, see page 95.</p>
138		Blue	<p>Telltale – high beam</p> <ul style="list-style-type: none"> • Lights up when the high beam is switched on. • Lights up when the headlight flasher is switched on.
139		Red	<p>Warning light – parking brake</p> <ul style="list-style-type: none"> • Lights up when the parking brake is applied. • Flashes and buzzer sounds three times when driving with actuated parking brake.
140		Red	<p>Warning light – power steering oil level / hydraulic oil level</p> <ul style="list-style-type: none"> • Lights up when the hydraulic oil level is too low • Buzzer sounds three times. <p>Danger</p> <p>When the power steering oil level / hydraulic oil level warning light lights up, this may indicate a failure of the hydraulic power steering. However, it is still possible to steer the vehicle. Steering will then require much more force.</p> <p>There is a</p> <p>Risk of accidents</p> <ul style="list-style-type: none"> • Reduce the vehicle speed immediately. • Drive slowly to an authorised workshop. • Rectify (or have rectified) the cause of the oil loss. • Check the hydraulic oil level in the tank and correct if required.

141		Red	<p>Warning light – tipper</p> <ul style="list-style-type: none"> • Lights up when the tipper is raised. • Buzzer sounds once.
142		Green	<p>Telltale – trailer turn indicator</p> <ul style="list-style-type: none"> • Flashes periodically when the turn indicator is actuated and the hazard warning flasher is switched on and there is an electric connection to the trailer.
144		Yellow	<p>Warning light – ABS (anti-blocking system)</p> <ul style="list-style-type: none"> • Lights up when the ignition is switched on for approx. 3 seconds and goes out if no current faults are detected in the ABS. • Lights up in case of special operating conditions. In this case, the symbol "brake special mode" is shown in the multifunction display, the ABS is not available (wheels may block), EBD is active. • Lights up when there is an error in the ABS. ABS is not available (wheels may block). If the EBD light does not light up, the EBD is still active. Seek assistance from an authorised workshop for troubleshooting. Drive carefully in this situation. <p>When the warning light lights up, driving speed is limited to 25 km/h.</p>
145		Red	<p>Warning light – EBD (electronic brake-force distribution system)</p> <ul style="list-style-type: none"> • Lights up when the ignition is switched on for approx. 3 seconds and goes out if no serious fault is detected in the ABS. • Lights up if a serious fault is detected in the ABS. ABS and EBD are no longer available (wheels may block, the legally stipulated blocking sequence is no longer observed). The ABS lamp also lights up. Immediately seek assistance from an authorised workshop for troubleshooting. Drive carefully in this situation. <p>When the warning light lights up, driving speed is limited to 25 km/h.</p>
146		Yellow	<p>Warning light – fuel reserve</p> <ul style="list-style-type: none"> • Buzzer sounds once. • Lights up when the residual content reaches 11.5 litres.
152		Yellow	<p>Warning light – AdBlue reserve</p> <ul style="list-style-type: none"> • Buzzer sounds once. • Lights up when the residual content reaches 6.5 litres. <p>The driver warning and request system (SCR warning light) has not yet been activated.</p>

Speedometer



Fig. 14:

The speedometer **Fig. 14-143** indicates the current driving speed in km/h (kilometres per hour) and mph (miles per hour).



Note

The vehicle has been set at the factory to the tyre size fitted on the vehicle at delivery. If the vehicle is fitted with a different approved tyre size, this must be set accordingly by an authorised workshop.

Fuel gauge



Fig. 15:

The fuel gauge **Fig. 15-149** shows the fuel reserve.

If the warning light lights up in the indicating device **Fig. 15-150**, there are approx. 11.5 litres of diesel left in the tank, see page 190.



Attention

Do not start the vehicle when the fuel tank is empty. This can lead to engine damage.

- Never let the fuel tank run dry.
- Always refuel the vehicle in good time.
- Inform an authorised workshop.

Tachometer



Fig. 16:

The tachometer **Fig. 16-127** displays the speed of the diesel engine (in rpm x 100 = revolutions per minute x 100).

AdBlue display



Fig. 17:

The AdBlue display **Fig. 17-151** shows the tank level. As soon as the pointer reaches the red zone, the warning light **Fig. 17-152** lights up. If the warning light lights up in the indicating device **Fig. 17-152**, there are approx. 6.5 litres of diesel left in the tank, see page 191.

2.2.5 Multifunction display

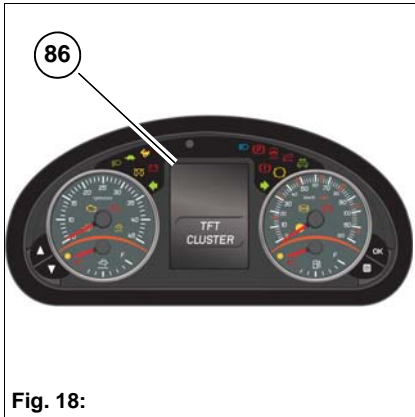

Fig. 18:

The multifunction display **Fig. 18-86** monitors a variety of vehicle functions and operating parameters. The multifunction display also provides information on the vehicle status and on maintenance and malfunctions.

	<p>Attention</p>
<p>Not observing warning messages and the associated descriptions and warnings can cause damage to the vehicle.</p>	
	<p>Note</p>
<p>The warning messages will disappear when the associated malfunction has been rectified.</p>	

Menu guidance

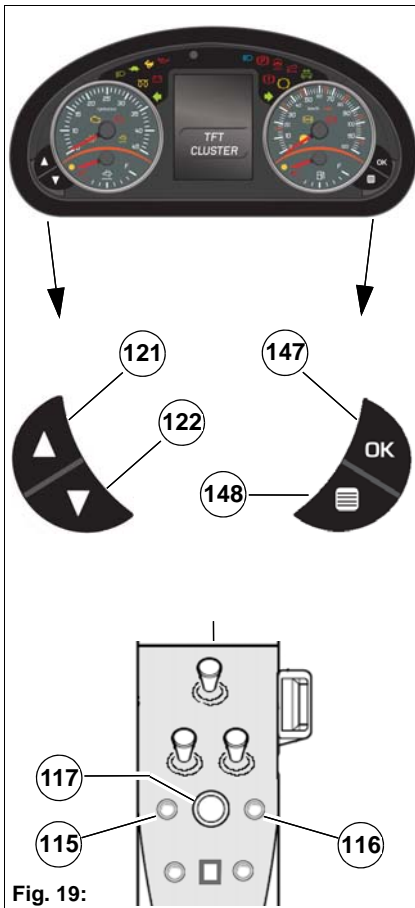

Fig. 19:

The multifunction display contains two separate menu structures. The settings of the indicating device are executed with one menu branch and the settings of the work hydraulics with the other.

The menu guidance in the indicating device is carried out using the following controls:

- Use the SCROLL UP button **Fig. 19-121** to move the cursor up in the menu.
- Use the SCROLL DOWN button **Fig. 19-122** to move the cursor down in the menu.
- Use the OK button **Fig. 19-147** to activate a menu item.
- Use the Menu button **Fig. 19-148** to open the reset menu or the options menu.

The menu guidance for the work hydraulics is carried out using the following controls:

- Use the quick select buttons **Fig. 19-115** and **Fig. 19-116** and the turn-push knob **Fig. 19-117** to control the menus for setting the work hydraulics, see page 66.

**Normal display –
drive operation**

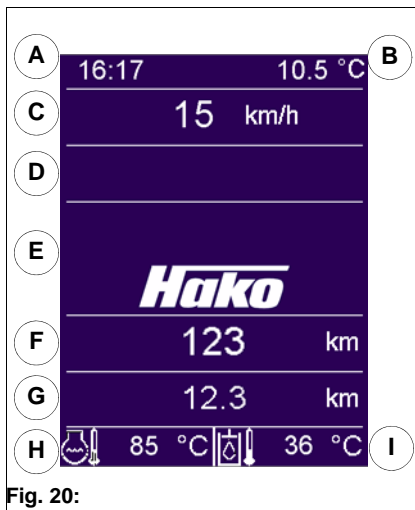

	Display section	Remark
A	Time	The time is displayed in h:min. The time can be set via the options menu.
B	Outside temperature	The outside temperature is displayed in °C -40 °C to +65 °C (+/- 0.5 °C) A snowflake symbol indicates a temperature below +4 °C.
C	Operating data	Display of fuel consumption or operating hours.
D	Drive messages	Display of messages.
E	Warning messages	If no messages are available: Hako logo
F	Total mileage	Display of the total mileage in km or miles. Units can be set via the options menu.
G	Trip	Display of the trip in km or miles. Units can be set via the options menu.
H	Temperature Coolant	The temperature of the coolant is displayed in °C.
I	Temperature Hydraulic oil	The temperature of the hydraulic oil is displayed in °C.

Normal display – working operation

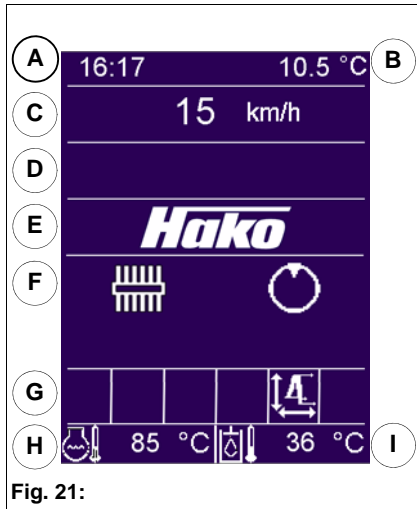

	Display section	Remark
A	Time	The time is displayed in h:min. The time can be set via the options menu.
B	Outside temperature	The outside temperature is displayed in °C -40 °C to +65 °C (+/- 0.5 °C) A snowflake symbol indicates a temperature below +4 °C.
C	Operating data	Display of fuel consumption or operating hours.
D	Drive messages	Display of messages.
E	Warning messages	If no messages are available: Hako logo
F	Attachments	Indicates whether attachments are switched on or off.
G	Additional functions	Display of available additional functions.
H	Temperature Coolant	The temperature of the coolant is displayed in °C.
I	Temperature Hydraulic oil	The temperature of the hydraulic oil is displayed in °C.

**Display section –
operating data**

Various operating parameters can be displayed in the operating data display section **Fig. 22-C**. For changing the displayed operating parameter, press the SCROLL UP button **Fig. 22-121** or the SCROLL DOWN button **Fig. 22-122**.

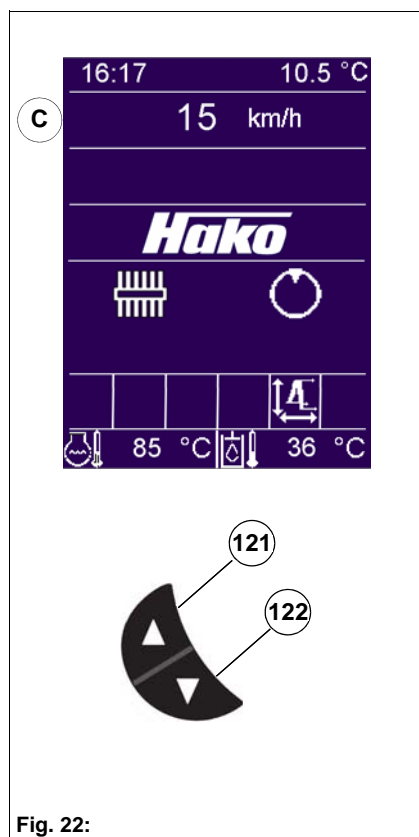









Fig. 22:

	Display section	Remark
C	Fuel consumption (current consumption)	Display of the current fuel consumption in l/h. When the speed is higher than 10 km/h, the current fuel consumption is automatically displayed in l/100 km or mi/l.
	Fuel consumption (average fuel consumption)	Display of the average fuel consumption in l/100 km or mi/l.
	Fuel consumption (average consumption)	Display of the average fuel consumption in l/h.
	Diesel engine hour meter	Display of the diesel engine operating hours in h. Counting starts as soon as the diesel engine is started. Is permanently saved, cannot be reset.
	Work hydraulics hour meter	Display of the work hydraulic operating hours in h. Counting starts when the work hydraulics is switched on. Is permanently saved, cannot be reset.
	Speed	Display of the current vehicle speed as a digital value in km/h or mph.
	Sweeping kilometres	Display of the distance travelled in work mode
	Sweeping operating hours	Display of the operating hours in work mode













Display section – drive messages





The following symbols may be displayed in the drive messages display section **Fig. 21-D**.

Symbol	Colour	Message	Meaning
	White	Hydrostatic brake force	Hydrostatic brake force stage I is switched on.
	Green	Hydrostatic brake force	Hydrostatic brake force stage II is switched on.
	Yellow	Hydrostatic brake force	Hydrostatic brake force stage III is switched on.
	Yellow	Recovery mode	Recovery mode is switched on.
	Green	Front wheel steering	Symbol flashes until the rear axle is in the straight-ahead position. Front wheel steering is switched on automatically and the symbol lights up.
	Green	Four-wheel steering	Symbol flashes until the front axle is in the straight-ahead position. Four-wheel steering is switched on automatically and the symbol lights up.
	Green	Driving speed control	Driving speed control is switched on.

Display section – warning messages

The following symbols may be displayed in the warning messages display section **Fig. 21-E**.

Symbol	Colour	Buzzer	Message	Meaning
	Green	Once	Seat contact switch	Lights up when the drive switch or the accelerator pedal are actuated and: <ul style="list-style-type: none"> the body weight has not been set correctly at the driver's seat. the driver's seat is not loaded.
	Green	Once	Direction indicator switch Neutral position	Lights up when the direction indicator switch is not in the neutral position.
	Yellow	Twice	Pressure filter	Lights up when the pressure filter of the drive pump is soiled. <ul style="list-style-type: none"> Seek assistance from an authorised workshop.
	Green	Once	Brake special mode	Lights up when the four-wheel steering or the differential lock (option) is switched on. ABS is not available.
	Yellow	Twice	Brake maintenance	Lights up if a fault is detected in the brake system. <ul style="list-style-type: none"> Seek assistance from an authorised workshop soon. If the ABS symbol in the indicating device also lights up: <ul style="list-style-type: none"> Seek assistance from an authorised workshop immediately.
	Red	Three times	Dirt hopper flap	Lights up when the dirt hopper flap is open. <ul style="list-style-type: none"> Close the dirt hopper flap.
	Red	Three times	Wheel load (option)	Lights up when the permissible axle load is exceeded.
	Yellow	Twice	Central lubrication overpressure (option)	Lights up when the central lubrication is soiled.
	Yellow	Twice	Central lubrication level (option)	Lights up when the level of the central lubrication is too low.
	Yellow	Twice	Return filter Hydraulic oil	Lights up when the return filter in the tank is soiled. <ul style="list-style-type: none"> Seek assistance from an authorised workshop.
	Red	Three times	Coolant level	Lights up when the coolant level is too low. <ul style="list-style-type: none"> Top up coolant. Check the cause. Seek assistance from an authorised workshop.
	Yellow	Twice	Air filter contamination	Lights up when the safety cartridge is soiled. <ul style="list-style-type: none"> Replace the safety cartridge.
	Yellow	Twice	Water in the fuel filter	Lights up when there is water in the fuel filter. Lights up when the fuel filter is soiled. <ul style="list-style-type: none"> Seek assistance from an authorised workshop.

	Red	Three times	Error message EU control device	There is an error in the EU control device.
	Green	Once	Note	Message regarding an uncritical vehicle condition. Follow the instruction / rectify. <ul style="list-style-type: none"> • If necessary, seek assistance from an authorised workshop.
	Yellow	Twice	Warning	Message regarding a critical vehicle condition. <ul style="list-style-type: none"> • Check the cause. • Seek assistance from an authorised workshop.
	Red	Three times	Error message	Message regarding a very critical vehicle condition. <ul style="list-style-type: none"> • Stop the vehicle • Seek assistance from an authorised workshop.
	Yellow	Twice	Warning	Seek assistance from an authorised workshop.

Display section – additional functions

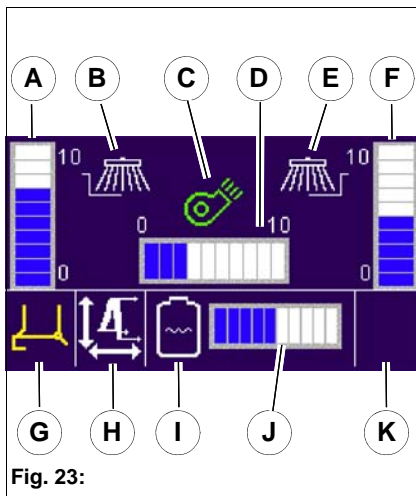

Fig. 23:

Summer service

Display section	More information
A	Bar chart – left-hand brush drive Displays the set volume flow of the left-hand brush drive.
B	Symbol – left-hand brush see page 64
C	Symbol – suction fan see page 64
D	Bar chart – suction fan Displays the current speed of the suction fan.
E	Symbol – right-hand brush see page 64
F	Bar chart – right-hand brush drive Displays the set volume flow of the right-hand brush drive.
G	Symbol – coarse material flap see page 64
H	Symbol – area clearing function see page 64
I	Symbol – fresh water see page 64
J	Bar chart – fresh water Displays the current level in the fresh water tank.
K	Symbol – low supply see page 64

Winter service

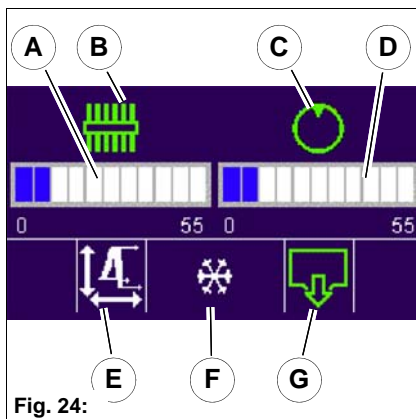



























Fig. 24:

Display section	More information
A	Bar chart – front-mounted equipment Shows the set volume flow.
B	Symbol – front-mounted equipment see page 65
C	Symbol – attachment see page 65
D	Bar chart – attachment Shows the set volume flow.
E	Symbol – area clearing function see page 65
F	Symbol – snowflake see page 65
G	Symbol – quick emptying see page 65

Summer service symbols

	Symbol	Colour	Meaning
B		White	<ul style="list-style-type: none"> • Left-hand brush deactivated
B		Green	<ul style="list-style-type: none"> • Left-hand brush activated
C		White	<ul style="list-style-type: none"> • Suction fan deactivated
C		Green	<ul style="list-style-type: none"> • Suction fan activated
E		White	<ul style="list-style-type: none"> • Right-hand brush deactivated
E		Green	<ul style="list-style-type: none"> • Right-hand brush activated
G		Yellow	<ul style="list-style-type: none"> • Coarse material flap open
H		White	<ul style="list-style-type: none"> • Area clearing function available and deactivated
H		Green	<ul style="list-style-type: none"> • Area clearing function available and activated
I		White	<ul style="list-style-type: none"> • Fresh water pump deactivated
I		Green	<ul style="list-style-type: none"> • Fresh water pump activated • Level sufficient
I		Red	<ul style="list-style-type: none"> • Fresh water pump activated • Level too low
K		Yellow	<ul style="list-style-type: none"> • Low supply of the hydraulic pump (insufficient speed for volume flow)

Winter service symbols

	Symbol	Colour	Meaning
B		White	<ul style="list-style-type: none"> • Front-mounted equipment switched off and front-mounted equipment automatic system deactivated
B		Green	<ul style="list-style-type: none"> • Front-mounted equipment switched on and front-mounted equipment automatic system deactivated
B		White	<ul style="list-style-type: none"> • Front-mounted equipment switched off and front-mounted equipment automatic system activated
B		Green	<ul style="list-style-type: none"> • Front-mounted equipment switched on and front-mounted equipment automatic system activated
C		White	<ul style="list-style-type: none"> • Attachment switched off, quick emptying activated
C		Green	<ul style="list-style-type: none"> • Attachment switched on, quick emptying activated
C		White	<ul style="list-style-type: none"> • Attachment switched off, distance-dependent spreading activated
C		Green	<ul style="list-style-type: none"> • Attachment switched on, distance-dependent spreading activated
E		White	<ul style="list-style-type: none"> • Area clearing function available and deactivated
E		Green	<ul style="list-style-type: none"> • Area clearing function available and activated
F		White	<ul style="list-style-type: none"> • Winter service activated
G		Green	<ul style="list-style-type: none"> • Quick emptying activated

Adjustment menu

Summer service

By connecting the attachment to the 23-pin socket it is differentiated between summer and winter service and the respective functions are automatically released in the control unit. The sweeping functions are set in the adjustment menu for summer service. The current function to be adjusted is presented as a symbol. If the symbol is white, the function is switched off. If the symbol is green, the function is switched on.

Setting the suction fan speed

- Briefly pressing the turn-push knob **Fig. 25-117** opens the adjustment menu **Fig. 25-A** for the suction fan speed.
- Rotating the turn-push knob **Fig. 25-117** changes the value in the bar charts **Fig. 25-F**. The bar chart is divided into 10 increments.

Setting the brush speed / brush pressure

- Briefly pressing the quick select buttons **Fig. 25-115** or **Fig. 25-116** switches on/off the main consumer **Fig. 25-B, C, D or E** and opens the adjustment menu of the respective main consumer.
- Rotating the turn-push knob **Fig. 25-117** changes the value in the bar charts **Fig. 25-F**. The bar chart is divided into 10 increments.
- Briefly pressing the turn-push knob **Fig. 25-117** displays the next function.
- The adjustment menu can be closed by pressing the turn-push knob for longer and closes automatically after 5s without input.
- If only the turn-push knob is rotated in the normal display, the last adjusted function opens.

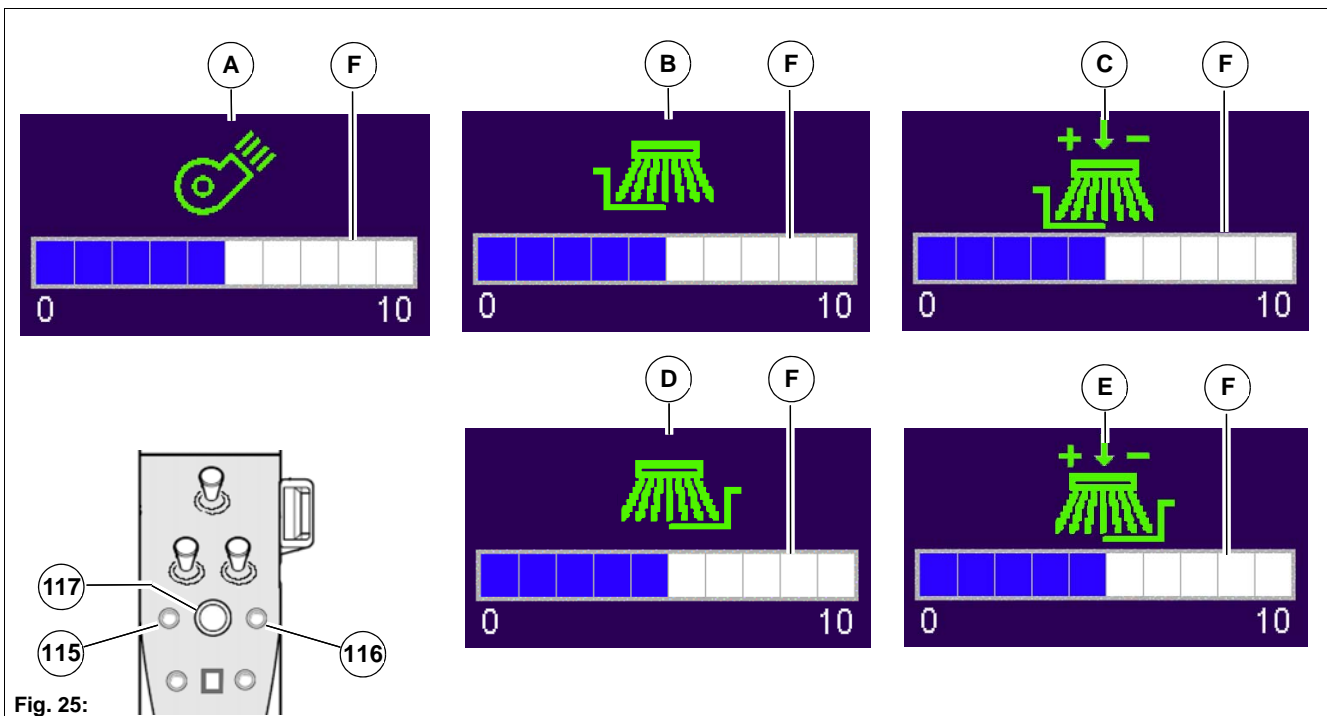

Winter service

By connecting the attachment to the 23-pin socket it is differentiated between summer and winter service and the respective functions are automatically released in the control unit. The volume flows for the main consumers are set in the adjustment menu for winter service. The current function to be adjusted is presented as a symbol. If the symbol is white, the function is switched off. If the symbol is green, the function is switched on. The functions front-mounted equipment **Fig. 26-A** or attachment **Fig. 26-B** can be set.

Setting the main consumer

- Briefly pressing the quick select buttons **Fig. 26-115** or **Fig. 26-116** switches on/off the main consumer **Fig. 26-A** or **B** and opens the adjustment menu of the respective main consumer.
- Rotating the turn-push knob **Fig. 26-117** changes the value of the bar chart. One bar corresponds to 5 l/min and is divided into 4 increments (1.25 l/min). The maximum position corresponds to 55 l/min.
- Pressing the quick select buttons for longer (>1 s) opens only the adjustment menu without changing the activation status of the main consumer.
- The adjustment menu can be closed by pressing the turn-push knob for longer and closes automatically after 5 s without input.



Note

Initial brief actuation of the tip switches **Fig. 25-115** or **Fig. 25-116** after starting the vehicle does not directly activate the main consumers, but only opens the adjustment menu so that the driver can check the volume flow before activating the main consumer.

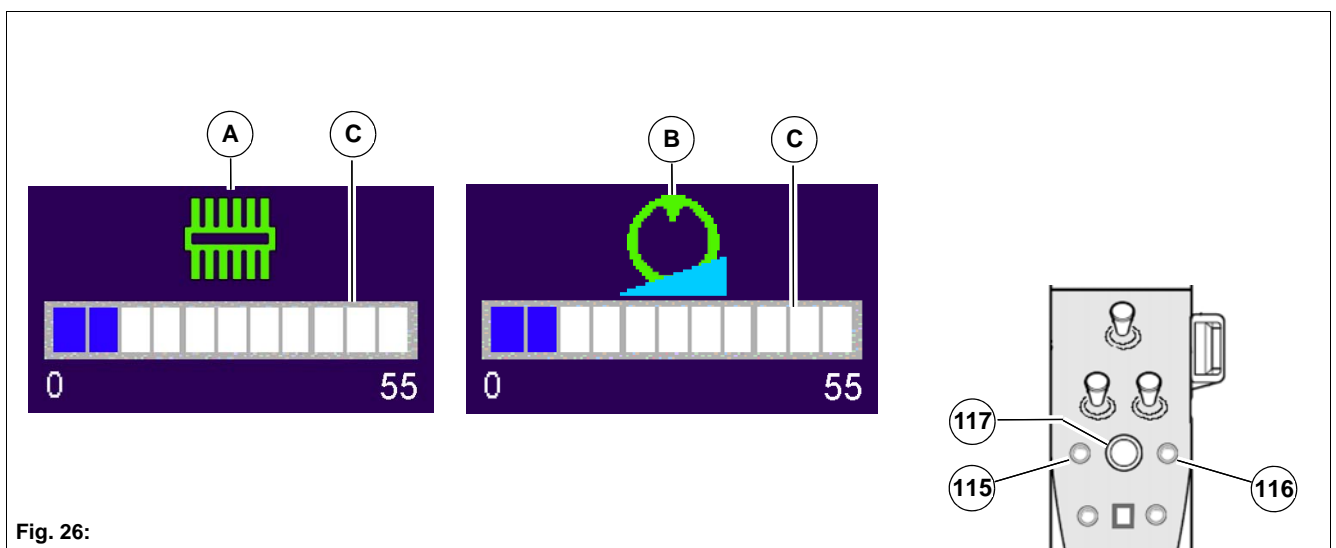

Fig. 26:

Selection menu (additional functions)

The available additional functions are activated and deactivated in the selection menu **Fig. 27-A**.

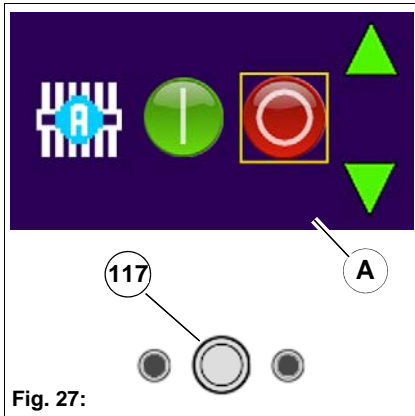





Fig. 27:

Symbol	Colour	Meaning
	Red	Deactivate
	Green	Activate



Selecting additional functions

- In work mode, press the turn-push knob **Fig. 27-117** for more than 2 seconds. The selection menu appears.
- The additional function is activated or deactivated by pressing the turn-push knob. The yellow frame around one of the symbols listed in the following table shows the current activation status.
- It is possible to toggle between the additional functions by rotating the turn-push knob. The arrows indicate that further additional functions are available.

The following additional functions are possible in summer service:

Symbol	Colour	Additional function	Meaning
	White	Suction mouth lift system when reversing	When engaging reverse gear, the front-mounted equipment is raised automatically. When changing to a forward gear, it is lowered again.

The following additional functions are possible in winter service:

Symbol	Colour	Additional function	Meaning
	White	Front-mounted equipment automatic system	When the main consumer is activated, the main consumer is switched off automatically when raising the equipment. When lowering the device again, the main consumer is switched on automatically.
	White	Area clearing function	When engaging reverse gear, the front-mounted equipment is raised automatically. When changing to a forward gear, it is lowered again.
	White	Quick emptying	A quick emptying option is available when changing the spreading material or cleaning the attachment.

Display of the coolant temperature

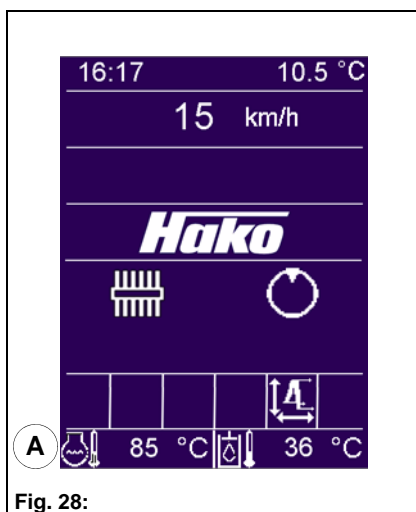

Fig. 28:

The temperature indicator **Fig. 28-A** indicates the temperature of the engine coolant in °C. The font colour of the symbol changes depending on the temperature. During operation, the symbol should light up green, i.e. the coolant temperature is in the optimum operating range.

Colour	Message	Remark
White	Temperature low	<70 °C
Green	Temperature in operating range	70 °C to 108 °C
Red	Temperature over-high <ul style="list-style-type: none"> Allow the engine to cool down. Clean the radiator. Rectify (or have rectified) the cause of the increased coolant temperature. Check the coolant level and top up if necessary. 	>108 °C If the temperature exceeds 112 °C , a signal tone is output three times, and a warning symbol is displayed full-screen for five seconds in the multifunction display.



Danger

Never open the coolant tank or drain coolant when the engine is warm, as the cooling system will be under high pressure. There is a risk of scalding!

- Wait at least 10 minutes after switching off the engine.
- Wear protective gloves and clothing.
- Always start by actuating the safety valve in the expansion tank filler cap; to do this, open the filler cap to the first notch and allow the pressure to escape.



Note

To cool the engine down faster:

- Stop the vehicle and switch off the working equipment.
- Run the engine with increased idle speed until the coolant temperature has returned to the normal range.

Display of the hydraulic oil temperature

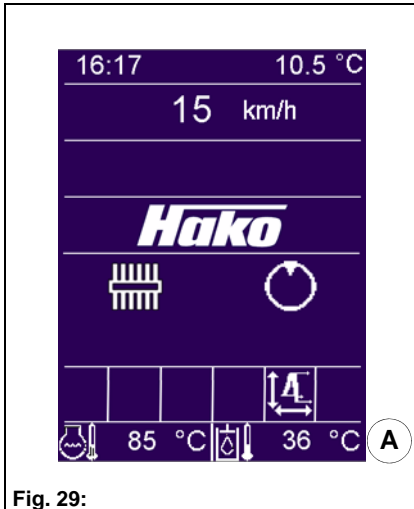

Fig. 29:

The temperature indicator **Fig. 29-A** indicates the temperature of the hydraulic oil in °C. The font colour of the symbol changes depending on the temperature. During operation under load, the symbol should light up green, i.e. the oil temperature is in the optimum operating range.

Colour	Message	Remark
White	Temperature low	<30 °C
Green	Temperature in operating range	30 °C to 75 °C
Red	Temperature over-high	>75 °C The interlocking circuit for the work hydraulics intervenes.

Interlocking circuit for the work hydraulics

If the temperature exceeds 79 °C, the interlocking circuit for work hydraulics intervenes:

- A signal tone is output three times, and a warning symbol is displayed full-screen for five seconds in the multifunction display.
- The main consumers of the hydraulics are switched off. If the temperature falls below 75 °C again, the main consumers can be switched on again.

Auxiliary functions such as raising, lowering and swivelling the attachments and the tipper tilt function are not switched off.

Reset menu

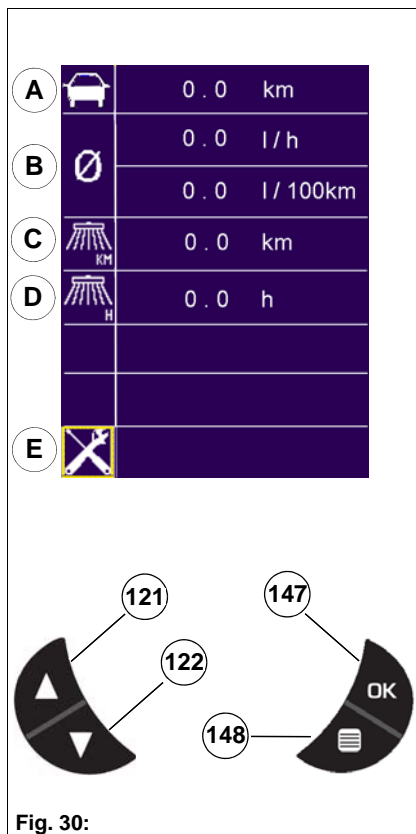



Fig. 30:

Opening the reset menu

Use the menu button **Fig. 30-148** to open the reset menu; and press the MENU button again to close it.

	<p>Note</p> <p>The reset menu:</p> <ul style="list-style-type: none"> • closes automatically if no button is pressed for five seconds and • can only be opened when the vehicle is stationary
---	--

The following displays can be processed with the reset menu:

	Display section	Comment:
A	Trip	Reset the trip display.
B	Fuel consumption	Reset the display for fuel consumption.
C	Sweeping kilometres	Reset the sweeping kilometres display.
D	Sweeping operating hours	Reset the sweeping operating hours display.
E	Options menu icon	Open the options menu.

Resetting parameters

- Use the SCROLL UP button **Fig. 30-121** or the SCROLL DOWN button **Fig. 30-122** to mark the parameter.
- Select the parameter.
 - The symbol is indicated by a yellow frame.
- Press the OK button **Fig. 30-147**.
- The parameter has been reset.

Options menu

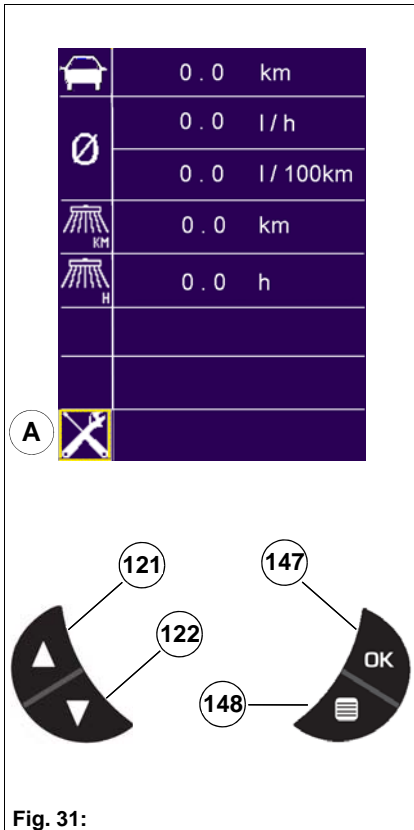



Fig. 31:

Opening the options menu

1. Use the menu button **Fig. 31-148** to open the reset menu.
2. Use the SCROLL UP button **Fig. 31-121** or the SCROLL DOWN button **Fig. 31-122** to mark the icon of the options menu **Fig. 31-A**.
 - The selected symbol is indicated by a yellow frame.
3. Press the OK button **Fig. 31-147**.
 - The options menu opens.

	<p>Note</p> <p>The options menu:</p> <ul style="list-style-type: none"> • is opened via the reset menu, • closes automatically if no button is pressed for five seconds and • is closed by pressing the MENU button.
---	--

The following displays can be edited with the options menu **Fig. 32**:

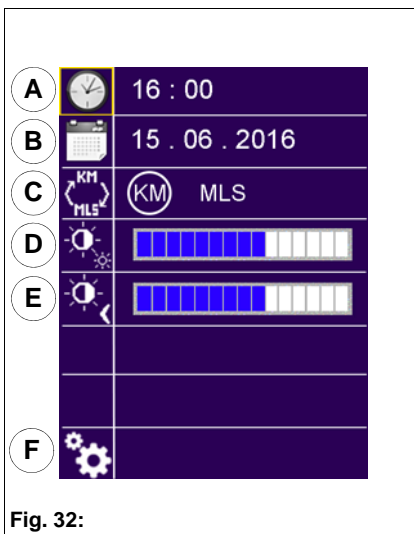

Fig. 32:

	Display section	Remark
A	Time	Set the time.
B	Date	Set the date.
C	Units	Set the unit: kilometres or miles
D	Display brightness Daytime driving	Set the brightness of the display when the light is switched off
E	Display brightness Nighttime driving	Set the brightness of the display when the light is switched on
F	Display size icon	Open the selection menu for display sizes.

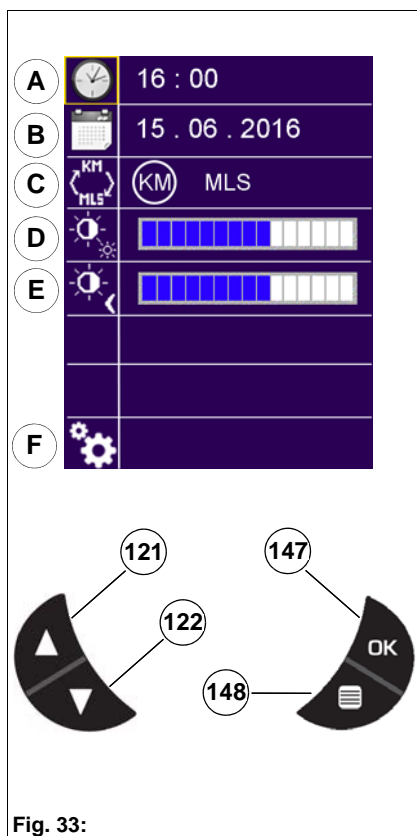

Fig. 33:

Setting the time

1. Select the symbol **Fig. 33-A**.
2. Press the OK button **Fig. 33-147**.
 - The display of the hours is indicated by a yellow frame.
3. Use the SCROLL UP button **Fig. 33-121** or the SCROLL DOWN button **Fig. 33-122** to set the desired hour.
4. Press the OK button **Fig. 33-147**.
 - The display of the minutes is indicated by a yellow frame.
5. Use the SCROLL UP button **Fig. 33-121** or the SCROLL DOWN button **Fig. 33-122** to set the desired minute.
6. Press the OK button **Fig. 33-147** to save the set time.

Setting the date

- Select the symbol **Fig. 33-B**.
- Press the OK button **Fig. 33-147**.
 - The display of the day is indicated by a yellow frame.
- Use the SCROLL UP button **Fig. 33-121** or the SCROLL DOWN button **Fig. 33-122** to set the desired day.
- Press the OK button **Fig. 33-147**.
 - The display of the month is indicated by a yellow frame.
- Use the SCROLL UP button **Fig. 33-121** or the SCROLL DOWN button **Fig. 33-122** to set the desired month.
- Press the OK button **Fig. 33-147**.
 - The display of the year is indicated by a yellow frame.
- Use the SCROLL UP button **Fig. 33-121** or the SCROLL DOWN button **Fig. 33-122** to set the desired year.
- Press the OK button **Fig. 33-147** to save the set date.

Kilometres/Miles switch-over

- Select the symbol **Fig. 33-C**.
- Use the OK button **Fig. 33-147** to toggle between kilometres (km) and miles (mils).
 - The selected symbol is indicated by a yellow frame.

Setting the display brightness during daytime

- Select the symbol **Fig. 33-D**.
- Press the OK button **Fig. 33-147**.
 - The bar is highlighted yellow.
- Use the SCROLL UP button **Fig. 33-121** or the SCROLL DOWN button **Fig. 33-122** to set the desired value.
- Press the OK button **Fig. 33-147**.

Selection menu for display sizes

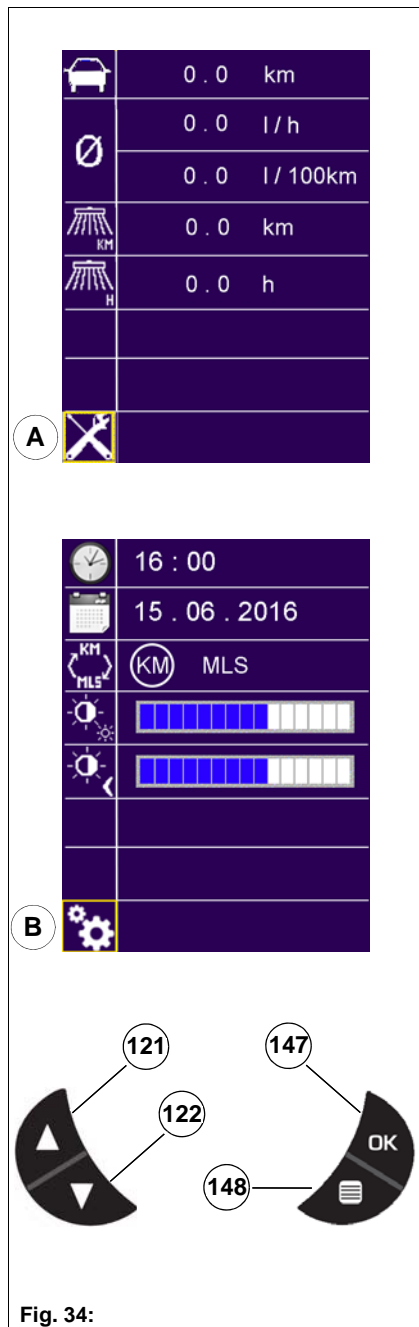

Opening the selection menu for display sizes

1. Use the menu button **Fig. 34-148** to open the reset menu.
2. Use the SCROLL UP button **Fig. 34-121** or the SCROLL DOWN button **Fig. 34-122** to mark the icon of the options menu **Fig. 34-A**.
 - The selected symbol is indicated by a yellow frame.
3. Press the OK button **Fig. 34-147**.
 - The options menu opens.
4. Use the SCROLL UP button **Fig. 34-121** or the SCROLL DOWN button **Fig. 34-122** to mark the icon of the selection menu for display sizes **Fig. 34-B**.
 - The selected symbol is indicated by a yellow frame.
5. Press the OK button **Fig. 34-147**.
 - The selection menu for display sizes opens.



Note

The selection menu for display sizes:

- is opened via the options menu,
- closes automatically if no button is pressed for five seconds and
- is closed by pressing the MENU button.

The following displays can be edited with the selection menu for display sizes **Fig. 35**:

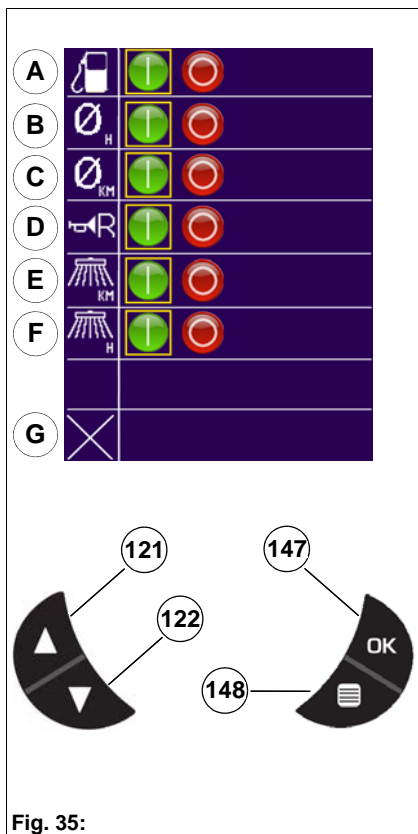

Fig. 35:

	Display section	Remark
A	Fuel consumption	Display of the current fuel consumption
B	Fuel consumption Average (l/h)	Display of average fuel consumption in litres per hour
C	Fuel consumption Average (l/100 km or l/100 mls)	Display of average fuel consumption in litres per 100 km or litres per 100 miles
D	Reverse warning buzzer	Activate/Deactivate the reverse warning buzzer
E	Work mode kilometres	Display of the kilometres travelled in work mode
F	Work mode hours	Display of the hours travelled in work mode
G	Exit	Exit the selection menu for display sizes

Activating/Deactivating the desired display:

- Use the SCROLL UP button **Fig. 35-121** or the SCROLL DOWN button **Fig. 35-122** to select the symbol **Fig. 35-A, B, D, E or F**.
 - The selected symbol is indicated by a yellow frame.
- Deactivate or activate the desired display by pressing the OK button **Fig. 35-147**.
 - The respective symbol is indicated by a yellow frame.

To exit the selection menu for display sizes, select the icon EXIT **Fig. 35 -G** and confirm.

Symbol	Colour	Meaning
	Red	Deactivate
	Green	Activate

2.2.6 Light and signal system

	<p>Note</p> <p>Follow the regulations of your country when using the light and signal systems described.</p>
---	---

Daytime running lights

When starting the engine, the daytime running lights are switched on automatically. Parking light, rear lights and numberplate light remain switched off. Daytime running lights are less bright than the low beam.

- When driving, switch on the appropriate light.
- The daytime running lights are automatically switched off when the parking light is switched on.
- Daytime running lights with activated auxiliary headlights (option): When starting the engine, the parking light / low beam is switched on automatically. Additionally, the rear lights and the numberplate light are on. The headlight flasher can be operated. Permanently switched on high beam, switching on of the working lights and the rear fog light are not possible.

Low beam switch

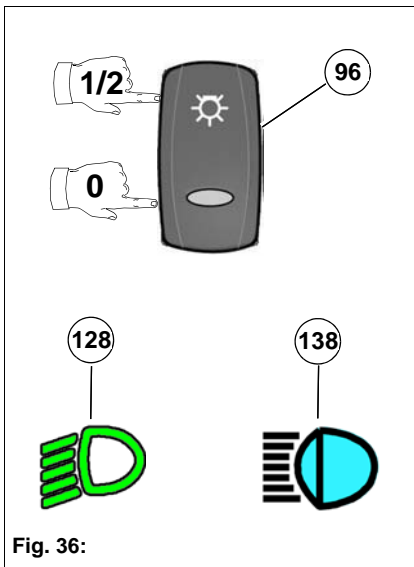



Fig. 36:

Switch **Fig. 36-96** in the centre console serves the following functions:

- Switching the headlights (parking light, low beam), clearance lights, rear lights and instrument lighting on and off.

Parking light, low beam		
1.	<ul style="list-style-type: none"> • Press the switch on symbol into stage 1. 	<ul style="list-style-type: none"> • Parking light on • Telltale in the switch on • Instrument lighting dimmed to set value • Search lighting in the switch / tip switch on
2.	<ul style="list-style-type: none"> • Press the switch on symbol into stage 2. 	<ul style="list-style-type: none"> • Low beam Fig. 36-128 or high beam Fig. 36-138 on (depending on the position of the combined switch Fig. 4-53) • Low beam telltale Fig. 36-128 on • Telltale in the switch on • Instrument lighting on
OFF	<ul style="list-style-type: none"> • Press the switch at the bottom 	<ul style="list-style-type: none"> • Parking light and low beam off • Telltale in the switch off • Low beam telltale Fig. 36-128 off • Instrument lighting off

	<p>Note</p> <p>If the ignition is switched off when the low beam or high beam is switched on – key in the ignition switch Fig. 6-107 in position 0 – only the parking light is on!</p>
---	---

Auxiliary headlights switch (option)

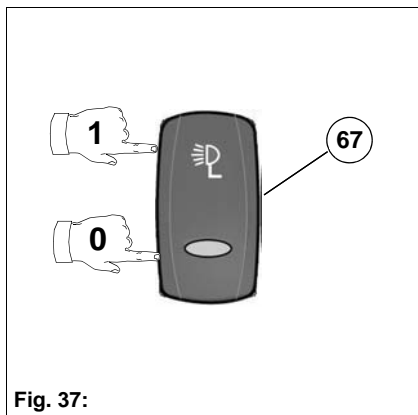

Fig. 37:

Auxiliary headlights are required when working with front-mounted equipment that cover the lower light systems, e.g. winter use with snow plough. The switch **Fig. 37-67** to switch over from lower main headlights and turn indicators to the auxiliary headlights and upper turn indicators is located underneath the cover below the fuse box.

Auxiliary headlights switch (option)		
ON	<ul style="list-style-type: none"> • Press switch on symbol. 	<ul style="list-style-type: none"> • Auxiliary headlights in operation • Telltale in the rocker switch lights up • Daytime running lights off
OFF	<ul style="list-style-type: none"> • Press the switch at the bottom. 	<ul style="list-style-type: none"> • Lower headlights in operation • Telltale off • Daytime running lights on



Note

The headlight beam adjustment **Fig. 5-83** does not affect the auxiliary headlights.

Combined switch on the steering column

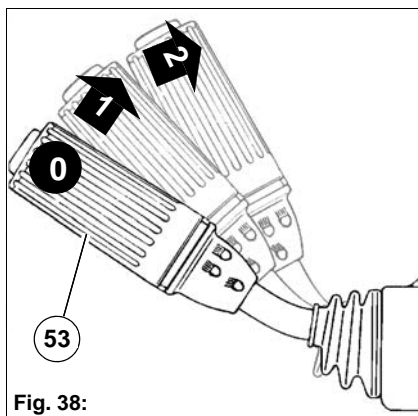

Fig. 38:

The combined switch **Fig. 38-53** on the steering column serves the following functions:

- Operating the headlights (low beam / high beam)
- Operating the headlight flasher
- Operating the turn indicators
- Operating the horn
- Operating the wipers and windscreen washer unit

Low beam / high beam / headlight flasher		
0	<ul style="list-style-type: none"> • Combined switch in the home position 	<ul style="list-style-type: none"> • High beam off • Telltale off
1	<ul style="list-style-type: none"> • Pull up the combined switch 	<ul style="list-style-type: none"> • Headlight flasher on • Telltale on
2	<ul style="list-style-type: none"> • With low beam switched on, pull the combined switch upwards 	<ul style="list-style-type: none"> • High beam on • Telltale on
1	<ul style="list-style-type: none"> • With high beam switched on, pull the combined switch upwards 	<ul style="list-style-type: none"> • Low beam on • Telltale off

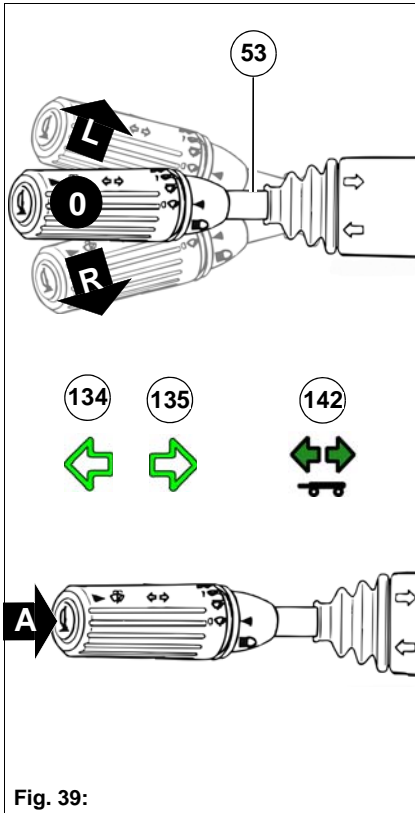

Fig. 39:

Headlight beam adjustment

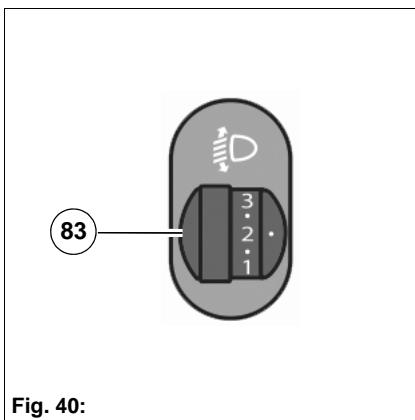

Fig. 40:

Turn indicators

LEFT (L)	<ul style="list-style-type: none"> Push the combined switch Fig. 39-53 forwards 	<ul style="list-style-type: none"> Telltale Fig. 39-134 flashes, telltale Fig. 39- also flashes in trailer operation142
RIGHT (R)	<ul style="list-style-type: none"> Pull combined switch backwards 	<ul style="list-style-type: none"> Telltale Fig. 39-135 flashes, telltale Fig. 39-142 also flashes in trailer operation
OFF (O)	<ul style="list-style-type: none"> Combined switch in centre position 	<ul style="list-style-type: none"> Telltales off



Attention

If the telltales flash approximately twice as fast as normal, this indicates that the turn indicator system is not working properly! Check the front, rear and side turn indicators immediately as well as the turn indicators on the trailer.

Horn

0	<ul style="list-style-type: none"> Combined switch in the home position 	<ul style="list-style-type: none"> Horn off
1	<ul style="list-style-type: none"> Press the push button Fig. 39-A on the combined switch 	<ul style="list-style-type: none"> Horn on

The headlight setting can be adjusted or changed for high load conditions using the headlight beam adjustment **Fig. 40-83** in order to prevent dazzling other drivers.

- Check the headlight settings after every weight change.

Headlight beam adjustment

0	<ul style="list-style-type: none"> With the low beam switched on, turn the rotary switch to position 0 	<ul style="list-style-type: none"> Home position with unloaded vehicle up to a payload of 500 kg
1	<ul style="list-style-type: none"> With the low beam switched on, turn the rotary switch to position 1, 2, 3 or 4 	<ul style="list-style-type: none"> Payload of 500 kg to 1000 kg
2		<ul style="list-style-type: none"> Payload of 1000 kg to 1500 kg
3		<ul style="list-style-type: none"> Above 1500 kg payload
4		<ul style="list-style-type: none"> Special use with heavy rear-mounted attachment



Note

The headlight beam adjustment does not affect the settings of the auxiliary headlights (option).

The basic settings for the headlights must always be carried out by your authorised Hako dealer. The headlight beam adjustment must be in home position (0) for this purpose!

Rear fog light tip switch

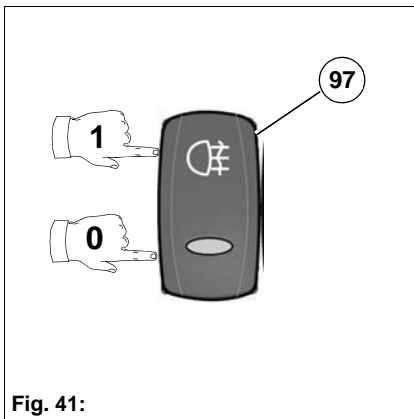

Fig. 41:

The tip switch **Fig. 41-97** for the rear fog light is located in the centre console.

Rear fog light		
ON	<ul style="list-style-type: none"> With the low beam switched on, press the tip switch on symbol 	<ul style="list-style-type: none"> Telltale on
OFF	<ul style="list-style-type: none"> With the low beam switched on, press the tip switch at the bottom 	<ul style="list-style-type: none"> Telltale off



Attention

Only switch on the rear fog light in poor visibility (e.g. under 50 m and at max. 50 km/h in Germany), otherwise motorists behind you will be dazzled. Follow the legal regulations.



Note

The rear fog light only goes on when the parking lights and low beam are switched on. The rear fog light can also be switched off by switching off the lights. When the lights are switched on again, the rear fog light must also be switched on again.

Working lights tip switch

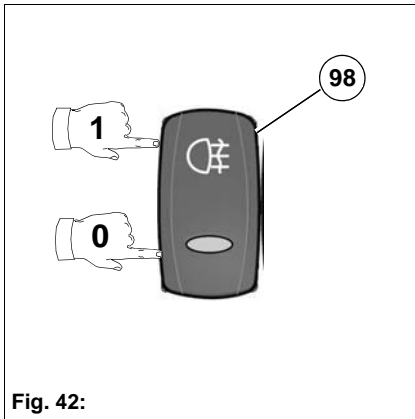

Fig. 42:

The tip switch **Fig. 43-98** for the working lights **Fig. 2-3** is located in the centre console.

Working lights		
ON	<ul style="list-style-type: none"> Press the tip switch on symbol 	<ul style="list-style-type: none"> Telltale in tip switch on
OFF	<ul style="list-style-type: none"> Press the tip switch at the bottom 	<ul style="list-style-type: none"> Telltale off

	<p>Note</p> <p>The working lights only go on when the parking lights or head-lights are switched on. The working lights can also be switched off by switching off the lights. When the lights are switched on again, the working lights must also be switched on again.</p>
--	--

Hazard warning flasher switch

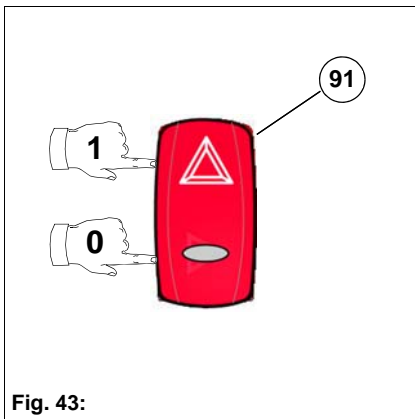

Fig. 43:

The hazard warning flasher is switched on and off with the switch **Fig. 43-91**. The switch for the hazard warning flasher is located in the centre console.

Hazard warning flasher		
ON	<ul style="list-style-type: none"> Press switch on symbol. 	<ul style="list-style-type: none"> Turn indicators flash Telltale in the switch flashes.
OFF	<ul style="list-style-type: none"> Press switch at the bottom. 	<ul style="list-style-type: none"> Turn indicators OFF Telltale off

Rotating beacon switch

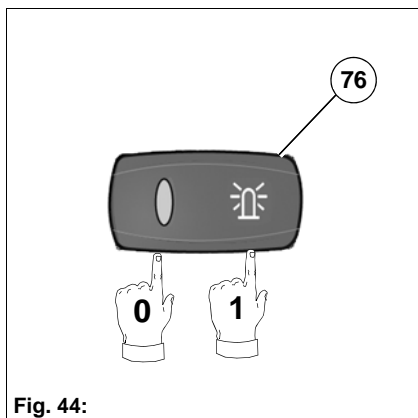

Fig. 44:

The switch **Fig. 44-76** for the rotating beacon is located in the roof console.

Rotating beacon		
ON	<ul style="list-style-type: none"> Press switch on symbol. 	<ul style="list-style-type: none"> Beacon ON Telltale in the switch on
OFF	<ul style="list-style-type: none"> Press the switch on the left 	<ul style="list-style-type: none"> Beacon OFF Telltale in the switch off



Note

Follow the legal regulations of your country, which may require you not to switch on the rotating beacon on public roads unless the road is within the vehicle's working range and the vehicle represents an obstruction to the normal flow of traffic when working.
Observe the relevant national regulations for your country.



Note

The rotating beacon can be folded down to the rear for low headroom openings. In this position, it no longer protrudes from the roof line of the cab.



Attention

A folded down rotating beacon cannot perform its warning function, as it may not be seen by the other road users.

- Always fold up the rotating beacon during use.
- Check the position of the rotating beacon after passage through low headroom openings.

Interior light

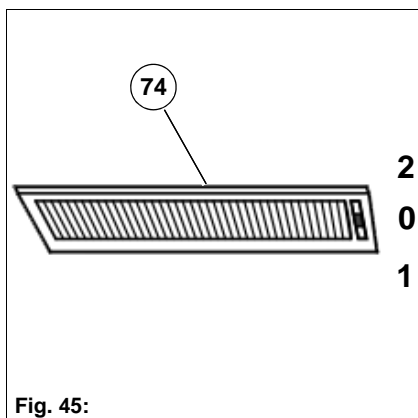

Fig. 45:

The *interior lighting* **Fig. 45-74** is located in the roof console.

Automatic interior light		
ON (1)	<ul style="list-style-type: none"> Push the switch forwards 	<ul style="list-style-type: none"> Interior light lights up permanently
OFF (0)	<ul style="list-style-type: none"> Switch in centre position 	<ul style="list-style-type: none"> Interior light off
ON (2)	<ul style="list-style-type: none"> Push the switch backwards 	<ul style="list-style-type: none"> Interior light lights up when opening one or both doors

2.2.7 Windscreen washer unit

Combined switch on the steering column

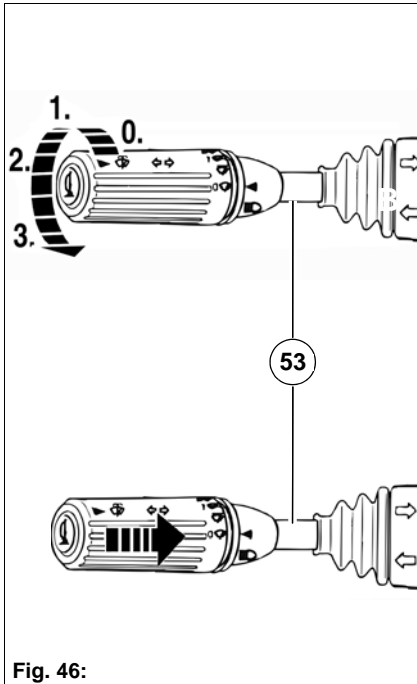

The combined switch **Fig. 46-53** on the steering column serves the following functions:

- Operating the wipers
- Operating the windscreen washer unit

Wiper		
0	• Combined switch in the home position	• Wiper OFF
1	• Turn the combined switch into the 1st stage	• Interval operation
2	• Turn the combined switch further into the 2nd stage	• Slow
3	• Turn the combined switch further into the 3rd stage	• Fast

Windscreen washer unit		
0	• Combined switch in the home position	• Windscreen washer unit OFF
1	• Push the combined switch towards the steering wheel.	• Windscreen washer unit ON • Wipers operate briefly



Attention

Do not let the windscreen wipers wipe over dry windscreens for a longer time. Wiper blades wear prematurely due to this and the wiper motor can overheat! Switch the windscreen wipers off with dry windscreens.



Note

The tank for the windscreen washer unit is located behind the passenger seat.

2.2.8 Heating and ventilation

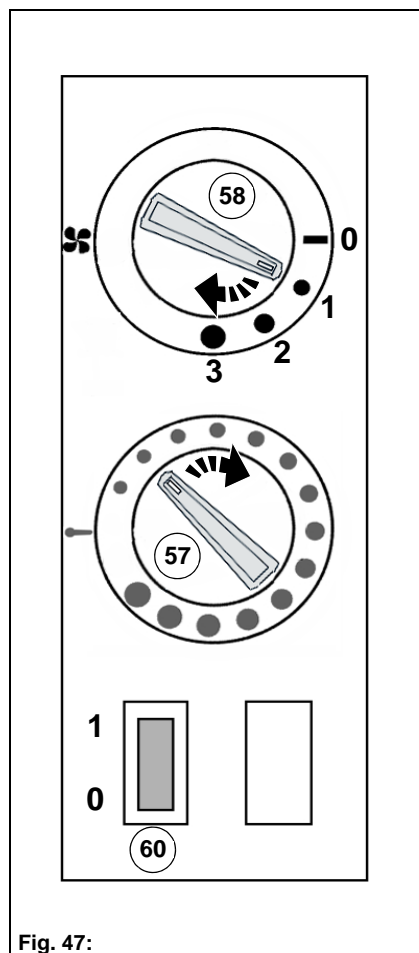

Fig. 47:

The rotary switch for the heating **Fig. 47-57** and the ventilation **Fig. 47-58** of the vehicle cab are located behind the driver's seat.



Danger

Good viewing conditions contributing to traffic safety are guaranteed only if all windows are free of ice, snow and condensation. There is a risk of accidents.

- Make yourself familiar with the correct operation of the heating and ventilation system as well as de-moisturising/defrosting the windows.
- Maximum heating power and fast thawing of the windows can be achieved only if the engine has reached its operating temperature.



Note

The vehicle is equipped with a warm-water suction fan heating. The vehicle heater can be set to 2 operating conditions:

- Ventilating with fresh air
- Heating

The air flow is transported by a 3-stage suction fan to the heater vents of the windscreen and through the legroom heater vents into the vehicle cab.

Rotary switch Fig. 47-57 for temperature

Warmer	• Turn the rotary switch clockwise
Colder	• Turn the rotary switch anti-clockwise

Rotary switch Fig. 47-58 for suction fan

OFF	• Rotary switch in position 0	• Suction fan OFF
1st stage	• Turn the rotary switch clockwise to position 1	• Suction fan runs at 1st stage
2nd stage	• Turn the rotary switch further clockwise to position 2	• Suction fan runs at 2nd stage
3rd stage	• Turn the rotary switch further clockwise to position 3	• Suction fan runs at 3rd stage

Air circulation lever

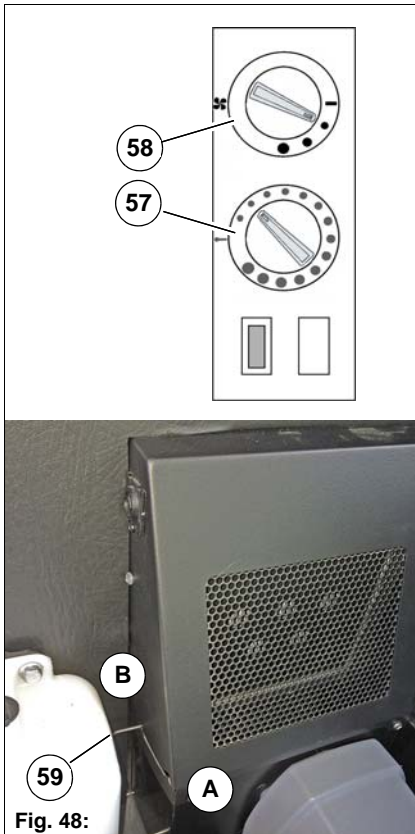

The air circulation lever **Fig. 48-59** is intended for quick clearing/defrosting of the windscreen:

1. Start the vehicle.
2. Swivel air circulation lever to **Fig. 48-A**
3. Use the rotary switch **Fig. 48-58** to switch the suction fan to the **3rd stage**
4. Turn the rotary switch **Fig. 48-57** for the temperature setting to warm
5. Switch on the switch **Fig. 49-75** for heated windscreen (option)

Air circulation control lever		
A	<ul style="list-style-type: none"> Swivel the lever to Fig. 48-A 	<ul style="list-style-type: none"> Air is drawn in from the outside.
B	<ul style="list-style-type: none"> Swivel the lever to Fig. 48-B 	<ul style="list-style-type: none"> Air circulation position, air is drawn from the interior.

Tip switch for heated windscreen and heated outside rearview mirror (option)

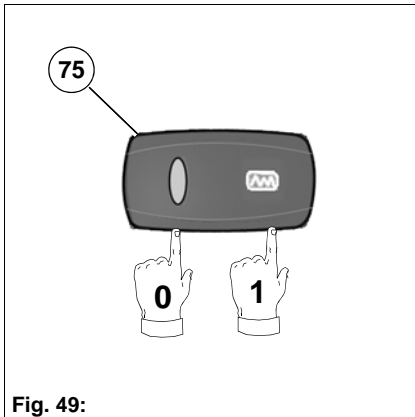

The tip switch **Fig. 49-75** for the heated outside rearview mirror / windscreen is located in the roof console.

Heated windscreen and heated outside rearview mirror		
ON	<ul style="list-style-type: none"> Press the tip switch on symbol (1) 	<ul style="list-style-type: none"> Telltale on
OFF	<ul style="list-style-type: none"> Press the tip switch (0) on the left 	<ul style="list-style-type: none"> Telltale off

Note
 Switch off heated windscreen / outside rearview mirror again when the windscreen / outside rearview mirror is clear again. High power consumption!
 The heated windscreen / outside rearview mirror switches of automatically after approx. 10 minutes (time relay).

2.2.9 Air conditioning system

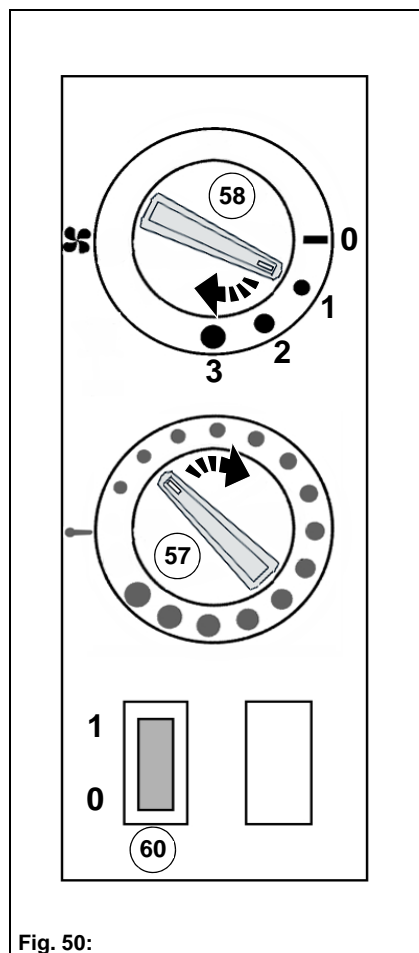

Fig. 50:

The air conditioning system is well suited for dehumidifying the air in the vehicle, thereby preventing condensation on the windows.



Danger

The coolant in the air conditioning system is under high pressure. There is a risk of injury!
If the coolant comes into contact with skin, there is an additional risk of frostbite!

- Do not open any parts of the air conditioning system.
- Have maintenance work on the air conditioning system done only by an authorised workshop.



Attention

Excessive temperature differences can be harmful to health. A temperature difference of 5 to 6°C to the external air is recommended.



Note

A suction fan blows the air to the air vents. The air conditioning system can only work when the engine is running. To put the air conditioning system into operation, use the rotary switch **Fig. 50-58** to set the suction fan at least to stage 1.

Switch Fig. 50-60 for air conditioning system

ON	<ul style="list-style-type: none"> • Push the switch forwards 	<ul style="list-style-type: none"> • Telltale on • Suction fan in 1st stage
OFF	<ul style="list-style-type: none"> • Push the switch backwards 	<ul style="list-style-type: none"> • Telltale off

2.2.10 Auxiliary heater (independent vehicle heating (option))

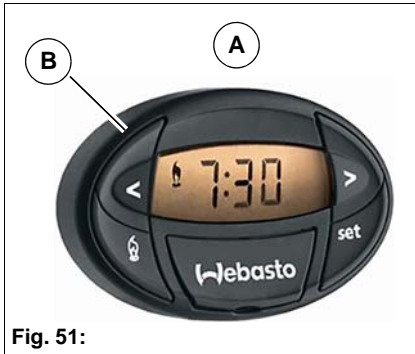

Fig. 51:

The vehicle can be fitted with an auxiliary heater as an optional extra. The control unit **Fig. 51-A** of the auxiliary heater is located behind the driver's seat, behind the control unit for the heating adjustment.

	<p>Danger</p> <p>At petrol stations and fuelling systems as well as places where combustible vapours or dust can accumulate (e.g. near fuel, coal or wood dust or grain storage areas or similar) – there is a risk of explosion!</p> <ul style="list-style-type: none"> • Switch auxiliary heater off before approaching these areas. Combustion gases contain toxic substances. There is a risk of poisoning and asphyxiation! • Switch off the auxiliary heater before entering enclosed areas.
	<p>Note</p> <p>To heat the cab, turn the rotary switch for temperature setting to the "Warm" position and the turn-push knob to ventilation stage 1, otherwise only the engine will be preheated.</p> <p>The preselect timer Fig. 51-B can be used to set the heating times. Read the separate operating manual of the auxiliary heater manufacturer.</p> <p>Additional information on the operation of the auxiliary heater and preselect timer can be found in the separate operating manual of the auxiliary heater manufacturer.</p>
	<p>Attention</p> <p>Never actuate the battery master switch neither during operation of the independent vehicle heater nor during the after-run time.</p>

2.2.11 Driver's seat / Passenger seat

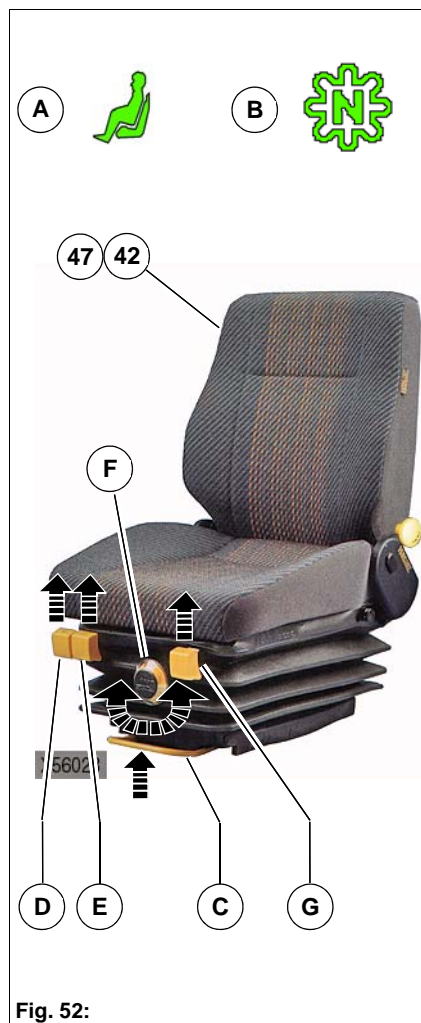

Fig. 52:

Standard suspension seat

The passenger seat **Fig. 52-42** is available in the following versions:

- Unsprung seat and
- Standard suspension seat (option)

The driver's seat **Fig. 52-47** is available in the following versions:

- Standard suspension seat
- Suspension seat in comfort version (option) and
- Air-cushioned seat (option)

Please refer to the operating manual of the manufacturer!



Danger

Never change the seat position when driving.

Risk of accidents

- Adjust the seat before moving the vehicle. Observe the operating manual of the seat manufacturer.



Note

The driver's seat is equipped with a seat contact switch. It is only possible to drive the vehicle when a person is seated on the driver's seat. If the seat contact switch is not loaded and the drive switch or the accelerator pedal is actuated, the symbol **Fig. 52-A** appears in the multifunction display. If no pressure is placed on the driver's seat whilst driving, the vehicle stops.



Note

If no pressure is placed on the driver's seat (e.g. the driver gets out) and the drive switch is not in the neutral position, the symbol **Fig. 52-B** is shown in the multifunction display once the driver's seat is loaded again. Shift the drive switch into the neutral position and move off.

Sit down on the seat and carry out the following settings:

Adjusting the longitudinal position

- Pull the lever **Fig. 52-C** upwards.
- Move the seat forward or backward.
- Release the lever **Fig. 52-C** and let the driver's seat engage.

Adjusting the height of rear seat edge

- Pull the lever **Fig. 52-D** upwards.
- Adjust the seat to the desired height by shifting your weight accordingly in the rear seat area.
- Release the lever **Fig. 52-D**.

Adjusting the height of front seat edge

- Pull the lever **Fig. 52-E** upwards.
- Adjust the seat to the desired height by shifting your weight accordingly in the front seat area.
- Release the lever **Fig. 52-E**.

Adjusting the seat suspension

- Use the handwheel **Fig. 52-F** to continuously adjust the seat suspension to the driver's weight (50 – 130 kg). Turn the handwheel **Fig. 52-F** to adjust the seat suspension.

Adjusting the tilt of the backrest

- Press your back lightly against the backrest while simultaneously pulling the lever **Fig. 52-G** upwards.
- Release the lever **Fig. 52-G** and let the backrest engage with an audible click.

Comfort version of the suspension seat (option)

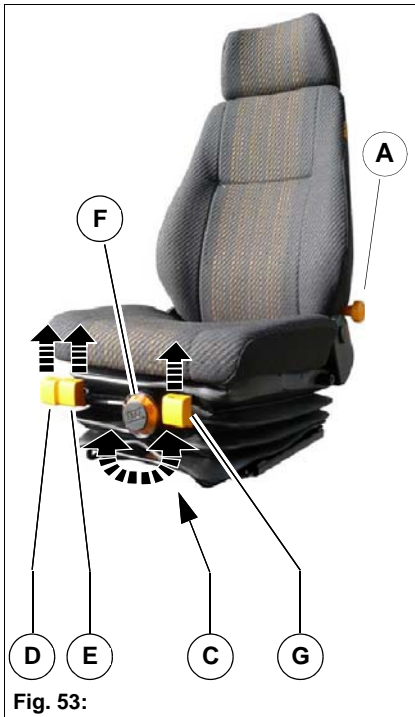

The comfort version of the suspension seat features a high backrest and a mechanically adjustable lumbar support, and can be equipped with electric seat heating.

Adjusting the lumbar support (option)

- Use the handwheel **Fig. 53-A** to adjust the intensity of the lumbar support.

Switching on the seat heating (option)

- Use the switch **Fig. 6-104** on the dashboard to switch on and off the seat heating.



Note

The seat heating only works when the diesel engine is running.

Head rest (option)

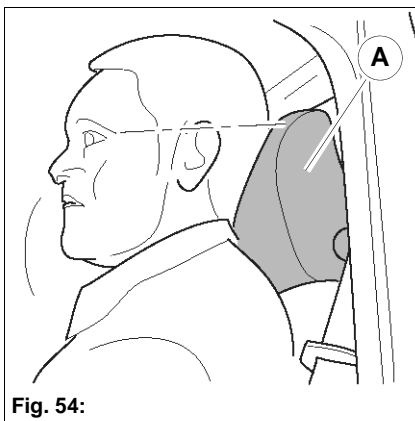

The vehicle can be optionally equipped with head rests **Fig. 54-A**.



Danger

Driving with the head rest set incorrectly means risk of injury!

- *Adjust the head rest so that the back of your head is supported at around the height of your ears!*

Adjusting the head rest

- Pull up or push down the head rest.

Air-cushioned seat (option)



Fig. 55:

The air-cushioned seat features an integrated belt, a mechanically adjustable lumbar support and electric seat heating.

Adjusting the height of the rear seat edge

- Pull the lever **Fig. 55-A** upwards.

Adjusting the height of the front seat edge

- Pull the lever **Fig. 55-B** upwards.

Adjusting the suspension

- Move the lever **Fig. 55-C** to the left or right to adjust the height and hardness.



Note

Moving the lever **Fig. 55-C** to the left or right supplies or removes air (pneumatic suspension with compressor). The compressor can only be switched on when the diesel engine is running.

Adjusting the longitudinal position

- Pull the lever **Fig. 55-D** upwards and push the seat forwards or backwards.
- Release the lever **Fig. 55-D** and let the seat engage.

Adjusting the lumbar support

- Use the handwheel **Fig. 55-E** to adjust the intensity of the lumbar support.

Adjusting the tilt of the backrest

- Use the handwheel **Fig. 55-F** to adjust the tilt of the backrest.

Switching on the seat heating

- Use switch **Fig. 55-G** to switch on the seat heating. Two intensity levels can be set. The seat and the backrest are heated.



Note

The seat heating only works when the diesel engine is running.

2.2.12 Seat belt

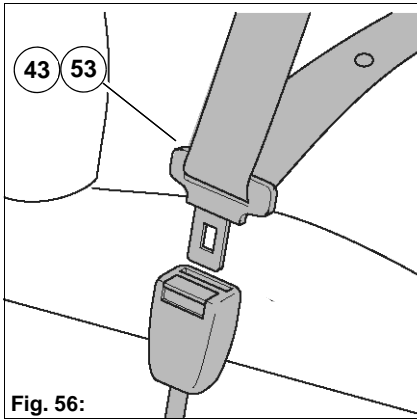

The three-point automatic seat belts **Fig. 56** are for the safety of the driver and the passenger. Fasten the seat belt before each journey.



Danger

- Driving or working without the seat belt means risk of injury!
- Make sure that the seat belt is not twisted.
- The seat belt must run across the lap – not the stomach – and must always fit securely.
- Do not place the seat belt over hard, sharp-edged or breakable objects (tools, metre rules, glasses, pens) on your person.
- Never use one seat belt to secure two persons (e.g. children).
- Check seat belt condition regularly. Have damaged parts replaced immediately by your authorised Hako dealer.
- Always keep the seat belt clean, as heavy contamination can affect the function of the automatic belt.
- The belt lock must not be jammed by foreign objects (paper or similar), otherwise the buckle latch will not be able to lock into place.
- The seat belt will be stretched after an accident, and can no longer be used. Therefore, in the event of another accident, this overstretched seat belt will not provide sufficient safety.
 - Replace the seat belt after an accident.
 - Check anchor points and seat attachment for additional load resistance.

Fastening the seat belt

- Hold the belt strap at the buckle latch **Fig. 57-A** and pull it slowly and evenly across the lap to the belt lock **Fig. 57-B**.
- Insert the buckle latch **Fig. 57-A** into the belt buckle **Fig. 57-B** until it snaps in audibly (**check by pulling**).
- Re-tension the seat belt by pulling on the end.
- The seat belt must always lie firmly against your pelvis.

Taking off the seat belt

- Hold the seat belt.
- Press the red button on the belt lock **Fig. 57-B**.
- The buckle latch **Fig. 57-A** pops out of the belt lock by spring pressure.
- Slowly return the seat belt to the retractor.

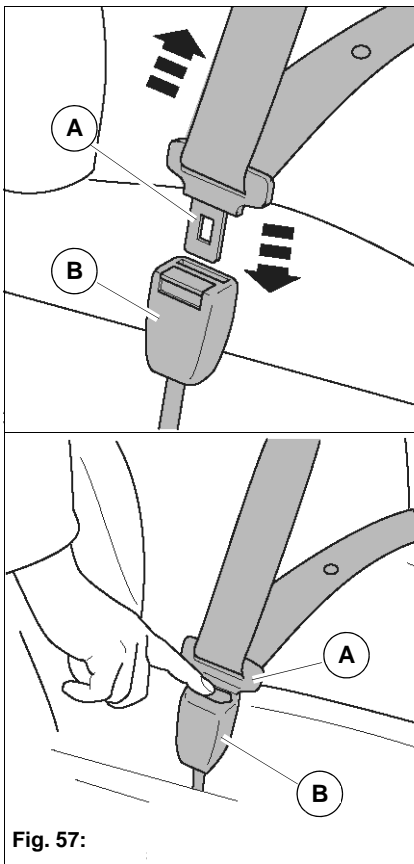

Fig. 57:



Note

When pulled slowly, the automatic seat belt ensures full freedom of movement. However, it is blocked in sudden braking. The automatic seat belt can also block when driving over pot-holes or similar uneven surfaces.

Clean the belt strap with lukewarm water only; do not use solvents.

2.2.13 Steering column



Danger

There is a risk of accidents when adjusting the steering column when driving or while driving with the steering column unlocked!

- Adjust the steering column before moving the vehicle.
- Always lock the steering column securely after adjustment.

Adjusting the steering column



Fig. 58:

The height and inclination of the steering column can be adjusted to suit the driver's height. Adjust the steering column to your height so that all operating controls can be reached comfortably and the view of the dashboard is not restricted.

- Sit down on the seat.
- Adjust the inclination of the steering wheel:
Press the locking lever **Fig. 58-A** on the steering column downwards.
- Adjust the height of the steering wheel:
Pull the locking lever **Fig. 58-A** on the steering column upwards.
- After successful adjustment: Hold the steering column in the set position, press the locking lever on the steering column downwards up to the stop. The steering column is locked.

2.2.14 Doors

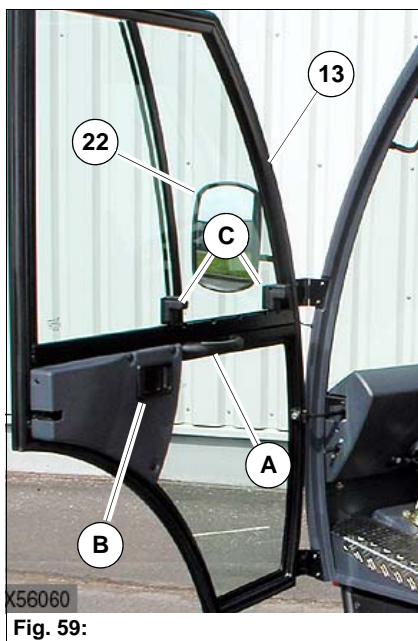

Fig. 59:

Door lock



Danger

There is a risk of accidents when driving with open doors **Fig. 59-13!**

- The doors must remain closed when driving on public roads and when working.
- Always use the handles **Fig. 59-A** when closing the doors!

Use the door key to open and close the doors from the outside.

Opening from the inside

Pull the lever **Fig. 59-B** upwards and open the door from the inside.

Left/Right side window

The left and right side windows are opened or closed with the catches **Fig. 59-C**. Push the catches up and move the window correspondingly.

Outside mirrors



Danger

There is a risk of accidents when driving with unadjusted outside rearview mirrors!

Adjust the outside mirrors **Fig. 59-22** so that the roadway and the rear work area are completely visible.

2.2.15 EU control device (option)

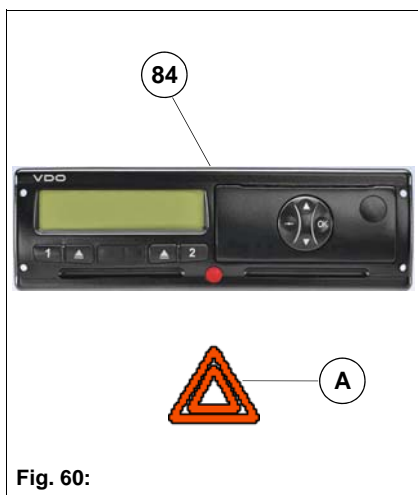

Fig. 60:

The EU control device **Fig. 60-84** is located in the roof console.

The EU control device records the working and rest periods and the speed and distance travelled.

For information on the operation of the digital EU control device, refer to the separate operating manual of the manufacturer.

Malfunctions are shown in the display of the EU control device.



Note

Obey national road traffic rules (e.g. StVZO in Germany) and the operating manual provided by the manufacturer of the digital EU control device.

Malfunctions are displayed by the warning symbol **Fig. 60-A** in the multi-function display.

2.2.16 Socket, cigarette lighter

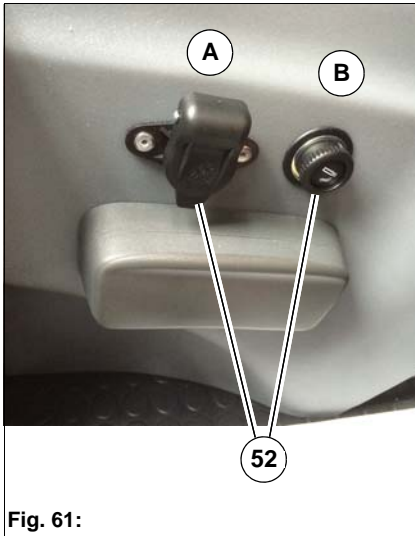

Fig. 61:

The cigarette lighter and socket **Fig. 61-52** are located in the centre console above the ashtray.



Danger

There is a risk of burns when the cigarette lighter is heated!

- Do not touch the hot heating coil.
- Do not place the hot cigarette lighter on a flammable surface.

Socket

Socket for attachments.

The 3-pin socket **Fig. 61-A** has the following functions:

- + terminal (terminal X, ignition ON)
- C3 signal
- – terminal (ground)

Cigarette lighter

When using as cigarette lighter:

- Push in the cigarette lighter **Fig. 61-B**.
- The cigarette lighter returns to its initial position after a couple of seconds and can be pulled out to light a cigarette.

When using as a socket:

- Pull out the cigarette lighter **Fig. 61-B** and store in an appropriate place.
- The opening serves as a 12 V socket, max. 10 A.



Note

The cigarette lighter / socket also works when the diesel engine is switched off, but this uses up the battery.

2.2.17 Brakes

General Notes

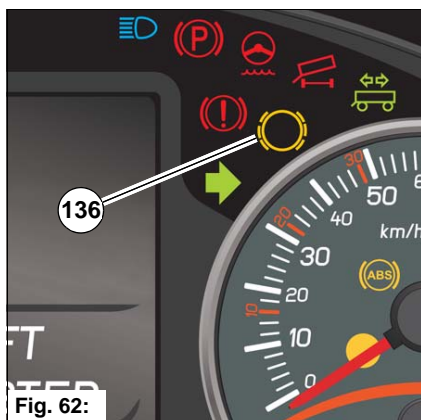

Fig. 62:

Brake lining wear is highly dependent on:

- Conditions of use, e.g. short or long distance travel
- Flat land, mountains
- Driving style

Therefore, it may be necessary to also have the brake linings checked by your authorised Hako dealer between the specified maintenance intervals. The warning light **Fig. 62-136** in the indicating device lights up when the brake linings reach the wear limit. In this case, have the brake linings replaced by an authorised workshop as soon as possible.

The braking effect may be negatively affected by:

- Dampness and/or coldness
 - Apply the brakes until they are dry.
- De-icing salt
 - The salt layer on brake discs and brake linings needs to be worn off first when braking.
- Overheating
 - Do not "ride" the brakes by pressing the pedal lightly.
 - When driving on slopes, reduce speed in good time.
 - Utilise the braking effect of the diesel engine.
 - During long downhill stretches, also brake in intervals.
 - Drive in a forward-looking fashion.



Note

The warning light **Fig. 63-137** indicates brake fluid loss and a fault in the vacuum system of the power brake. During a fault in the vacuum system, the "brake maintenance" symbol is additionally shown in the multifunction display. When the warning light **Fig. 63-137** lights up, have the causes inspected and repaired by an authorised workshop. Drive slowly on your way there.

Power brake

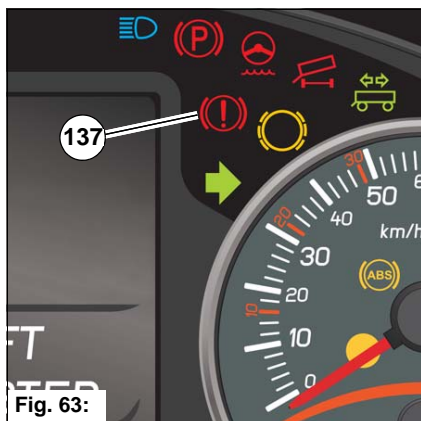

Fig. 63:

The power brakes work with negative pressure which is only generated while the engine is running.

The warning light **Fig. 63-137** in the indicating device indicates brake fluid loss.



Danger

The power brake does not work when the engine is switched off or in the event of a brake circuit failure. The brake pedal has to be pressed much harder. Take this into account, especially when towing the vehicle. There is a risk of accidents!

Seek advice from an authorised workshop, drive slowly and set considerably higher pedal powers.

Anti-blocking system (ABS)

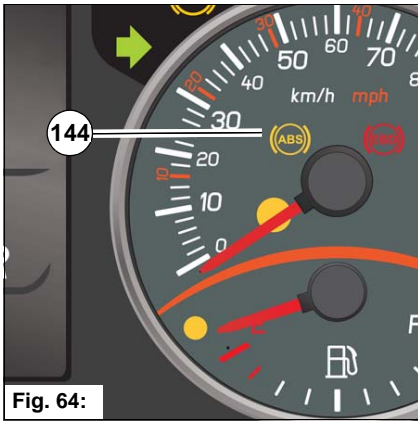

Fig. 64:

The ABS makes a significant contribution towards increasing the active driving safety of the vehicle as blocking of the wheels is prevented at a driving speed above approx. 3-4 km/h.

This way, steering capability and stability of the vehicle are maintained and the braking distance minimised even when the brakes are fully applied.



Danger

Relying on the ABS to shorten the braking distances should not lead to a careless driving style. It is primarily designed as a safety reserve in difficult situations. ABS is also not capable of overcoming physical limits. This must be taken into account, especially when the road is slippery or wet. There is a risk of accidents!

- Never allow a false sense of security persuade you to drive in a careless manner.
- Do not overspeed, maintain safe distances.
- Take care when driving around curves. Braking in curves is subject to particular physical laws that cannot be overthrown by the ABS.
- When the ABS becomes active, immediately adapt the speed to the road and traffic situation.
- Do not take any safety risks.

However, it must not be expected that the ABS will reduce the braking distances under all circumstances.

- When driving on soft and deep surfaces, e.g. sand, gravel or snow on a slippery underground, drive cautiously and slowly; the braking distance may even then be somewhat longer. However, stability and steering capability are guaranteed.
- If the vehicle starts to skid when at a standstill and with locked wheels on steep gradients with a low friction value, then briefly release the brakes and apply them again.
- On vehicles with ABS, constant pressure on the brake pedal is more effective than interval braking. Pumping motions on the brake pedal may reduce the braking effect of the ABS, thereby increasing the braking distance.

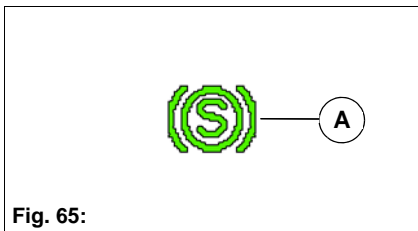

Fig. 65:



Note

The ABS is switched off with activated differential lock, four-wheel steering, freely locked rear axle and in synchronisation mode of the steering axle.

The ABS warning light Fig. 64-144 lights up if the ABS is switched off due to special driving conditions or a fault. In case of the said special driving conditions, the symbol "brake special mode" Fig. 65-A additionally lights up in the multifunction display. The system is in EBD mode (see page 97), the wheels may block. In this condition, adapt your driving style accordingly. If there is a system fault, seek assistance from a workshop for troubleshooting; drive carefully. When the warning light lights up, vehicle speed is limited to 25 km/h.

Electronic brake-force distribution system (EBD)

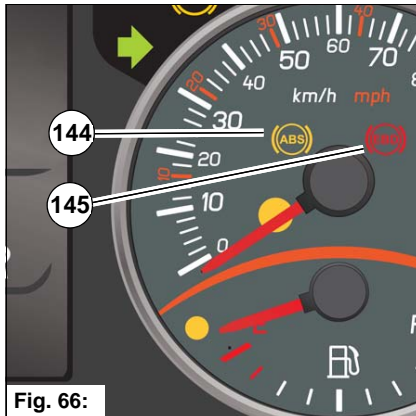

Fig. 66:

The electronic brake-force distribution system (EBD) supports the ABS control via an early assessment of the expected blocking sequence of the axles and corresponding brake force distribution. If the ABS system is fully functional, this function cannot be felt.

If the ABS is switched off due to a special driving condition (see page 96) or as the result of a system fault (the ABS warning light **Fig. 64-144** lights up), the EBD still ensures the blocking sequence (front axle before rear axle).



Note

If there is a severe fault in the ABS, the EBD warning light **Fig. 66-145** lights up and the blocking sequence is no longer guaranteed. The ABS warning light **Fig. 66-144** also fails to light up in this case. Immediately seek assistance from a workshop for troubleshooting; drive carefully. When the warning light lights up, vehicle speed is limited to 25 km/h.



Note

If the warning light **Fig. 66-145** appears in combination with the symbol "brake special mode", there is no fault! (see page 96)

Parking brake

Use the parking brake **Fig. 67-55** to secure the vehicle against rolling away or use it as a secondary brake if the service brake is out of operation.



Danger

Only use the parking brake instead of the service brake in an emergency, i. e. if the service brake is out of operation. The brake lights will not light up in this case, risk of accidents!
In normal operation, use the brake pedal or the hydrostatic braking effect as the brake, as the brake lights at the rear of the vehicle will only light up in this case.

Preventing the vehicle from rolling away

- Pull the parking brake upwards up to the stop (8th detent) to apply the parking brake.
 - The warning light **Fig. 68-139** in the indicating device lights up.
- Firm resistance should be felt after 6 to 8 notches.
 - If not, the parking brake is not in working order. Have the parking brake checked immediately by a specialist.



Danger

- Adopt measures against erroneous starting and unwanted movement. There is a risk of accidents!
- The braking power of the parking brake depends on the rear wheel with the lowest friction factor. When the vehicle is parked on a slope with one rear wheel placed on solid dry ground and the other rear wheel on ice or snow, the maximum braking power is determined by the friction factor between the wheel and the ice. Should the vehicle roll away, there is a risk of accidents! When parking on a slope, use wheel chocks as well.

Releasing the parking brake

- Slightly raise the parking brake, press the knob **Fig. 67-A** on the parking brake and push the parking brake downwards.
 - The parking brake is released and the warning light **Fig. 68-139** goes out.

Using the parking brake as secondary brake (only in an emergency) while driving.

- Pull the parking brake lever upwards with force **in an emergency only**.
 - When using the parking brake while driving, the warning light **Fig. 68-139** flashes and the buzzer sounds on applying the brake.



Note

The parking brake operates via a pull cable on a separate brake drum on the gear shaft.

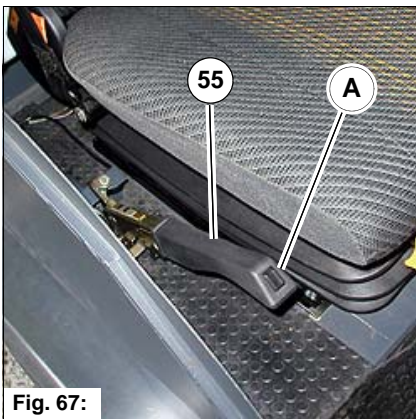

Fig. 67:

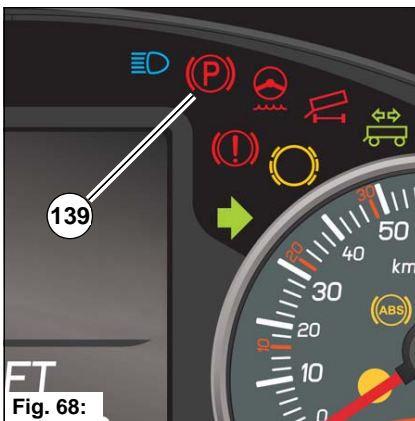

Fig. 68:

Brake pedal

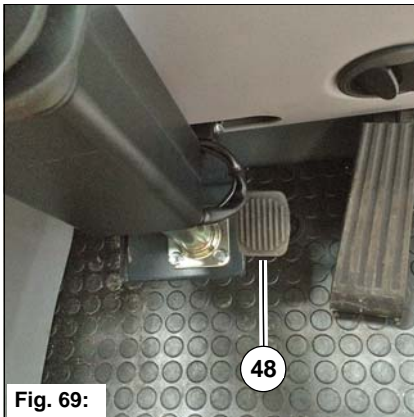

Fig. 69:

Actuating the service brake

Use the brake pedal **Fig. 69-48** to slow down the vehicle.



Danger

- Dirt accumulation in the area of the brake pedal can result in brake malfunctions. There is a risk of accidents! Always keep the brake pedal clean!

Depress the brake pedal **Fig. 69-48** according to the desired braking effect.



Note

When the vehicle is fully loaded, a higher braking pressure is required for braking.

- The pedal travel and foot power to be applied increase.
- The maximum achievable braking effect with a loaded vehicle is reduced compared to an unloaded vehicle.

Hydrostatic brake force

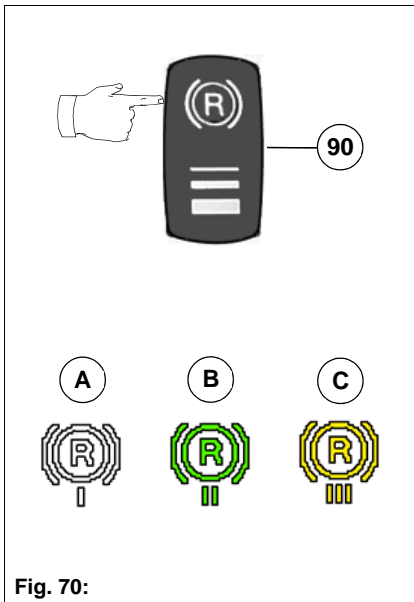

Fig. 70:

The hydraulic brake force can be adjusted with the switch **Fig. 70-90**. Press the switch according to the desired braking effect:

- Switch in stage I: slight braking effect
- Switch in stage II: medium braking effect
- Switch in stage III: strong braking effect

The respective symbol appears in the multifunction display.

- Stage I: Symbol **Fig. 70-A**
- Stage II: Symbol **Fig. 70-B**
- Stage III: Symbol **Fig. 70-C**

2.2.18 Steering

	<p>Danger</p> <p>Turning the steering wheel requires greater effort if the power steering fails – emergency steering. Take this into account, especially when towing the vehicle. There is a risk of accidents!</p> <ul style="list-style-type: none"> • Only drive the vehicle as far as the next possible stop. Only emergency steering is possible. • Adapt the towing speed to the altered steering behaviour!
---	---

General

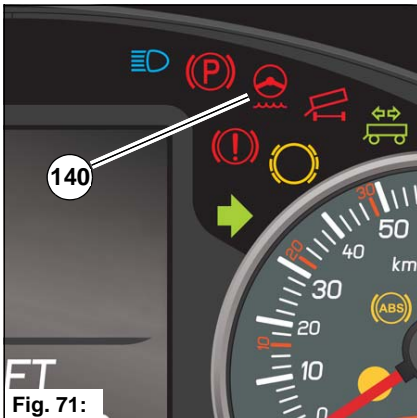

Do not turn the steering wheel to full lock for more than 15 seconds. A continuous full lock causes the servo pump to intensely heat the hydraulic oil. This can damage the servo steering system.

Each time that the steering is turned to full lock while the vehicle is at a standstill is also indicated by noise due to the heavy strain on the servo pump. In addition, the idle speed of the engine is reduced for a short time.

	<p>Danger</p> <p>If the power steering oil level / hydraulic oil level warning light Fig. 71-140 lights up, this may indicate a failure of the hydraulic steering. There is a risk of accidents!</p> <ul style="list-style-type: none"> • Reduce the vehicle speed immediately. • Drive slowly to an authorised workshop. • Rectify (or have rectified) the cause of the oil loss. • Check the hydraulic oil level in the tank and correct if required.
---	---

	<p>Note</p> <p>The steering system is only operational when the engine is running. In the event of a failure of the diesel engine or of the hydraulic power steering (e.g. failure of the pump drive), the vehicle can still be steered – emergency steering function. Check emergency steering before driving the vehicle: Always check the steering before driving with the vehicle to ensure the steering system works correctly at all times. With vehicles with four-wheel steering, check the steering in steering mode four-wheel steering. Turn the steering wheel to the left and right when the diesel engine is switched off. It must be possible to turn the steering wheel with increased force and the wheels must follow the steering movement. With four-wheel steering, pay special attention to the synchronous steering behaviour between the front and rear axle. Furthermore, check the steering system visually for leaks. If a point is not fulfilled during the test, only move the vehicle slowly and have an authorised workshop eliminate the fault.</p>
---	--

Steering modes

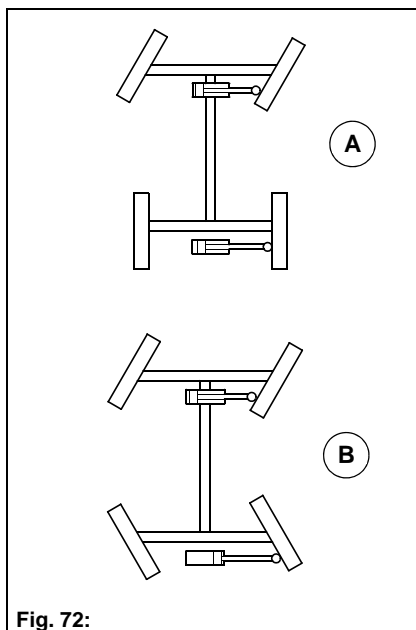

Fig. 72:

The following steering modes are available:

- Front wheel steering **Fig. 72-A**
- Four-wheel steering **Fig. 72-B**



Danger

Switch over the steering mode only when the vehicle is standing. There is a risk of accidents!

- Initially stop the vehicle.
- Synchronise the steering.

Front wheel steering

Front wheel steering can be selected in transport mode and in work mode.

Four-wheel steering

Four-wheel steering can only be selected in work mode. With this steering mode, the wheels of the rear axle are locked in the opposite direction to the wheels of the front axle. Advantage: small turning radius.

Synchronising the steering

If you want to revert back to transport mode after using four-wheel steering, the steering wheel must be moved through the straight-ahead position by turning the steering wheel slowly to the left and right. The steering mode is automatically switched to front wheel steering.

Checking the steering

To ensure that the steering system is fully functional at all times, check the steering before driving the vehicle.

With vehicles with four-wheel steering, check the steering in steering mode four-wheel steering.

Turn the steering wheel to the left and right when the diesel engine is switched off.

It must be possible to turn the steering wheel with increased force and the wheels must follow the steering movement.

With four-wheel steering, pay special attention to the synchronous steering behaviour between the front and rear axle.

Furthermore, check the steering system visually for leaks.

If a point is not fulfilled during the test, only move the vehicle slowly and have an authorised workshop eliminate the fault.

Steering mode switch

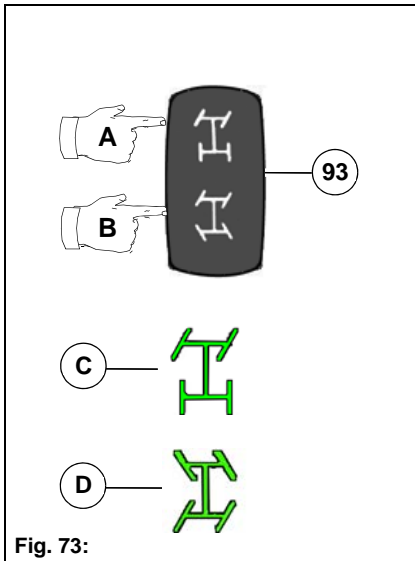

Use the tip switch **Fig. 73-93** to activate the steering mode. The respective symbol appears in the multifunction display.

Steering mode	Tip switch	Effect
Front wheel steering	<ul style="list-style-type: none"> Press the tip switch on symbol Fig. 73-A. 	<ul style="list-style-type: none"> The symbol Fig. 73-C flashes until the rear axle reaches the straight-ahead position. Front wheel steering is switched on automatically and the symbol Fig. 73-C lights up.
Four-wheel steering	<ul style="list-style-type: none"> Press the tip switch on symbol Fig. 73-B. 	<ul style="list-style-type: none"> The symbol Fig. 73-D flashes until the front axle reaches the straight-ahead position. Four-wheel steering is switched on automatically and the symbol Fig. 73-D lights up.

2.2.19 Drive

Driving mode tip switch

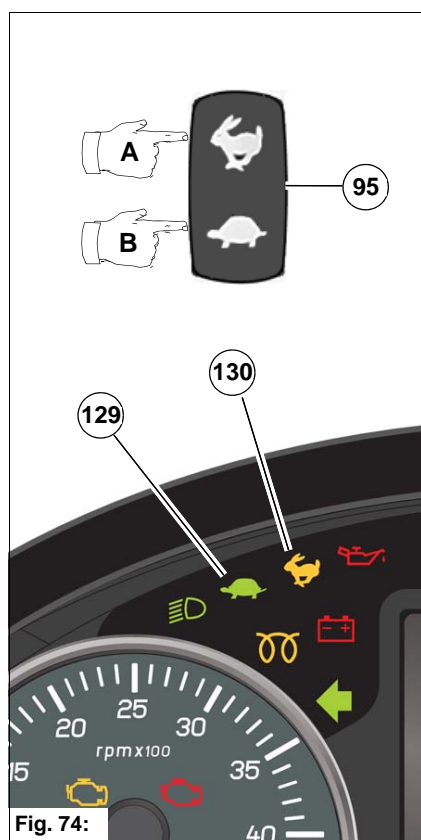

Fig. 74:

Use the driving mode tip switch **Fig. 74-95** to set the following speed levels:

- Work mode
- Offset mode
- Transport mode

Work mode

Having work mode switched on makes it possible to more accurately adapt the driving speed to the application at a higher drive torque, resulting in smooth performance. In work mode, the forward speed is 0 to 15 km/h and the reverse speed is 0 to 15 km/h.

Offset mode

Use the tip switch to interrupt work mode, e.g., for a short offset mode, and press the tip switch again to return to work mode. The speed in offset mode is 0 to 20 km/h.

Transport mode

In transport mode, the forward speed is 0 to 62 km/h and the reverse speed is 0 to 25 km/h.

Adjusting the speed levels

Switch from work mode to offset mode

- Press 1 x hare **Fig. 74-A**.

Switch from offset mode to transport mode

- Press 1 x hare **Fig. 74-A**.

Switch from transport mode to offset mode

- Press 1 x tortoise **Fig. 74-B**.

Switch from offset mode to work mode

- Press 1 x tortoise **Fig. 74-B**.

The respective symbol appears in the indicating device:

- Symbol **Fig. 74-129** for work mode / offset mode
- Symbol **Fig. 74-130** for transport mode



Note

If you want to revert back to transport mode after using four-wheel steering, the steering wheel must be moved through the straight-ahead position by turning the steering wheel slowly to the left and right. The steering mode is automatically switched to front wheel steering.

Direction indicator switch

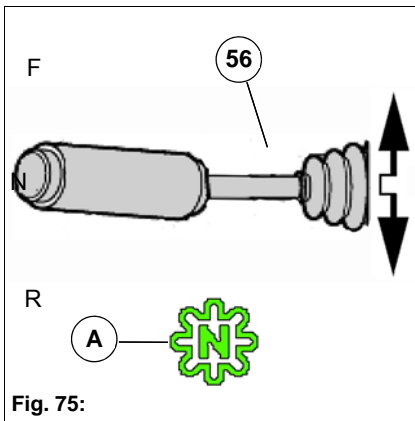

Fig. 75:

The direction indicator switch **Fig. 75-56** enables three settings:

- Forward direction
- Neutral position
- Reverse direction

	<p>Danger Strong hydrostatic braking effect when abruptly changing direction. There is a risk of accidents! Initially stop the vehicle!</p>
--	--

Adjusting the direction

Position	Drive switch	Effect
• F	• Pull the drive switch upwards and push it forwards.	• Forward travel
• N	• Drive switch in centre position	• Neutral position
• R	• Pull the drive switch upwards and push it backwards.	<ul style="list-style-type: none"> • Reverse travel • Reversing light lights up • An intermittent warning sound is output with a reverse warning device (option).

	<p>Note The engine can only be started when the drive switch is in the neutral position. If this is not the case, the symbol Fig. 75-A appears in the multifunction display.</p>
--	--

Accelerator pedal

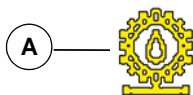

Fig. 76:

In transport mode, use the accelerator pedal **Fig. 76-49** to adapt the engine speed and speed (automotive driving). In work mode, the speed is varied via the drive hydraulics at a constant engine speed.

Accelerator pedal	Effect
• Depress	• Engine speed, driving speed increases
• Release slowly	• Engine speed, driving speed is reduced, adjustment of the hydrostatic braking effect
• Release fully	• Maximum braking effect of the hydrostatic drive and the diesel engine



Attention

With hydraulic oil temperatures below 10 °C, the diesel speed is reduced by the drive control to prevent damage to the hydraulic pumps.



Attention

A sensor on the pressure filter limits the drive control when the pressure filter is soiled. The vehicle might no longer achieve maximum speed. The symbol **Fig. 76-A** appears in the multifunction display. Inform an authorised workshop.



Note

The maximum speed which can be reached depends on the speed level which has been selected with the driving mode tip switch.

Engine speed tip switch

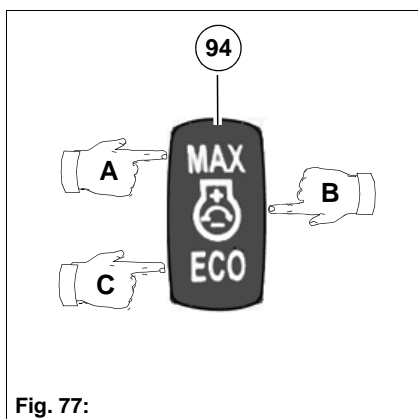

Fig. 77:

The desired engine speed for work mode is adjusted with the tip switch **Fig. 77-94**. Set the speed according to the requirements.

Stage	rpm	Use
1 - ECO	1400	Slight soiling or operation on flat ground. The brush and suction fan speeds are limited. When switching off ECO mode, the engine speed increases to 1700 rpm again.
2 - Standard	1700	Any soiling or operation on medium slopes
3 - Maximum	2000	Any soiling or operation on steep slopes



Note

ECO mode should not be actuated in winter service.

Differential lock (option)

The differential lock can be used when a rear axle wheel is spinning and it is not possible to drive on.

When the differential lock is switched on, the rigid connection of the drive shafts evenly transfers the driving torque to both rear axle wheels.



Attention

If the differential lock is switched on incorrectly, this may damage the rear axle differential. The differential lock can only be switched on if:

- the drive is not under load,
- the wheels are not spinning

Tip switch – differential lock

Switch on the rear axle differential lock using tip switch **Fig. 78-87**. The differential lock only remains active as long as the tip switch is pressed. When releasing the tip switch, the differential lock is deactivated. Engagement of the differential lock is indicated by the telltale lighting up in the tip switch.

Fig. 78:

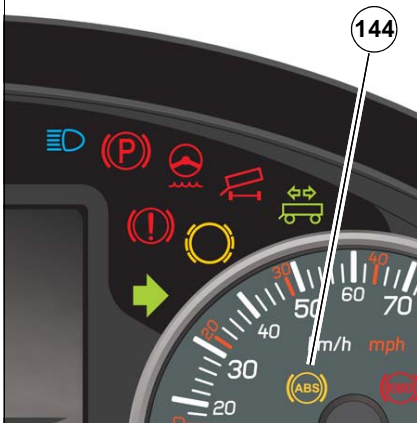
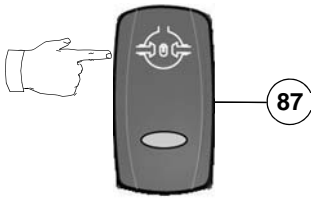

Differential lock

ON	<ul style="list-style-type: none"> • Press the tip switch on symbol. 	<ul style="list-style-type: none"> • Telltale in tip switch lights up
OFF	<ul style="list-style-type: none"> • Release the tip switch: 	<ul style="list-style-type: none"> • Telltale off



Note

When driving, the differential lock can be activated up to max. 25 km/h. The function only remains active as long as the tip switch differential lock is pressed. The differential lock only engages when low speed differences have occurred at the rear axle wheels (e.g. when cornering). The differential lock is switched off when the ignition is switched off. Driving on firm ground with activated differential lock increases tyre wear. Never use the differential lock for longer than necessary. Never switch on the differential lock when cornering on solid ground – this results in tyre wear and may damage the axles.



Note

ABS is switched off when the differential lock is active. The ABS light **Fig. 78-144** lights up and the symbol "brake special mode" **Fig. 78-A** is shown in the multifunction display. Adjust the driving style accordingly. In order to protect the powertrain when the differential lock is activated, the driving torque of the hydrostatic drive is limited.

3 Operation

3.1 General Notes

3.1.1 Instruction

Instruction is required before the first start-up. The first-time instruction of the vehicle may be provided only by a specialist of your authorised Hako dealer. This person will be notified immediately after delivery of the vehicle from the factory and will contact you to make an instruction appointment.

3.1.2 Running-in period

Handle the vehicle carefully during its first 100 operating hours.

Observing the following recommendations during the running-in period will create the conditions required for optimum performance and a long vehicle service life.

- Do not overload the vehicle, but do not drive too cautiously either, otherwise the vehicle will never reach its proper operating temperature
- Do not keep the engine running at maximum speed for extended periods
- Increase the load gradually whilst varying the engine speed
- Stick rigidly to the maintenance plans, see Maintenance plan.

3.2 Driving the Citymaster 2200

3.2.1 Before start-up of the vehicle

Safety instructions – Before start-up of the vehicle



Danger

- Always switch on the lights when visibility is poor and after dark. There is a risk of accidents!
- Good viewing conditions contributing to traffic safety are guaranteed only if all windows are free of ice, snow and condensation. There is a risk of accidents!
- Never change the seat position when driving. Adjust the seat before moving the vehicle. There is a risk of accidents!
- Driving with the head rest set incorrectly means risk of injury!
- Driving or working without the seat belt means risk of injury! The seat belt will be stretched after an accident, and can no longer be used. Therefore, in the event of another accident, this overstretched seat belt will not provide sufficient safety.
- There is a risk of accidents when adjusting the steering column when driving or while driving with the steering column unlocked.
- There is a risk of accidents when driving with open doors!
- There is a risk of accidents when driving with unadjusted outside rearview mirrors!
- Dirt accumulation in the area of the brake pedal can result in brake malfunctions. There is a risk of accidents!

Warning

- The vehicle must only be used when in technically perfect condition in accordance with its designated use and the instructions set out in the Operating Manual, and only by persons who are aware of the risks and safety factors involved. Rectify (or have rectified) any functional disorders immediately, especially those affecting the safety of the vehicle.
- Before starting work, the operator must familiarize himself with all equipment, operating and actuating elements as well as with their function. It is too late to do this during operation!
- Before starting work, familiarise yourself with the working environment at the work site. The working environment includes, for example, any obstacles in the working and traffic area, the load-bearing capacity of the ground, and any necessary barriers separating the work site from public roads.
- A warning triangle, a warning light, a warning vest and a first aid kit must be in the vehicle during operation.
- Sturdy and slip-proof shoes must be worn when working with the vehicle.
- Only use the footholds and handles provided when entering and leaving the cab!
- Never use the controls or mobile cables as handles!
- Never climb onto or jump off a moving vehicle!
- Passengers must only sit on the passenger seats provided for this purpose. Never carry persons on the tipper or on implements and attachments.
- Only those surfaces approved by the contractor or its authorised representative for use of the vehicle may be driven on.
- The vehicle is not suitable for removing dangerous, combustible or explosive liquids, dusts or materials.
- Observe the maximum gradability of the vehicle, see Technical data.

Checklist – Before start-up of the vehicle

Observe the Safety instructions – Before start-up of the vehicle, see page 108.

No.	Task	Page	✓
1	Checking the fuel supply	54	
2	Checking the AdBlue reserve	55	
3	Checking the engine oil level	186	
4	Checking the coolant level	193	
5	Checking the hydraulic oil level	198	
6	Checking the brake fluid level	203	
7	Checking the tyre condition and pressure	208	
8	Checking the windscreen washer unit	211	
9	Checking the electrical system (fuses, light bulbs, condition of the battery)	212	
10	Checking the battery master switch (option)	49	
11	Checking the light and signal system	76	
12	Adjusting the heating and ventilation	83	
13	Adjusting the driver's seat	87	
14	Adjusting the head rest (option)	88	
15	Checking the seat belt	90	
16	Adjusting the steering column	92	
17	Checking the outside mirrors	93	
18	Checking the brake pedal and parking brake	95	
19	Checking the steering	101	
19	When driving without front-mounted equipment, the hood of the coupling triangle must be fitted	124	

3.2.2 Starting the vehicle and moving off

Safety instructions – Starting the vehicle and moving off

	<p>Danger</p> <ul style="list-style-type: none"> • It is not permitted to stand underneath the dirt hopper if it is not secured. Always fit the safety strut whenever working underneath the dirt hopper. There is a danger to life! • Special caution is required in the area of the front and rear-mounted equipment and attachments. There is a danger to life! • Inhaling exhaust gases is injurious to health and can lead to unconsciousness and to death! Never let the engine run in enclosed spaces. Danger to life due to toxic engine exhaust gases. • Avoid sudden turns when driving uphill or downhill or across slopes. Danger to life due to the vehicle tipping over in an inclined position! The vehicle speed must always be adapted to the surrounding conditions and the load condition. • The power brake does not work when the engine is switched off or in the event of a brake circuit failure. The brake pedal has to be pressed much harder. Take this into account, especially when towing the vehicle. There is a risk of accidents! • Strong hydrostatic braking effect when abruptly changing direction. There is a risk of accidents! • Relying on the anti-blocking system (ABS) to shorten the braking distances should not lead to a careless driving style. It is primarily designed as a safety reserve in difficult situations. ABS is also not capable of overcoming physical limits. This must be taken into account, especially when the road is slippery or wet. There is a risk of accidents! • Note that there is a risk of skidding on unpaved ground or snow and ice. This can lead to uncontrolled behaviour of the vehicle. Drive correspondingly carefully! There is a risk of accidents! • Turning the steering wheel requires greater effort if the power steering fails – emergency steering. Take this into account, especially when towing the vehicle. There is a risk of accidents! • Switch over the steering type only when the vehicle is standing. There is a risk of accidents! <p>Warning</p> <ul style="list-style-type: none"> • For reasons of safety, the vehicle is equipped with a seat contact switch and the function of the seat contact switch must not be bypassed. • In the case of restricted vision, especially when reversing the vehicle, it is necessary to have a second person who gives the driver appropriate signals. The second person must always be in the field of view of the driver. • When working with the vehicle, pay special attention to third persons, especially children. • In transport journeys on public roads the working spotlights must be switched off. • When driving underneath underpasses, bridges, tunnels or overhead lines, always make sure that there is sufficient clearance. • Always maintain sufficient distance from the edges of building pits and slopes.
---	--

Checklist – Starting the vehicle and moving off

No.	Task	Page	✓
1	Check all items from the checklist – Before start-up of the vehicle	109	
2	In transport mode: Check the transport protection device at the front tool carrier In work mode: Check all items from the checklist – Before start-up of the vacuum sweeping system	124 141	
3	Start the vehicle	111	
4	Move off	113	

Starting the vehicle

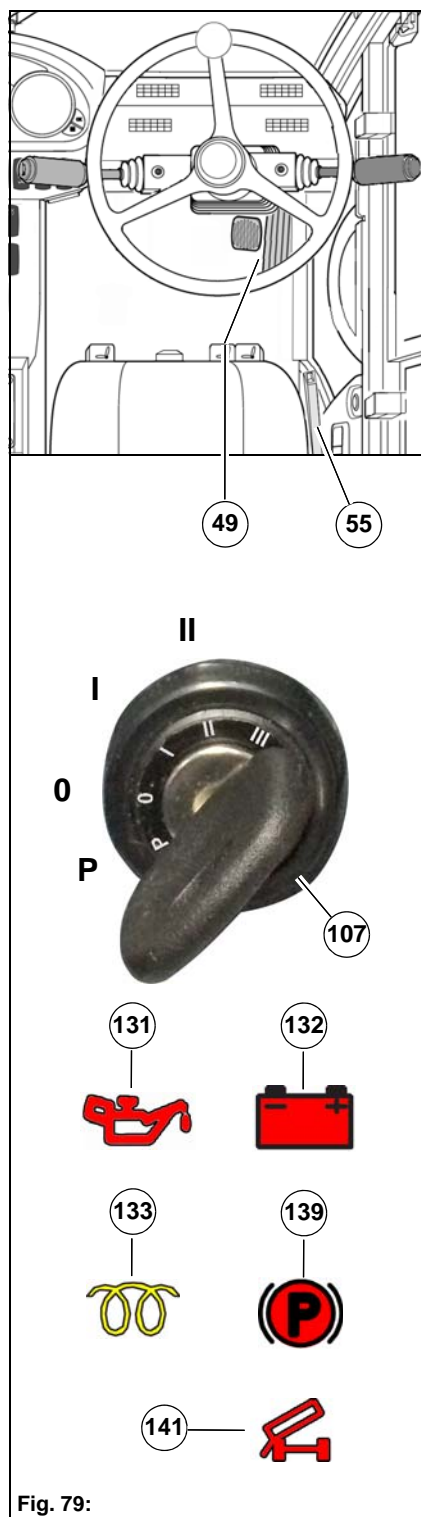

Fig. 79:

Observe the Safety instructions – Starting the vehicle and moving off, see page 110.

1. Insert ignition key into the ignition switch **Fig. 79-107**.
2. Turn the ignition key to position "I".
 - The warning lights **Fig. 79-131 and 132** light up.
 - The warning light **Fig. 79-139** lights up when parking brake **Fig. 79-** is applied.**55**
 - The telltale **Fig. 79-141** lights up when the attachment is raised or not fully lowered.
3. At low temperatures:
 - The engine is preheated until the telltale **Fig. 79-133** goes out. The engine must be started immediately after the telltale **Fig. 79-133** has gone out.
4. Do not actuate the accelerator pedal **Fig. 79-49** during the starting procedure.



Note

The starter cannot be actuated when the engine is already running (start repeat lock). Do not run the starter for more than 10 seconds. Wait for about 1 minute to let the battery recover before trying again.

5. Turn the ignition key to position "II" and hold it in this position until the engine starts.
6. Release the ignition key.



Note

The engine can only be started when battery master switch (option) is switched on, the driving switch is in the neutral position and accelerator pedal is not depressed.



Attention

Never let the vehicle roll when the diesel engine is not running. In this case,

- there is no power steering through the diesel engine.
- there is no brake servo through the diesel engine.
- hydraulic components of the hydrostatic drive may be damaged.

For information on recovering the vehicle in case of a breakdown, see see page 119.

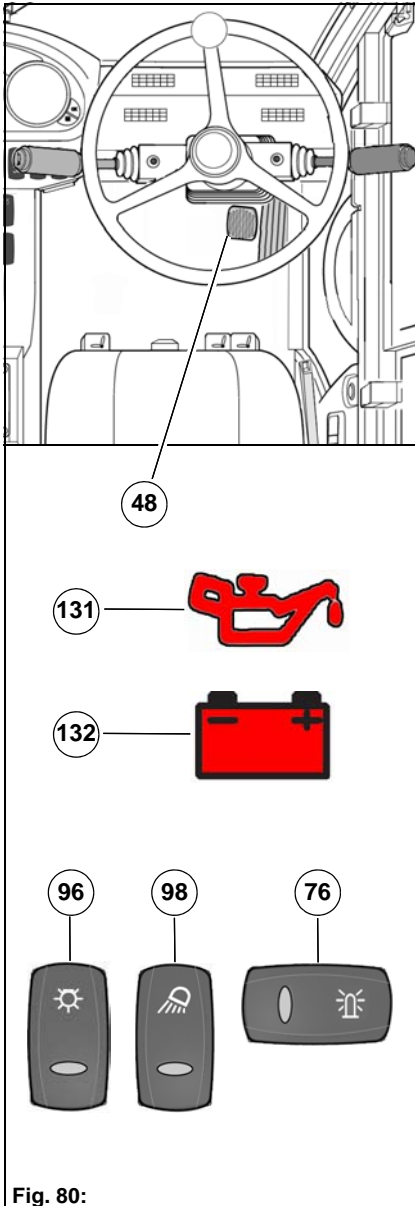

Fig. 80:

When the engine has started:

Check that the following warning lights have gone out:

- Warning light **Fig. 80-131**
If not, check the engine oil level.
- Warning light **Fig. 80-132**
If not, check connection between V-ribbed belt and alternator.
- Let the engine warm up.

Inspection of important functional units

- Steering: For the functional check, move the steering wheel to and fro. Check whether the wheels (depending on the steering mode) are moving.
- Service brake: Before moving off, depress the brake pedal **Fig. 80-48** and check whether
 - firm resistance can be felt on the pedal after a maximum of half the pedal travel and high foot power.
 - a maximum of approx. 2/3 of the total pedal travel (up to 3 cm before the stop) can be felt with the engine running and high foot pressure applied,
 - the brake lights light up when the brake pedal is depressed.
- Lighting: If required, switch on the low beam **Fig. 80-96**, working lights **Fig. 80-98** and rotating beacon **Fig. 80-76**.

In the cold season or after a longer standstill:

- Increase engine speed gradually.
- Only set off at full power when the engine has reached its operating temperature.



Attention

At hydraulic oil temperatures below 25 °C, the engine speed is limited by the drive control to prevent damage to the hydraulic pumps.



Note

In the cold season, use oil suitable for the temperature, see Operating materials and lubricants.

Special instructions for driving on public roads

The vehicle is subject to:

- The applicable legal regulations of your country
- The requirements specified in the general operation licence or the vehicle registration document.

In addition, bear in mind the mandatory regulations relevant to accident prevention.

Observe the relevant national regulations for your country.

Moving off

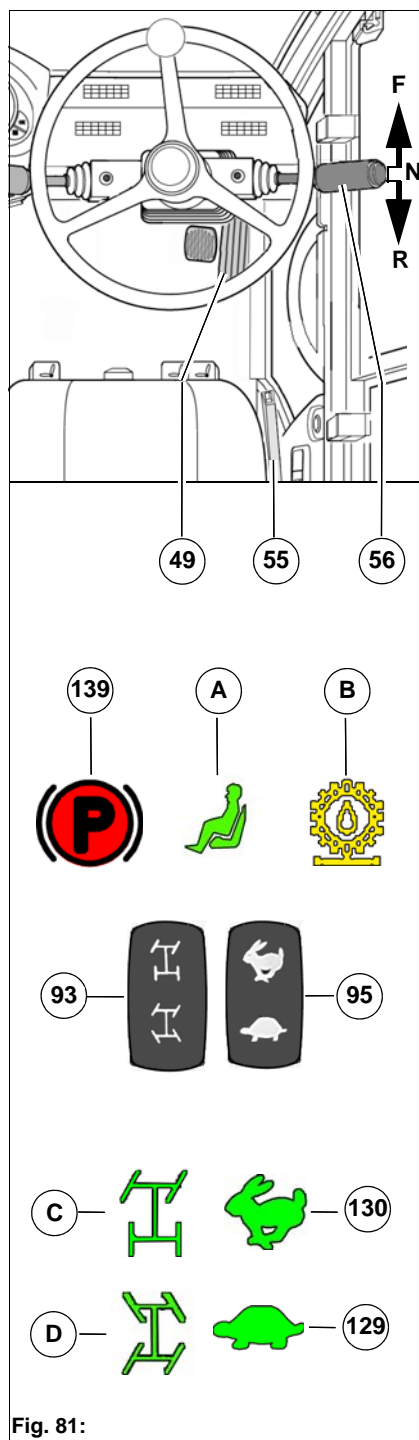

Fig. 81:

Observe the Safety instructions – Starting the vehicle and moving off, see page 110.

After starting the engine:



Attention

Make sure that the parking brake is released – driving with the parking brake applied overheats the parking brake and causes it to break.

1. Preselect the driving mode with the tip switch **Fig. 81-95**, see page 103. The respective symbol appears in the multifunction display:
 - Transport mode **Fig. 81-130**
 - Work mode **Fig. 81-129**
2. Preselect the steering mode with the tip switch **Fig. 81-93**, see page 100. The respective symbol appears in the multifunction display.
 - Front wheel steering **Fig. 81-C**
 - Four-wheel steering (only in work mode) **Fig. 81-D**
3. Preselect the driving direction with the switch **Fig. 81-56**.
4. Release the parking brake **Fig. 81-55**.
 - The warning light **Fig. 81-139** in the indicating device goes out.
5. Slowly apply the accelerator pedal **Fig. 81-49**.
6. Test the brakes when travelling at low speed. Check in the rearview mirror to ensure that a braking manoeuvre will not cause any kind of obstruction.
7. Always warm the engine up before running it under full load.



Note

If the driver is not on the driver's seat when the engine is running, the warning symbol **Fig. 81-A** appears in the multifunction display.



Attention

At hydraulic oil temperatures below 25 °C, the diesel speed is limited by the drive control to prevent damage to the hydraulic pumps.

If the pressure filter of the drive pump is contaminated, the warning symbol **Fig. 81-B** appears in the multifunction display. The drive pump no longer supplies the full delivery rate and the vehicle does not achieve maximum speed. Inform an authorised workshop.

Driving the vehicle

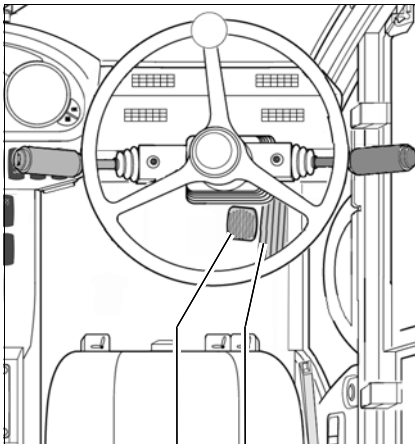

48 49



Fig. 82:

The driving speed can be adjusted steplessly using the accelerator pedal **Fig. 82-49**. Depending on the respective vehicle equipment, maximum speed on flat ground is achieved at an engine speed of between 2000 and 2300 rpm. This means that after completing the accelerating phase it is possible to release the accelerator pedal **Fig. 82-49** slightly while driving on flat ground without reducing the driving speed.

This actively contributes to reduced noise and reduced fuel consumption.

In order to achieve maximum acceleration or maximum speed when driving uphill, drive at full throttle so that the diesel engine works with nominal horsepower at approx. 2600 rpm.



Danger

With steep downhill travel and fully loaded vehicle, the braking effect of the hydrostatic brake alone is not enough to keep the vehicle speed constant. There is a risk of the diesel engine over-revving. When the diesel engine over-revs or the maximum speed is exceeded, an acoustic and a visual signal are output in the multifunction display.

Additionally brake the vehicle using the service brake **Fig. 82-48**.

An interlocking circuit is fitted to protect the drive hydraulics on the vehicle from overheating. If the temperature exceeds 80 °C, the interlocking circuit for drive hydraulics intervenes.

The symbol **Fig. 82-A** for the hydraulic oil temperature in the multifunction display lights up red at a temperature above 75 °C:

- A signal tone is output three times, and a warning symbol is displayed full-screen for five seconds in the multifunction display.
- Control of the hydrostatic drive reduces the driving speed to 25 km/h.

Once the hydraulic oil temperature has fallen below 80 °C, it is possible to drive at full speed again.

Driving on slippery roads

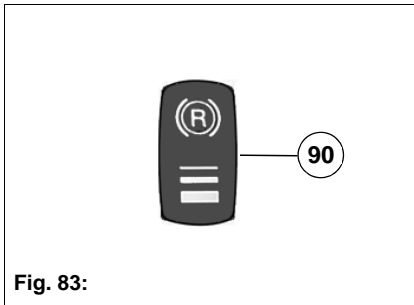

Fig. 83:

Driving in an anticipatory and defensive manner are particularly important when driving on wet roads and in wintry conditions.

Always adjust the driving speed to the road conditions and the load being carried. Pay particular attention to the axle loads and centre of gravity height. In case of a high centre of gravity of the attachment, avoid excessive speeds and erratic driving at all times.

Particularly with rear axle drive and a light rear axle, the hydrostatic braking effect must be set with the switch **Fig. 83-90** to ensure the rear axle is not overbraked, see page 117.



Attention

Observe the minimum rear axle loads for attached front-mounted equipment and trailer operation, see Technical data.

If overbraking nevertheless occurs due to the hydrostatic braking effect, the braking effect is reduced by the drive control. The vehicle is equipped with ABS of the service brake so that a sufficient braking effect is achieved even on slippery roads while retaining steering capability.

Depending on the size of the tyres, it is possible to drive with snow chains (option).

3.2.3 Stopping and parking the vehicle

Safety instructions – Stopping and parking the vehicle

	<p>Danger</p> <ul style="list-style-type: none"> • Only use the parking brake instead of the service brake in an emergency, i. e. if the service brake is out of operation. The brake lights will not light up in this case. There is a risk of accidents! • Adopt measures against erroneous starting and unwanted movement. There is a risk of accidents! • The vehicle must be parked on firm ground. On inclinations secure the vehicle additionally against rolling away with a wheel chock. There is a risk of accidents! • The diesel particle filter and the SCR catalytic converter get very hot. Risk of fire and burns! <ul style="list-style-type: none"> • Do not reach into the area of the exhaust outlet. Keep children and other persons away from this area. • When operating the vehicle, make sure that no easily inflammable materials are in the direct vicinity of the exhaust system, especially the exhaust pipe. • When parking the vehicle while the engine is running, make sure that no inflammable or combustible materials (e.g. paper, dry grass, straw, wood, wooden building materials, oil, fuels, etc.) are in the direct vicinity of the exhaust outlet. • Do not park the vehicle in high dry grass. Never use additional underbody sealant or anti-corrosive agents for exhaust pipes, heat shields or the diesel particle filter. These could ignite when the engine is hot.
---	--

Checklist – Stopping and parking the vehicle

No.	Task	Page	✓
1	No inflammable or combustible materials in the direct vicinity of the exhaust system		
2	Lower the front-mounted equipment to the ground or lock the transport protection device for road travel	124	
3	Apply parking brake	95	
3	Lock the vehicle cab; especially if the vehicle cannot be supervised	93	
3	When parking on uphill or downhill slopes: Additionally secure the vehicle with a wheel chock under one of the wheels to prevent it from rolling away	118	

Stopping the vehicle

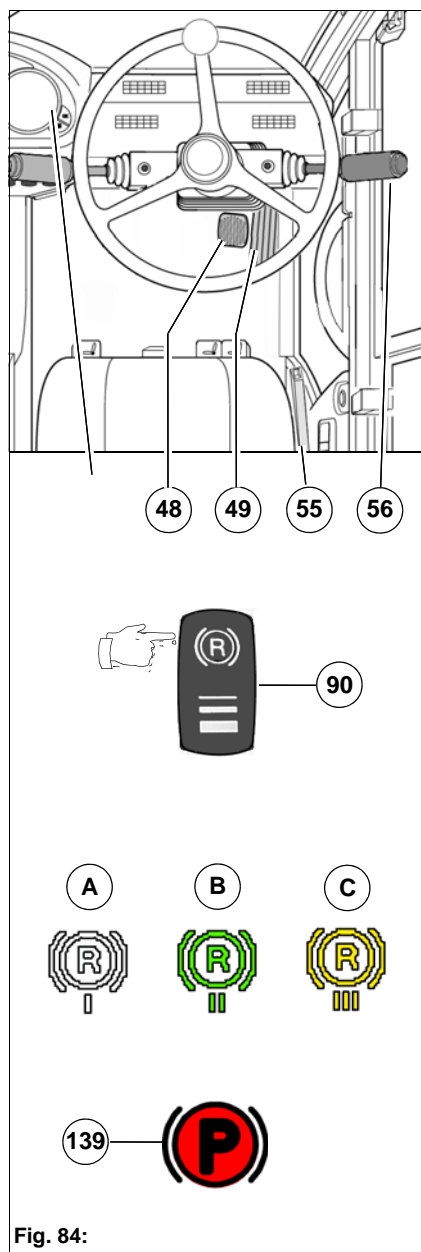

Fig. 84:

Braking with the drive

Observe the Safety instructions – Stopping and parking the vehicle, see page 116.

The hydraulic brake force can be adjusted with the switch **Fig. 84-90**. Press the switch according to the desired braking effect:

- Switch in stage I: slight braking effect
- Switch in stage II: medium braking effect
- Switch in stage III: strong braking effect

The respective symbol appears in the multifunction display.

- Stage I: Symbol **Fig. 84-A**
- Stage II: Symbol **Fig. 84-B**
- Stage III: Symbol **Fig. 84-C**

1. Press the switch **Fig. 84-90** according to the desired braking effect.
2. Remove your foot from the accelerator pedal **Fig. 84-49** or move the drive switch **Fig. 84-56** to the neutral position.
3. Gently press the brake pedal **Fig. 84-48**.



Note

When the vehicle is braked sharply with the hydrostatic drive or when the foot is abruptly removed from the accelerator pedal, the brake lights are switched on to warn the vehicles behind.

Braking with the brake pedal

Observe the Safety instructions – Stopping and parking the vehicle, see page 116.

1. Remove your foot from the accelerator pedal **Fig. 84-49**.
2. Press the brake pedal **Fig. 84-48** until the vehicle comes to a standstill.
3. Move the direction indicator switch **Fig. 84-56** to the neutral position.
4. Operate the parking brake **Fig. 84-55**.
 - The warning light **Fig. 84-139** in the indicating device lights up.

Parking the vehicle

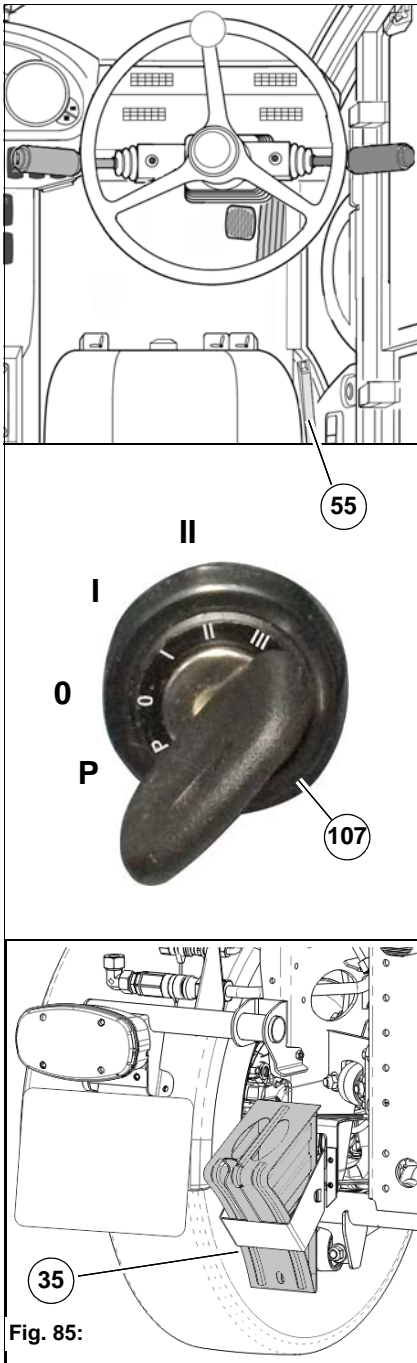

Fig. 85:

Parking the vehicle after the end of work

Observe the Safety instructions – Stopping and parking the vehicle, see page 116.

1. Brake the vehicle and secure it with the parking brake, see page 116. On inclinations secure the vehicle additionally against rolling away with a wheel chock **Fig. 85-35**, if necessary.
2. Turn the ignition key in the ignition switch **Fig. 85-107** to position "0" and remove it.
3. Lower the front-mounted equipment to the ground or lock the transport protection device for road travel.

Parking the vehicle after operation at full power

Observe the Safety instructions – Stopping and parking the vehicle, see page 116.

1. Allow the engine to run on for approx. 60 seconds so that the temperature can stabilise.
2. Turn the ignition key in the ignition switch **Fig. 85-107** to position "0" and remove it.
3. Lock the doors after leaving the vehicle cab.

Parking the vehicle after a fault

Observe the Safety instructions – Stopping and parking the vehicle, see page 116.

The engine must be switched off immediately on the occurrence of faults. A vehicle left lying on public roads must be secured with the hazard warning flasher and warning triangle. If the electrical system has failed, the vehicle must be secured with the warning light from the safety package (option). The warning triangle and hazard light are in the safety package (option).



3.2.4 Recovering and transporting the vehicle

The vehicle is equipped with a hydrostatic drive. With this drive concept, the combustion engine and the subsequent power transmitting drive hydraulics are always engaged and cannot be separated via idle speed as is the case with a vehicle with selector gearbox.

Towing over longer distances with a towing vehicle, especially when the diesel engine is switched off, results in damage to the hydraulic components of the hydrostatic drive.

For this reason, towing is not possible and not intended. The damaged vehicle must be recovered on a transport trailer or on a transport vehicle.

Safety instructions – Recovering and transporting the vehicle

	<p>Danger</p> <ul style="list-style-type: none"> • Start driving slowly! Make sure that there are no persons in the towing area. There is a danger to life! • The vehicle may be loaded only using suitable loading aids, such as a loading ramp or drive-up planks. There is a risk of injury! • After loading, make sure that the vehicle is secured according to regulations against rolling off and tilting. There is a risk of injury! Use the wheels for securing the vehicle. • If the diesel engine is switched off, power steering does not work – emergency steering function. Steering will then require more force. There is a risk of accidents! • The power brakes do not work when the engine is switched off. The brake pedal has to be pressed much harder. Take this into account, especially when towing the vehicle. There is a risk of accidents! <p>Warning</p> <ul style="list-style-type: none"> • Always recover the damaged vehicle rearwards! There are no suitable fixing points at the front of the vehicle. • The vehicle must only be recovered using suitable equipment (ropes or bars) in conjunction with suitable fixing points, such as a couplings, hooks and eyes. • The vehicle can be recovered using a rope when the service brake and the steering system are still fully functional. • Observe the permissible maximum distances and speeds during recovery!
	<p>Danger</p> <ul style="list-style-type: none"> • Remove any mud, snow and ice from the tyres so that the vehicle can be driven safely onto the ramps. There is a risk of injury! <p>Warning</p> <ul style="list-style-type: none"> • The transport vehicle must be of adequate size. Refer to the "Technical data" section for the dimensions and weights of the vehicle. • The vehicle may be loaded only using suitable loading ramps or drive-up planks. • Secure the vehicle against unintentional movement on the transport vehicle!

Recovering the vehicle

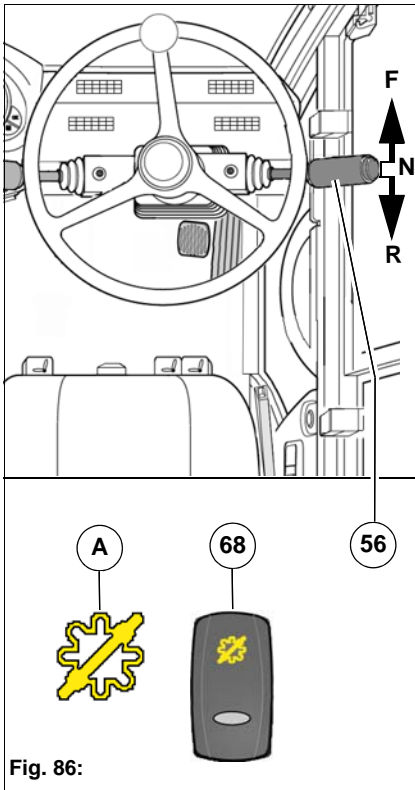

Fig. 86:

Observe the Safety instructions – Recovering the vehicle in case of a breakdown, see page 119.

During recovery, the vehicle can be moved via an external force over the following maximum distances at the following maximum speeds:

- When the diesel engine is running, max. 5 km at max. 10 km/h
- When the diesel engine is not running, max. 200 m at max. 2 km/h

Proceed as follows to recover the vehicle:

1. Switch off the attachment drives.
2. Move the attachments to the transport position and secure them.
3. Move the direction indicator switch **Fig. 86-56** to the neutral position.
4. Activate the front wheel steering.
5. Switch off the ignition.
6. In order to recover the vehicle, the recovery switch **Fig. 86-68** must be actuated. The telltale in the switch lights up. The yellow symbol **Fig. 86-A** appears in the multifunction display. The accelerator pedal is without function.
7. Recovery must always be carried out rearwards! Attach suitable recovery equipment to the vehicle frame.
8. In recovery mode, switch on the ignition and start the diesel engine if still possible.

Transporting the vehicle

Observe the Safety instructions – Transporting the vehicle, see page 119. After loading the vehicle, secure it against unintentional movement on the transport vehicle as follows:

- Apply the parking brake
- Use tension belts over the tyres or
- Use two lashing points at the front **Fig. 86-A** and two lashing points at the rear **Fig. 86-B**

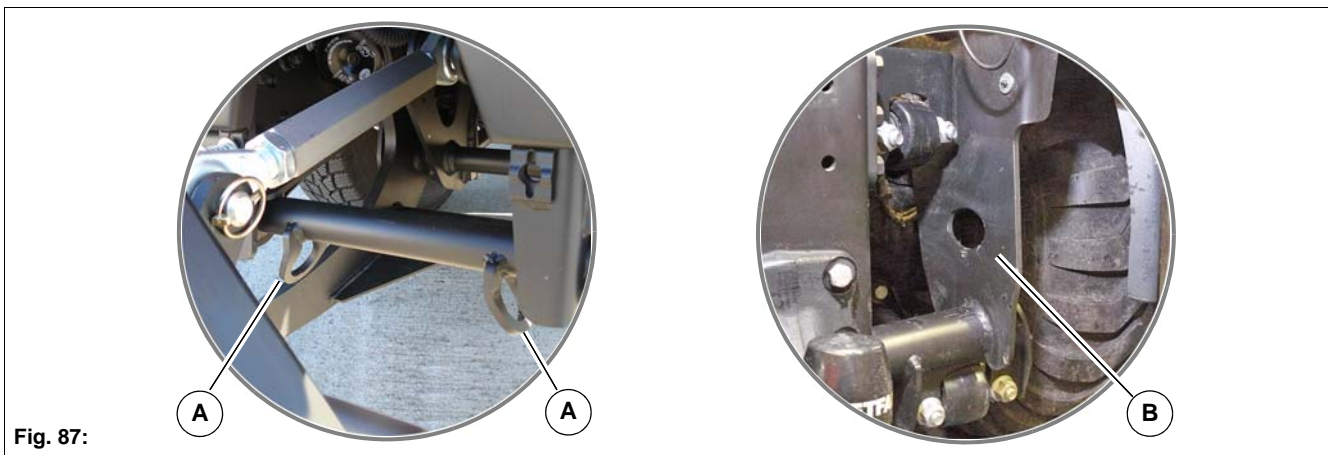



Fig. 87:

3.3 Attachments in general

Safety instructions – Attachments in general

	<p>Danger</p> <ul style="list-style-type: none"> • It is not permitted to stand underneath the dirt hopper if it is not secured. Always fit the safety strut whenever working underneath the dirt hopper. There is a danger to life! • Special caution is required in the area of the front and rear-mounted equipment and attachments. There is a danger to life! • You must consult Hako before attaching other attachments not approved by Hako! Check in the individual case that the relevant axle loads and total weights are complied with. There is a risk of accidents! • Put the attachment into service only if all protective devices are attached and in protection position. There is a risk of injury! • Make sure that the attachments are suitable for the set oil volume. An oil volume set too high can lead to injuries due to a defect of the attachment! There is a risk of injury! • Pressure hoses, fittings and couplings are important for equipment safety. Use only pressure hoses, fittings and couplings recommended by the manufacturer. There is a risk of injury! • When connecting attachments to the hydraulic system, ensure that the hydraulic hoses are connected correctly. Swapping the connections can lead to reverse functioning of the attachment, e.g. movement to the right rather than the left. There is a risk of injury! • Front attachments not correctly fastened to the front tool carrier can drop down while driving. Always secure the front attachment with the locking devices. There is a risk of accidents! • Handling, steering and braking as well as stability are influenced by attachments, trailers and the vehicle payload (e.g. full dirt hopper). For this reason, pay attention to adequate steering and braking capability as well as stability. There is a risk of accidents! • In Germany, if attachments extend beyond the outer lighting equipment of the vehicle or if the maximum distances of the outer lighting equipment specified according to StVZO are exceeded, the lighting equipment of the vehicle must be repeated (see information leaflet StVZO § 30, explanations 11 and 12). There is a risk of accidents! <p>Attention</p> <ul style="list-style-type: none"> • Observe the operating manual for the attachment.
---	--

3.3.1 Ballast

If the attachments are particularly heavy, it may be necessary to place ballasts on the vehicle. Observe the permissible axle loads or minimum axle loads.

	<p>Danger</p> <ul style="list-style-type: none"> • When attaching other attachments not approved by Hako, consult Hako as to whether the relevant axle loads and total weights are complied with! There is a risk of accidents! • The attachment of front and rear attachments must not lead to exceeding the permissible total weight, the permissible axle load and the tyre load capacity of the working machine! There is a risk of accidents! <p>Attention</p> <ul style="list-style-type: none"> • Make sure before purchasing the attachment that these requirements are fulfilled by weighing the working machine attachment combination!
---	--

3.3.2 Fitting the front-mounted equipment

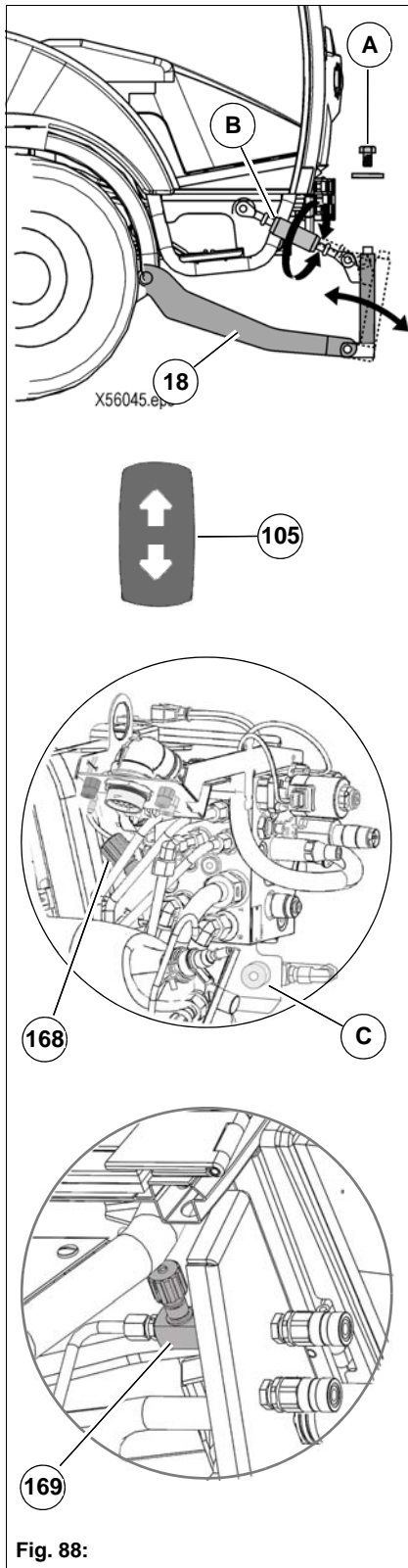

Fig. 88:

Observe the Safety instructions – Attachments in general, see page 121.



Note

Attachments can only be fitted to the Citymaster 2200 with the winter service option. Two possibilities are available:

- The suction mouth remains in the vehicle. In this case, the front tool carrier and thus also the suction mouth are raised and locked in the top position. The raise and lower function of the front-mounted equipment is then realised via an external lifting device (option).
- The suction mouth is removed. The raise and lower function of the front-mounted equipment is then realised via the front tool carrier.

1. Lower the front tool carrier **Fig. 88-18** with the tip switch **Fig. 88-105** and secure the vehicle against rolling away.
2. Remove the hexagon bolt and the washer **Fig. 88-A** of the front tool carrier.
3. If necessary, slightly tilt the front tool carrier forwards with the upper link **Fig. 88-B**.
4. Drive slowly and straight ahead with the front tool carrier underneath the bracket for the attachment.
5. Slowly raise the front tool carrier with the tip switch **Fig. 88-105**.
6. When raising the front tool carrier, make sure that it sits correctly in the bracket for the attachment.
7. Install the hexagon bolt and the washer **Fig. 88-A** to secure the front tool carrier.
8. If fitted, remove the outrigger supports of the front-mounted equipment.
9. Make the connections.

Adjusting the lowering speed of the front tool carrier or the external lifting device (option)

- The suction mouth has been removed (with 2-brush system):
The lowering speed of the front tool carrier is adjusted using the throttle valve **Fig. 88-168**. The throttle valve is located behind the cab on the right-hand side.
- The suction mouth has been removed (with 3-brush system):
The lowering speed of the front tool carrier is adjusted using the throttle valve **Fig. 88-C**. The throttle valve is located behind the cab on the right-hand side.
- The suction mouth remains in the vehicle and an external lifting device (option) has been fitted:
The lowering speed of the external front tool carrier is adjusted using the throttle valve **Fig. 88-169**. The throttle valve is located under the cab on the right-hand side. The suction mouth must be locked in the top position using the throttle valve **Fig. 88-168** or the throttle valve **Fig. 88-C**.

Making the connections for the front-mounted equipment

Observe the Safety instructions – Attachments in general, see page 121.



Note

Depressurise the hydraulic connections first before connecting the hydraulic hoses.

1. Turn on the ignition (do not start the engine!).
2. Actuate the respective control, the joystick **Fig. 89-112, 113 or 114** several times for front-mounted equipment.
3. Make the connections.
 - Connection **Fig. 89-153** for raising external lifting device, sleeve (red) (option)
 - Connection **Fig. 89-154** for lowering external lifting device, sleeve (red) (option)
 - Return **Fig. 89-155** rotatory main consumer, sleeve (red)
 - Pressure connection **Fig. 89-156** rotatory main consumer (front sweeping roller), sleeve (red) (option)
 - 23-pin socket **Fig. 89-159** for coding plug of the front-mounted equipment. Is only required for winter service when using a rotatory main consumer. (Sleeve **Fig. 89-155** and sleeve **Fig. 89-156**)
 - Front-mounted equipment with load sensing hydraulics for rotatory consumer: Sleeve (red) **Fig. 89-155** and sleeve (blue) **Fig. 89-160** and LS connection plug (blue) **Fig. 89-161**
 - Front-mounted equipment Swivel to the right sleeve (green) **Fig. 89-162** and front-mounted equipment Swivel to the left sleeve (green) **Fig. 89-163**. (e.g. swivel function, snow blade or rotary snow brush)

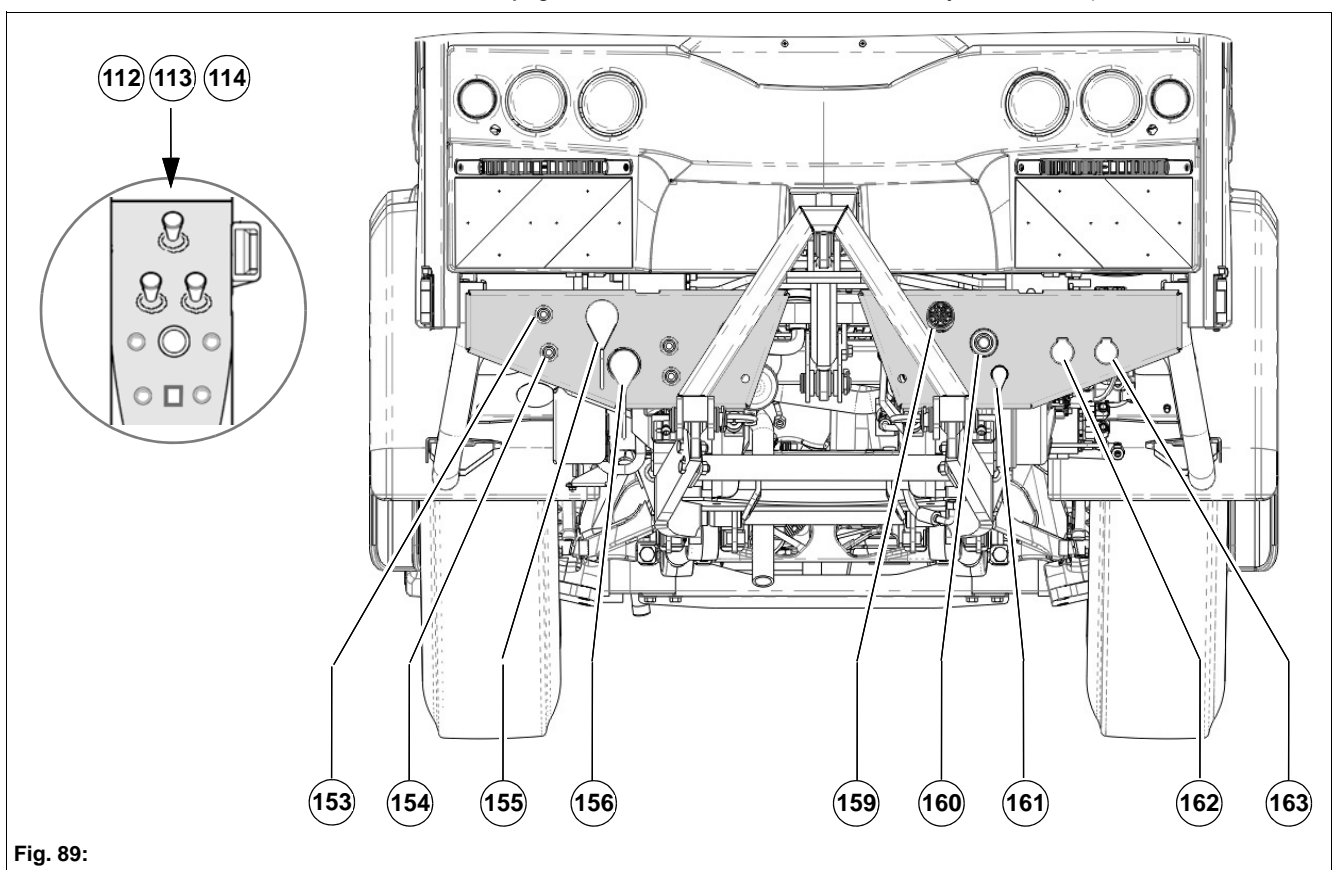

Fig. 89:

Checking the transport protection device

For longer transport journeys, the front-mounted equipment can be secured with the transport protection device **Fig. 90-A**.

Longer transport journeys

Move the front tool carrier **Fig. 90-18** to the upper end position. Remove the mounting bolts **Fig. 90-A** from the mounting holes **Fig. 90-C** and insert into the mounting holes **Fig. 90-B**.

Work mode / Offset mode

When the front tool carrier is in the upper end position, remove the mounting bolts **Fig. 90-A** from the mounting holes **Fig. 90-B** and insert into the mounting holes **Fig. 90-C**.

Removing the mounting bolts

Slightly press in the mounting bolts, turn 90° (vertically) and remove.

Inserting the mounting bolts

Insert the mounting bolts in vertical position, slightly press in and turn 90° (horizontally).

Coupling triangle hood



Attention

When driving without front-mounted equipment, the hood **Fig. 90-A** of the coupling triangle must be fitted.

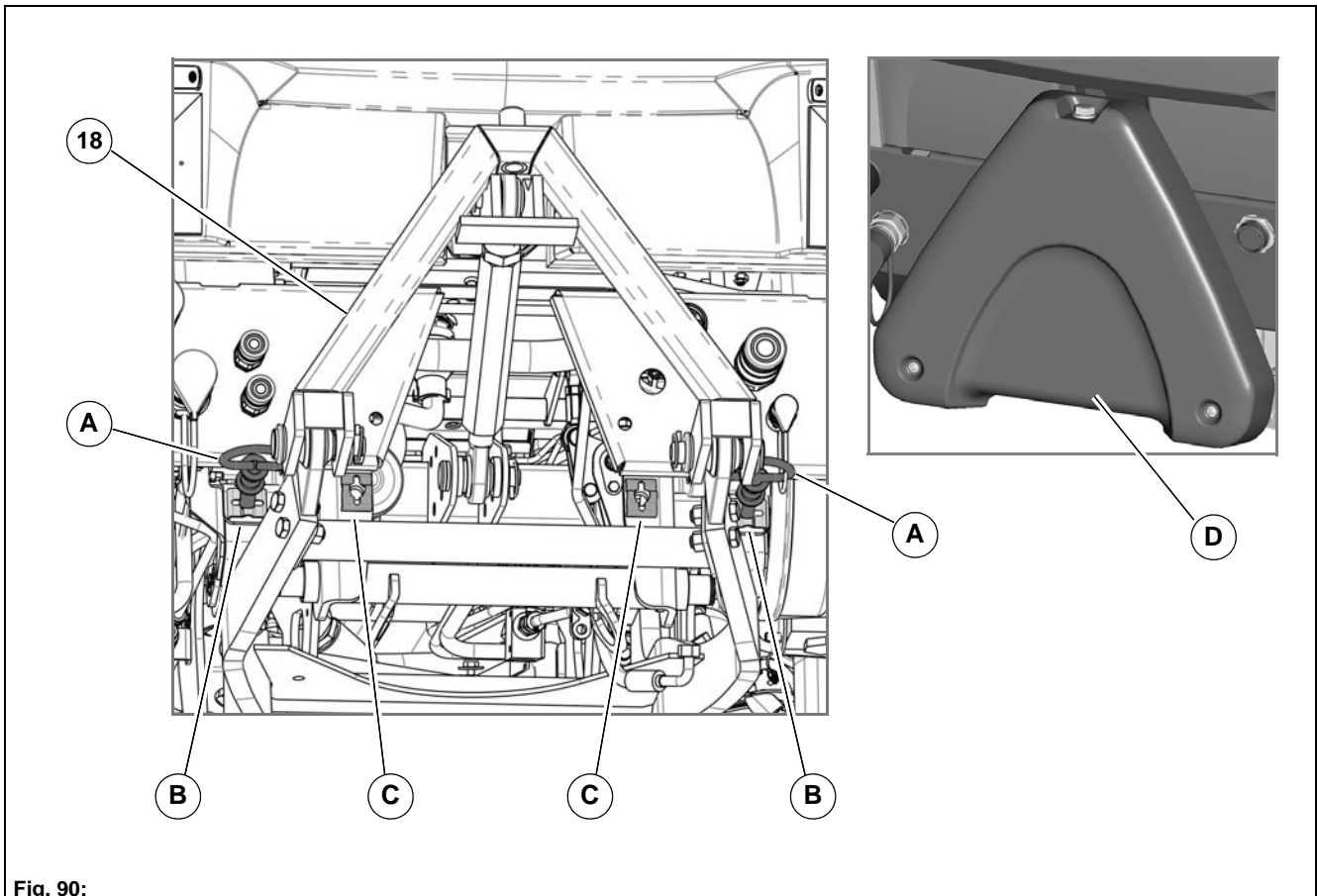

Fig. 90:

3.3.3 Operating the front-mounted equipment

Starting operation

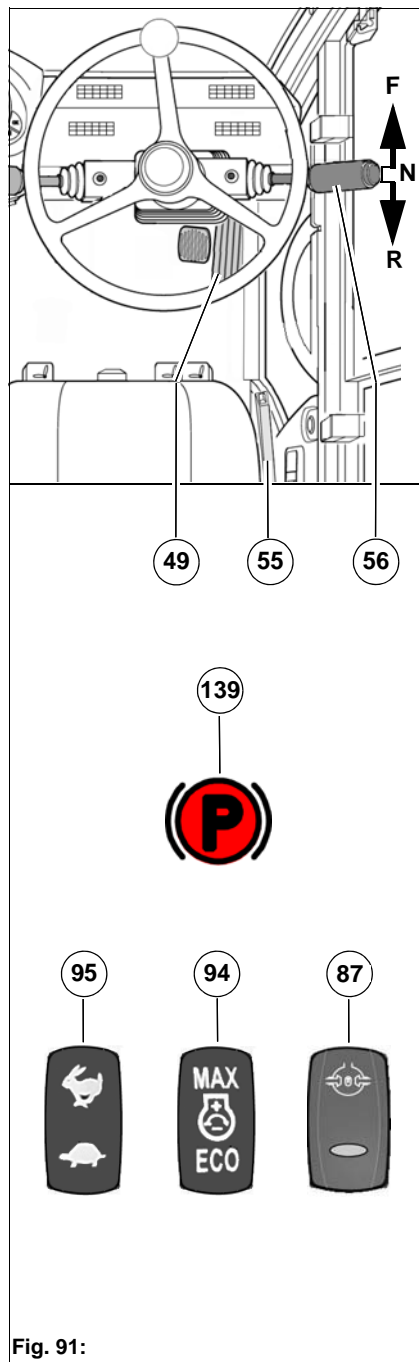



Fig. 91:

Observe the Safety instructions – Attachments in general, see page 121.

1. Switch on the work mode with the tip switch **Fig. 112-95**.

	<p>Note With a coded attachment, the respective function is activated automatically with the tip switch Fig. 112-95.</p>
---	--

2. Preselect the driving direction with the drive switch **Fig. 112-56** on the steering column.
3. Release the parking brake **Fig. 112-55**.
 - The warning light **Fig. 112-139** in the indicating device goes out.
4. Slowly apply the accelerator pedal **Fig. 112-49**.
 - The driving speed in work mode is 0 to 15 km/h.
5. The desired engine speed for work mode is adjusted with the tip switch **Fig. 112-94**. Set the speed according to the requirements.

Stage	rpm	Use
1 - ECO	1400	Slight soiling or operation on flat ground Volume flow: max. 80 litres/min
2 - Standard	1700	Any soiling or operation on medium slopes Volume flow: max. 100 litres/min
3 - Maximum	2000	Any soiling or operation on steep slopes Volume flow: max. 110 litres/min

6. Switch on the differential lock with the tip switch **Fig. 112-87**: The differential lock can be used when a rear axle wheel is spinning and it is not possible to drive on. For further information on the differential lock, see page 106

Front tool carrier

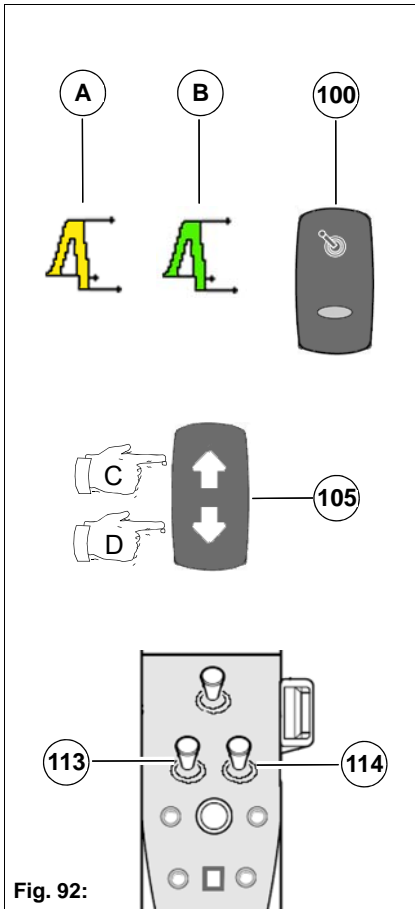

Fig. 92:

The front-mounted equipment can be raised or lowered with the tip switch **Fig. 92-105** for the front tool carrier.

- Raise: Press the tip switch on symbol **Fig. 92-C**.
 - If the front tool carrier is not raised for a transport journey, the yellow symbol **Fig. 111-A** appears in the multifunction display.
- Lower: Press the tip switch on symbol **Fig. 92-D**.
 - The front tool carrier is lowered to floating position.
 - The green symbol **Fig. 92-B** appears in the multifunction display.

Rapid winter service (option)

With the "rapid winter service" option, the front tool carrier can also be lowered in transport mode. Winter service up to 62 km/h can thus be performed. If the "rapid winter service" option is not available, the front tool carrier must be raised in transport mode. Winter service (clearing snow) can then only be performed in work mode (20 km/h). The same applies to the variant "raise/lower using external lifting device". Lowering of the front-mounted equipment via the front tool carrier or the external lifting device in transport mode is not possible if "rapid winter service" is not available and switched on. "Rapid winter service" is activated/deactivated by pressing the tip switch **Fig. 92-100**.

Swivel function

Swivelling the snow blade (option) or a rotary snow brush (option) is activated by moving the left-hand joystick **Fig. 92-113** to the side.

If a wedge snowplough is fitted, the left and right-hand side of the plough is swivelled by moving the left joystick **Fig. 92-113** and the right joystick **Fig. 92-114** to the side respectively.

Main consumer front-mounted equipment

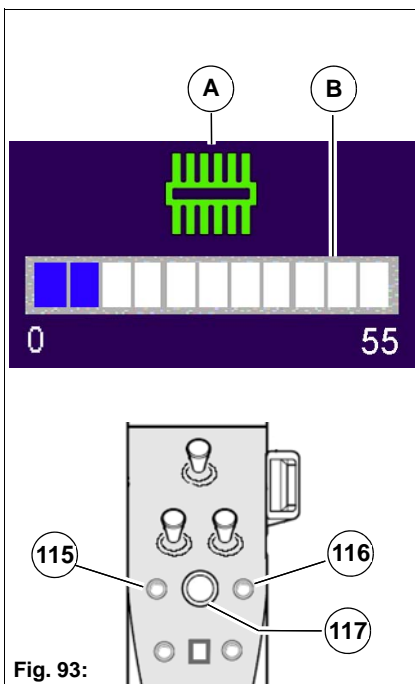

Fig. 93:

- Briefly pressing the quick select buttons **Fig. 93-115** or **Fig. 93-116** switches the main consumer on/off and opens the adjustment menu **Fig. 93-A** of the main consumer.
- Rotating the turn-push knob **Fig. 93-117** changes the value of the bar chart **Fig. 93-B**. One bar corresponds to 5 l/min and is divided into 4 increments (1.25 l/min). The maximum position corresponds to 55 l/min.
- Pressing the quick select buttons for longer (>1 s) opens only the adjustment menu without changing the activation status of the main consumer.
- The adjustment menu can be closed by pressing the turn-push knob **Fig. 93-117** for longer and closes automatically after 5 s without input.



Note

Initial brief actuation of the tip switches **Fig. 93-115** or **Fig. 93-116** after starting the vehicle does not directly activate the main consumers, but only opens the adjustment menu so that the driver can check the volume flow before activating the main consumer.

Additional functions of the front-mounted equipment

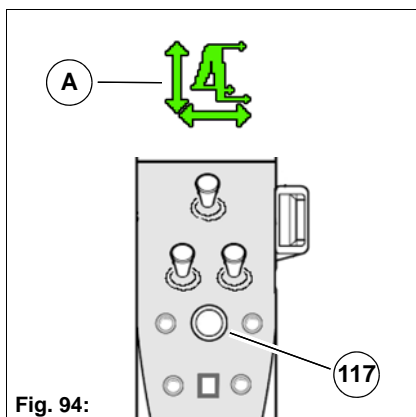

Fig. 94:

Area clearing function

The area clearing function facilitates the clearing of larger areas (e.g. a car park). When engaging reverse gear, the front-mounted equipment is raised automatically. When changing to a forward gear, it is lowered again.



Attention

Prior to each equipment change, always deactivate the area clearing function as otherwise the risk of accidents or damage increases.

Select the area clearing function:

- In work mode, press the turn-push knob **Fig. 94-117** for more than 2 seconds.
 - The selection menu appears.
- It is possible to toggle between the additional functions by rotating the turn-push knob. The arrows indicate that further additional functions are available.
- The additional function is activated or deactivated by pressing the turn-push knob.
 - The yellow frame around the symbol **Fig. 94-A** indicates the current activation status.

Front-mounted equipment automatic system

The front-mounted equipment automatic system is an interlocking circuit that can be activated. When raising the front-mounted equipment, the main consumer is switched off automatically. When lowering the device again, the main consumer is switched on automatically. This is only sensible for a rotary main consumer (e.g. a rotary snow brush).



Attention

Prior to each equipment change, always deactivate the front-mounted equipment automatic system as otherwise the risk of accidents or damage increases.

Select the front-mounted equipment automatic system:

- In work mode, press the turn-push knob **Fig. 95-117** for more than 2 seconds.
 - The selection menu appears.
- It is possible to toggle between the additional functions by rotating the turn-push knob. The arrows indicate that further additional functions are available.
- The additional function is activated or deactivated by pressing the turn-push knob.
 - The yellow frame around the symbol **Fig. 95-A** indicates the current activation status.

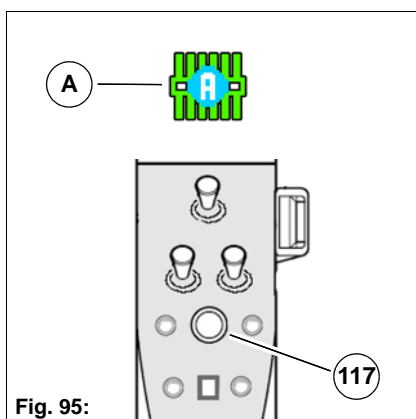



Fig. 95:

3.3.4 Fitting the attachment

Observe the Safety instructions – Attachments in general, see page 121. Before fitting a permanently installed attachment, switch off the lifting cylinder **Fig. 96-A** with the interlock switch **Fig. 96-66**. The interlock switch **Fig. 96-66** is located underneath the cover below the right fuse box.

	<p>Attention</p> <p>When the interlock switch Fig. 96-66 is switched off, unintentional actuation of the lifting cylinder Fig. 96-A of the tipper is prevented. If the lifting cylinder is tilted unintentionally, the attachment may be damaged.</p>
---	--

Making the connections for the attachment

Depressurise the hydraulic connections first before connecting the hydraulic hoses.

1. Turn on the ignition (do not start the engine!).
2. For attachments, press the switch **Fig. 96-65** for the pressure relief of the rear hydraulic connections.
3. Make the connections.
 - Attachment with a rotary consumer: Plug **Fig. 96-171** and sleeve **Fig. 96-172**
 - Attachment swivel function: Sleeve **Fig. 96-173** and sleeve **Fig. 96-174**
 - 13-pin socket **Fig. 96-175** for clearance lights

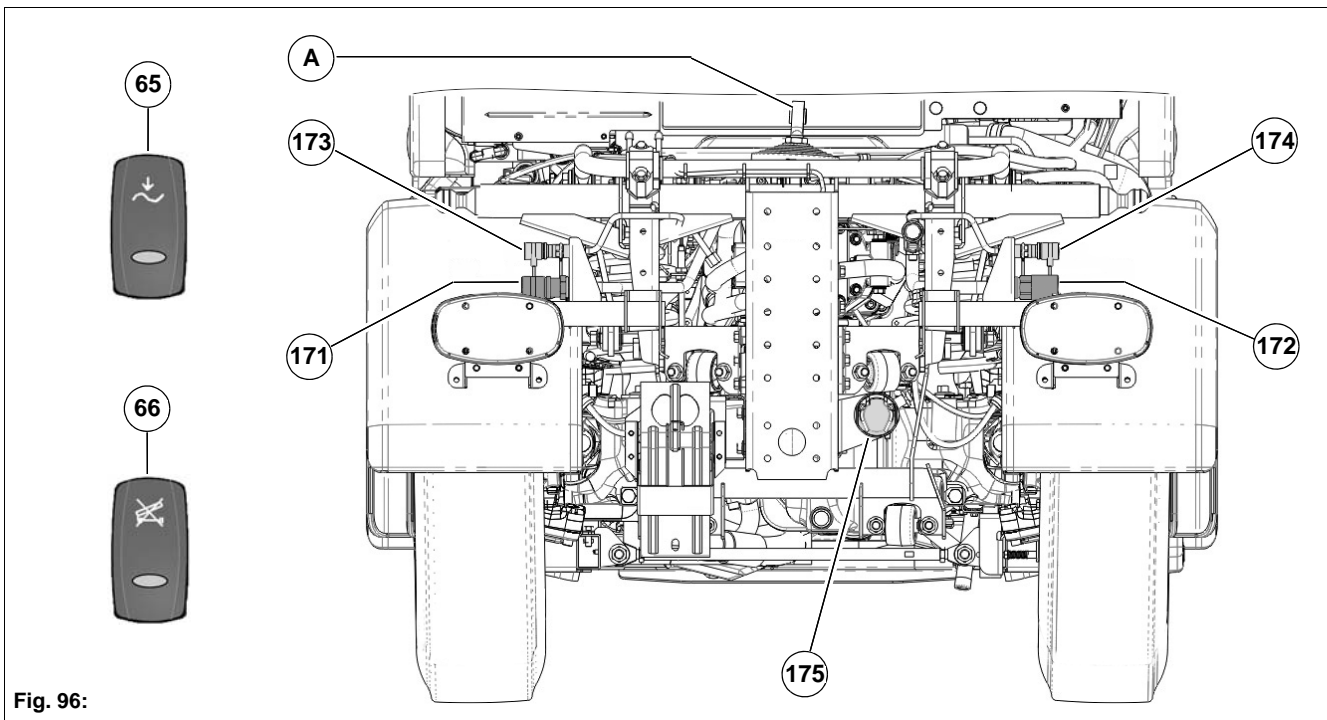

Fig. 96:

3.3.5 Operating the attachment

Observe the Safety instructions – Attachments in general, see page 121.

Main consumer of the attachment

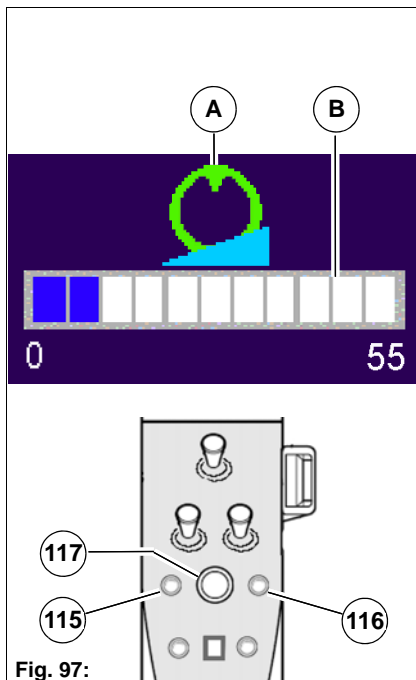

Fig. 97:

- Briefly pressing the quick select buttons **Fig. 93-115** or **Fig. 93-116** switches the main consumer on/off and opens the adjustment menu **Fig. 93-A** of the main consumer.
- Rotating the turn-push knob **Fig. 93-117** changes the value of the bar chart **Fig. 93-B**. One bar corresponds to 5 l/min and is divided into 4 increments (1.25 l/min). The maximum position corresponds to 55 l/min.
- Pressing the quick select buttons for longer (>1 s) opens only the adjustment menu without changing the activation status of the main consumer.
- The adjustment menu can be closed by pressing the turn-push knob **Fig. 93-117** for longer and closes automatically after 5 s without input.



Note

Initial brief actuation of the quick select buttons **Fig. 93-115** or **Fig. 93-116** after starting the vehicle does not directly activate the main consumers, but only opens the adjustment menu so that the driver can check the volume flow before activating the main consumer.

Additional function of the attachment

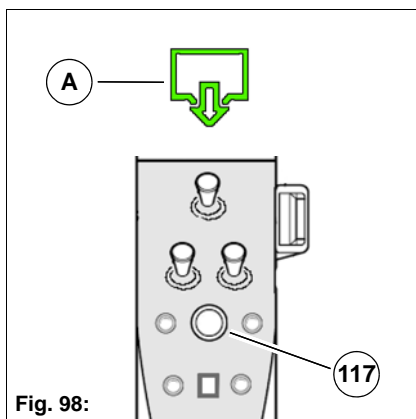

Fig. 98:

Quick emptying

A quick emptying option is available for changing the spreading material or cleaning the attachment.

Select quick emptying:

- In work mode, press the turn-push knob **Fig. 98-117** for more than 2 seconds.
 - The selection menu appears.
- It is possible to toggle between the additional functions by rotating the turn-push knob. The arrows indicate that further additional functions are available.
- The additional function is activated or deactivated by pressing the turn-push knob.
 - The yellow frame around the symbol **Fig. 98-A** indicates the current activation status.

3.4 Vacuum sweeping system

Safety instructions – Vacuum sweeping system



Danger

- It is not permitted to stand underneath the dirt hopper if it is not secured. Always fit the safety strut whenever working underneath the dirt hopper. There is a danger to life!
- Special caution is required in the area of the front and rear-mounted equipment and attachments. There is a danger to life!
- Avoid sudden turns when driving uphill or downhill or across slopes. Danger to life due to the vehicle tipping over in an inclined position! The vehicle speed must always be adapted to the surrounding conditions and the load condition.
- Make transport journeys only with a raised sweeping unit and with a completely lowered dirt hopper. There is a risk of accidents!
- The stability of the vehicle is influenced by a filled dirt hopper. Handling of the vehicle must be adapted accordingly. There is a risk of accidents!
- Do not exceed the permissible total weight of the vehicle! There is a risk of accidents!
- When the dirt hopper is emptied, the Citymaster 2200 must be on a sufficiently load bearing, horizontal surface. Driving with the dirt hopper tilted is not permitted. There is a risk of accidents!
- The jet of the high-pressure cleaner (option) must not be directed to persons. There is a risk of injury!

Caution

- The vacuum sweeping system may be operated only in connection with the Citymaster 2200. The safety regulations for the Citymaster 2200 must be complied with absolutely.

Attention

- When removing blockages in the suction hose or attaching the hand suction hose (option), switch off the engine and wait for the suction fan to come to a standstill.
- The vacuum sweeping system must be cleaned at least once a day, or more often in case of heavy soiling.
- Do not use steam cleaners and high-pressure cleaners (option) for cleaning electrical/electronic components and the engine compartment!

3.4.1 Mounting the suction mouth (2-brush system)

Observe the Safety instructions – Vacuum sweeping system, see page 130.

1. Place the vehicle on a level surface and hold it with the parking brake.
2. Raise the front tool carrier with the tip switch **Fig. 99-105**.
3. Push the suction mouth **Fig. 99-A** centrally under the lift system **Fig. 99-B**.
4. Align the jacking points **Fig. 99-C** of the suction mouth to the arm **Fig. 99-D** and the swivel head **Fig. 99-E** of the lift system.
5. Mount the suction mouth to the lift system using bolts, washers and nuts.
6. Attach the rubber buffers **Fig. 99-F** to the connecting plate of the front tool carrier **Fig. 99-K**.
7. Make the connections.
 - Slightly grease the suction hose **Fig. 99-G** and attach it to the suction duct.
 - Connect the hydraulic hose **Fig. 99-H** for the coarse material flap.
 - Attach the circulating water hose **Fig. 99-I** to the suction duct.
 - Attach the fresh water hose **Fig. 99-J** to the suction duct.

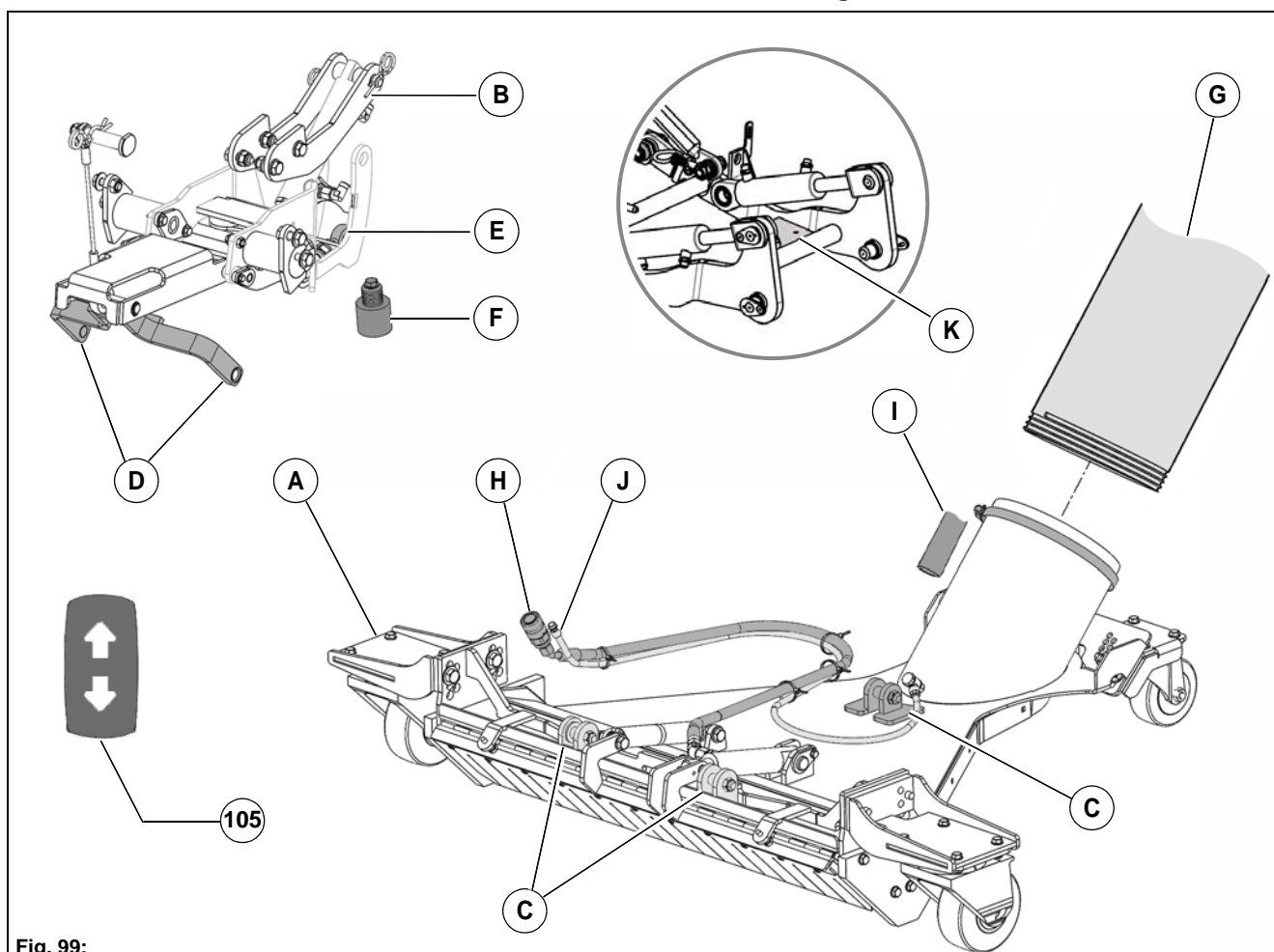

Fig. 99:

3.4.2 Mounting the suction mouth (3-brush system)

Observe the Safety instructions – Vacuum sweeping system, see page 130.

1. Place the vehicle on a level surface and hold it with the parking brake.
2. Raise the front tool carrier with the tip switch **Fig. 100-105**.
3. Push the suction mouth **Fig. 100-A** centrally under the lift system **Fig. 100-B**.
4. Align the jacking points **Fig. 100-C** of the suction mouth to the arm **Fig. 100-D** and the swivel head **Fig. 100-E** of the lift system.
5. Lower the lift system with the tip switch **Fig. 100-105**.
6. Mount the suction mouth to the lift system using bolts, washers and nuts.
7. Attach the holder and baffle plate **Fig. 100-F** to the frame of the front tool carrier **Fig. 100-G**.
8. Make the connections.
 - Slightly grease the suction hose **Fig. 100-H** and attach it to the suction duct.
 - Connect the hydraulic hose **Fig. 100-I** for the coarse material flap.
 - Attach the circulating water hose **Fig. 100-J** to the suction duct.
 - Attach the fresh water hose **Fig. 100-K** to the suction duct.

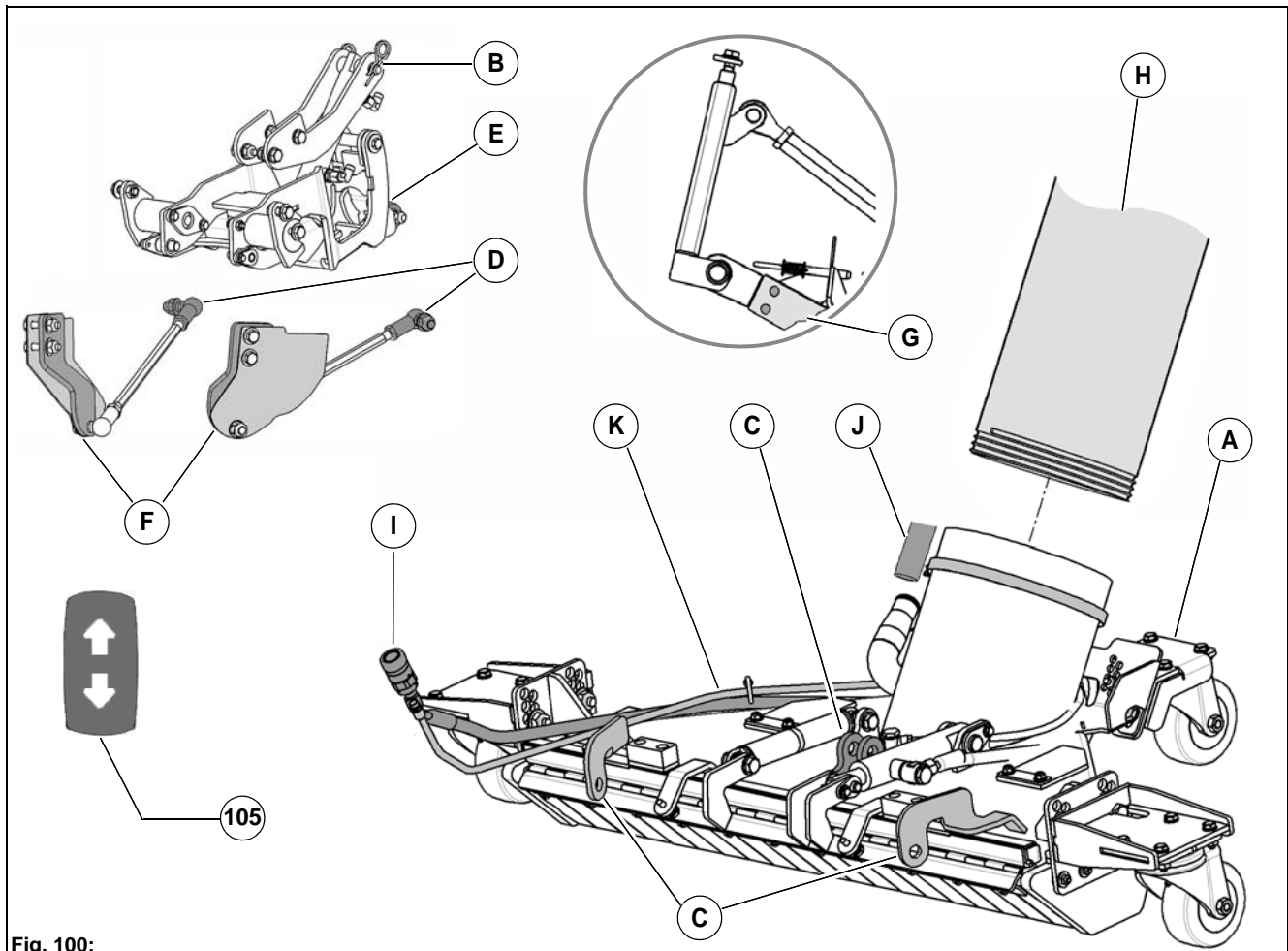

Fig. 100:

3.4.3 Mounting the sweeping unit (2-brush system)

Observe the Safety instructions – Vacuum sweeping system, see page 130.

1. Place the vehicle on a level surface and hold it with the parking brake.
 2. Use the upper link **Fig. 101-A** to adjust the lowered front tool carrier **Fig. 101-18** vertically.
 3. Lower the front tool carrier with the tip switch **Fig. 101-105**. If necessary, adjust the lowering speed with the throttle valve **Fig. 101-168**.
 4. Remove the M16 fastening bolt and the washer **Fig. 101-B** of the front tool carrier.
 5. Use the trolley **Fig. 101-C** (option) to align the sweeping unit **Fig. 101-27** centrally and in alignment with the front tool carrier.
 6. Raise the front tool carrier with the tip switch **Fig. 101-105** and attach the sweeping unit.
 7. Secure the sweeping unit using a washer and M16 fastening bolt. Remove the trolley from the sweeping unit.
- With the option 'sweeping unit with weed brush' **Fig. 101-D**, carry out installation accordingly.

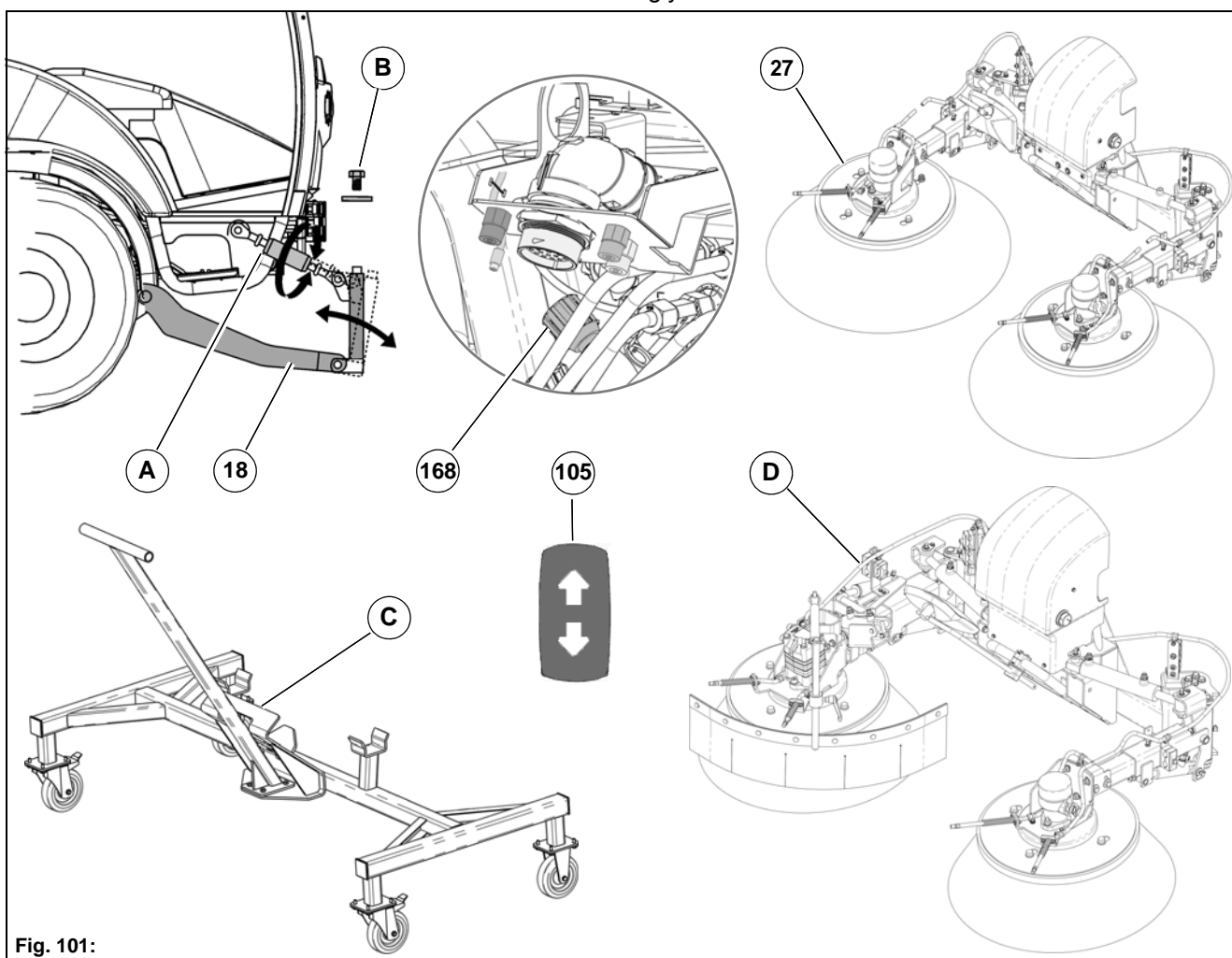

Fig. 101:

Continued – Mounting the sweeping unit (2-brush system)

8. Make the connections.

- Return control block, sweeping unit = **Fig. 102-155**
- Spray nozzle, sweeping unit = **Fig. 102-157**
- Spray nozzle, sweeping unit = **Fig. 102-158**
- 23-pin coding plug = **Fig. 102-159**
- Supply control block, sweeping unit = **Fig. 102-160**
- LS connection for control block, sweeping unit (demand-based oil supply) = **Fig. 102-161**

Dismantling is in reverse order.

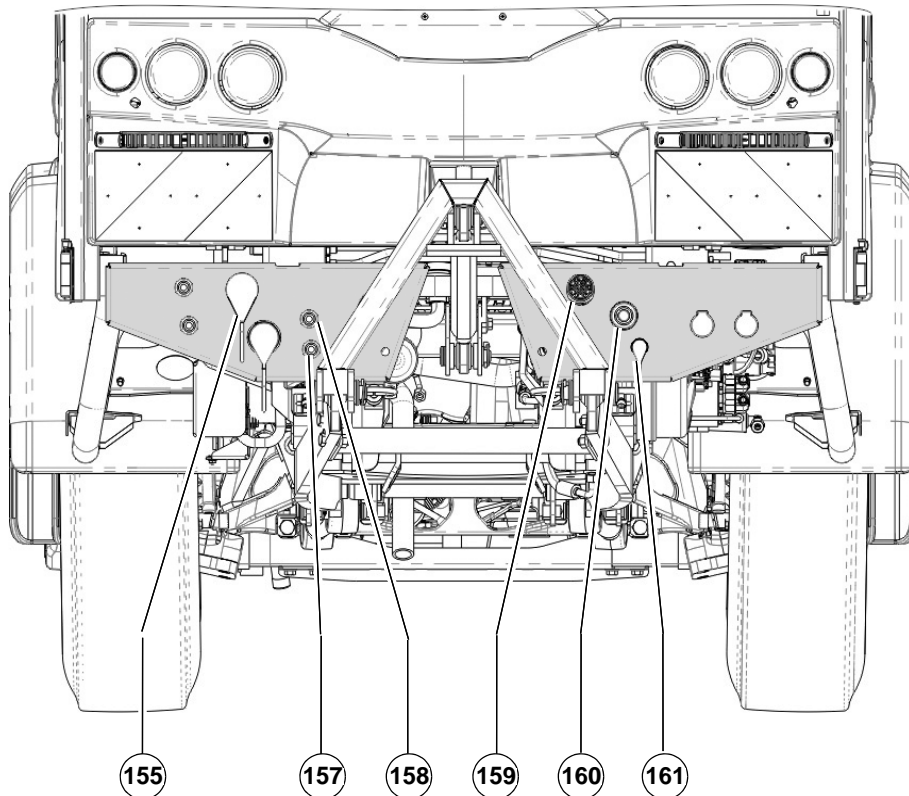

Fig. 102:

3.4.4 Mounting the sweeping unit (3-brush system)

Observe the Safety instructions – Vacuum sweeping system, see page 130.

1. Place the vehicle on a level surface and hold it with the parking brake.
2. Use the upper link **Fig. 103-A** to adjust the raised front tool carrier **Fig. 103-18** vertically.
3. Lower the front tool carrier with the tip switch **Fig. 103-105**.
4. Remove the M16 fastening bolt and the washer **Fig. 103-B** of the front tool carrier.
5. Use the trolley **Fig. 103-D** (option) to align the sweeping unit **Fig. 103-27** centrally and in alignment with the front tool carrier.
6. Raise the front tool carrier with the tip switch **Fig. 103-105** and attach the sweeping unit.
7. Hold the front tool carrier in the raised position with the throttle valve **Fig. 103-168**. If necessary, adjust the lowering speed of the suction mouth with the throttle valve **Fig. 103-C**.
8. Secure the sweeping unit using a washer and M16 fastening bolt. Remove the trolley from the sweeping unit.

With the option 'sweeping unit with weed brush' **Fig. 103-E**, carry out installation accordingly.

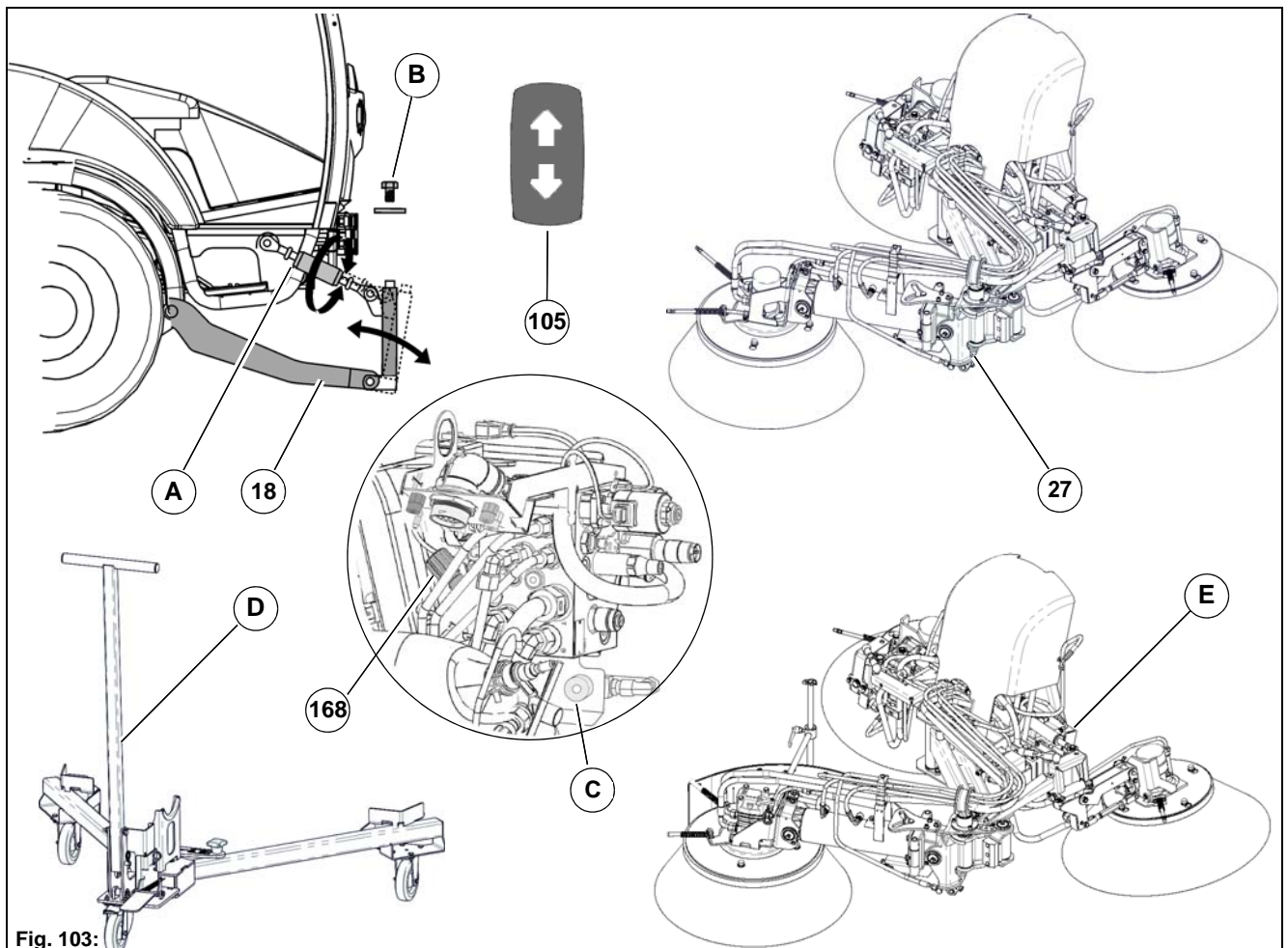

Fig. 103:

Continued – Mounting the sweeping unit (3-brush system)

9. Make the connections.

- Return control block, sweeping unit = **Fig. 104-155**
- Spray nozzle, sweeping unit = **Fig. 104-157**
- Spray nozzle, sweeping unit = **Fig. 104-158**
- 23-pin coding plug = **Fig. 104-159**
- Supply control block, sweeping unit = **Fig. 104-160**
- LS connection for control block, sweeping unit (demand based oil supply) = **Fig. 104-161**

Dismantling is in reverse order.

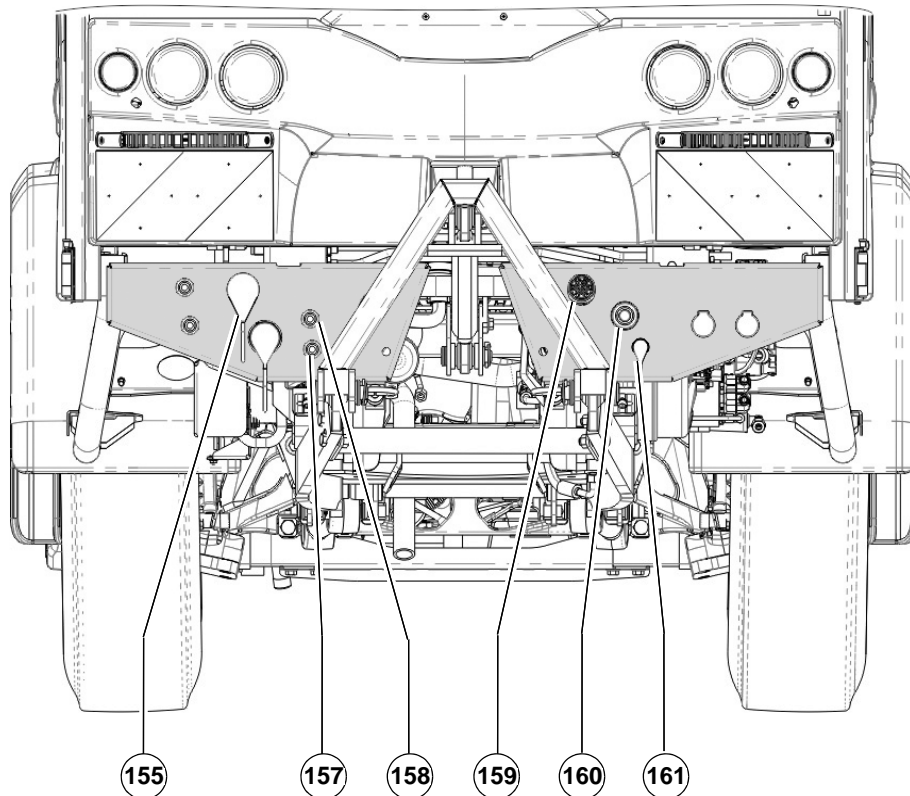

Fig. 104:

3.4.5 Mounting the dirt hopper

Observe the Safety instructions – Vacuum sweeping system, see page 130.

1. Place the vehicle on a level surface and hold it with the parking brake. The dirt hopper must be emptied.
2. Remove the buffers **Fig. 105-F** at the rear supports.
3. Use the four cranks **Fig. 105-A** of the front and rear supports **Fig. 105-B** to evenly raise the dirt hopper **Fig. 105-26** and slide over the four tipper balls **Fig. 105-C** of the vehicle.
4. Align the ball holders **Fig. 105-D** of the dirt hopper to the tipper balls of the vehicle frame.
5. Use the cranks of the supports to evenly lower the dirt hopper.
6. Secure the dirt hopper at the vehicle frame using fastening bolts **Fig. 105-E** and splints.

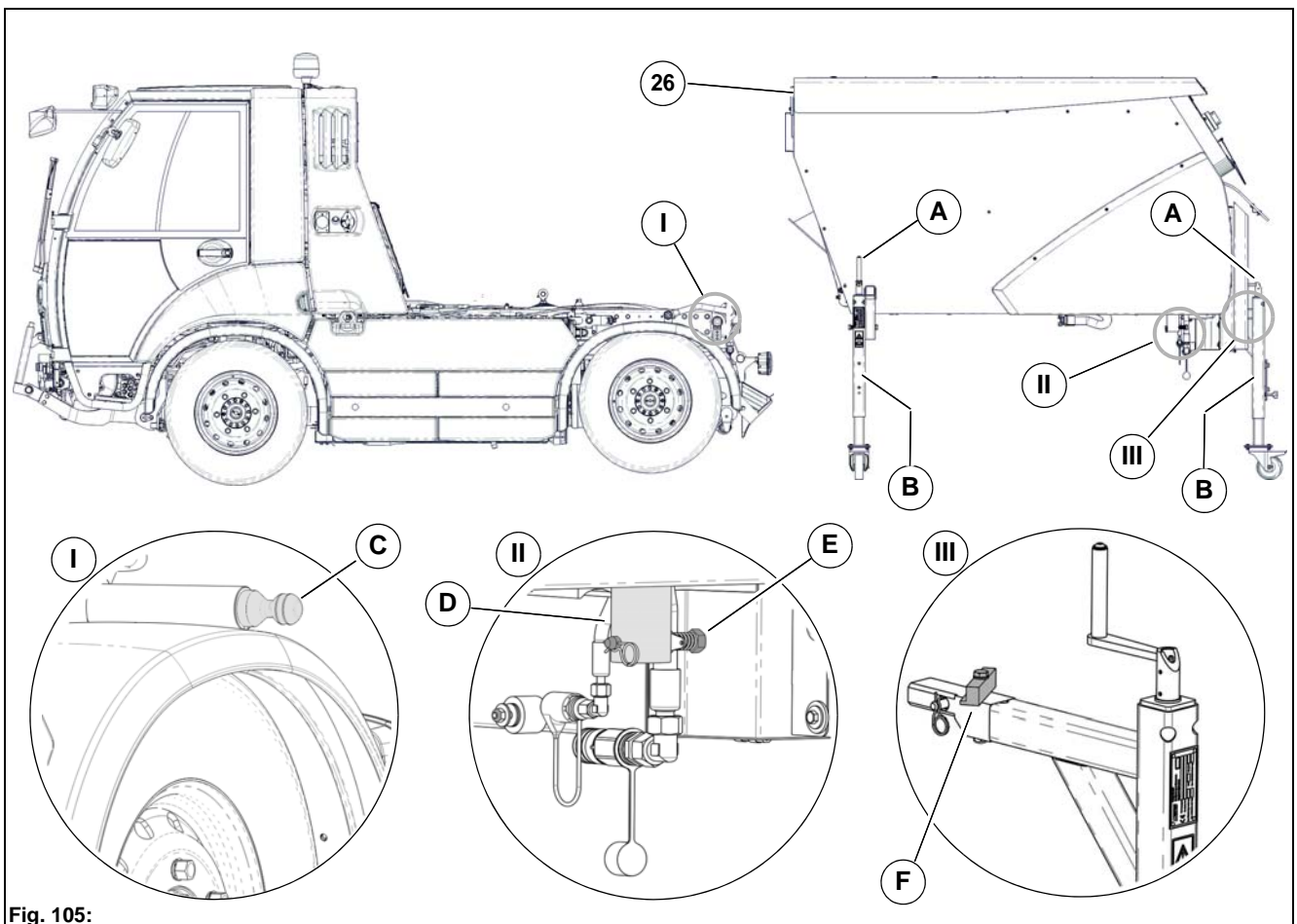

Fig. 105:

7. Raise the lifting cylinder **Fig. 106-A** with the hydraulic hand pump **Fig. 106-B** (on the right-hand side of the vehicle). Make sure the swivel head of the lifting cylinder is in alignment with the attachment **Fig. 106-C** of the dirt hopper.
8. Insert the safety pin **Fig. 106-D** into the attachment and the swivel head and secure with the locking pin.

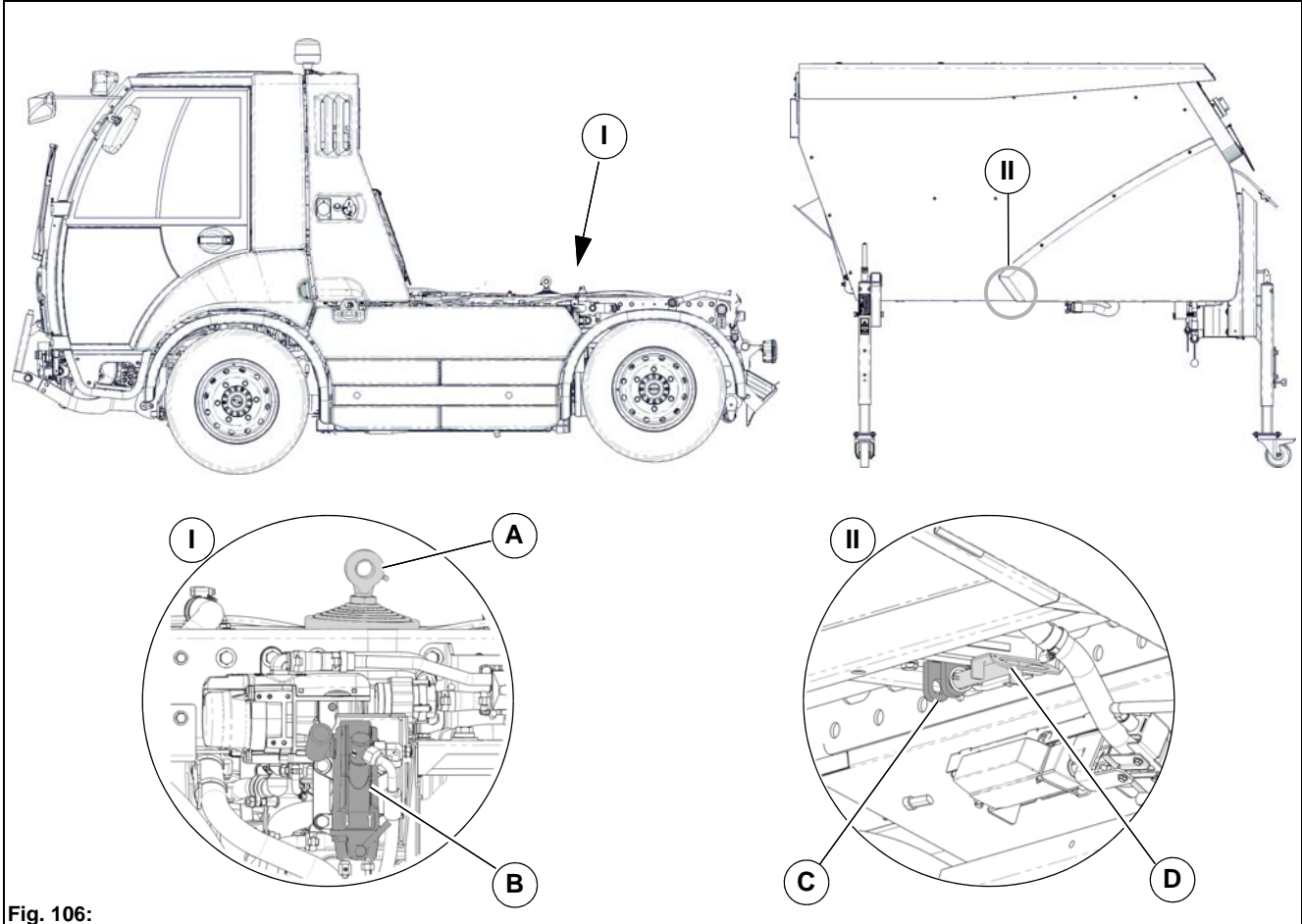

Fig. 106:

9. Make the connections.

- Pressure connection for suction fan, plug **Fig. 108-171**
- Return for suction fan, sleeve **Fig. 108-172**
- Swivel function – open dirt hopper flap, sleeve (green) **Fig. 108-173**
- Swivel function – open dirt hopper flap, sleeve (green) **Fig. 108-174**
- 23-pin coding plug **Fig. 108-166**
- Plug connection for 1st fresh water pump **Fig. 108-164**
- Plug connection for 2nd fresh water pump (option) **Fig. 108-165**
- Socket for rear video camera (option) **Fig. 108-167**
- Geka coupling for circulating water = **Fig. 108-A**
- Geka coupling for high-pressure cleaner (option), see page 151

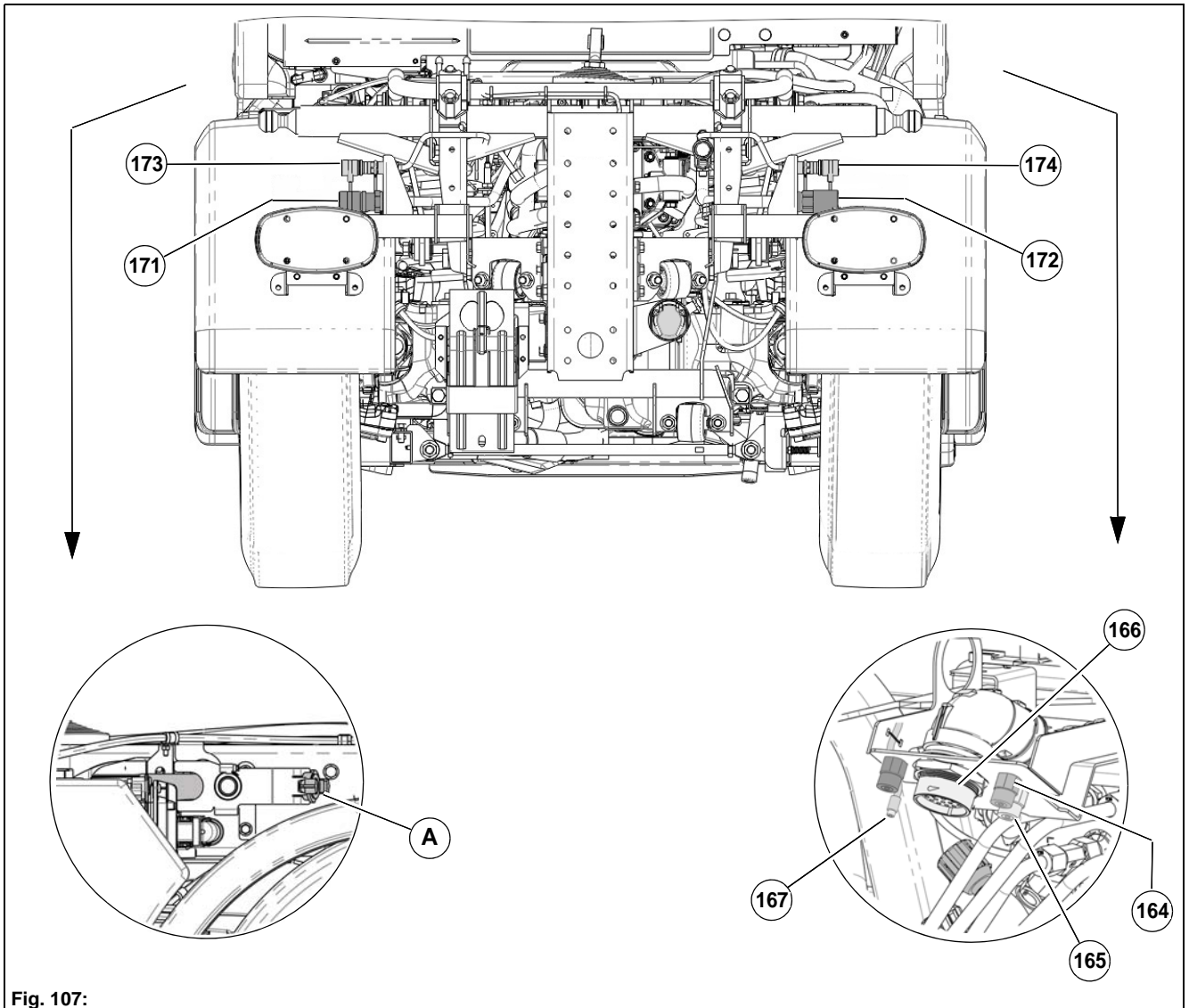

Fig. 107:

10. Raise the dirt hopper with the tip switch **Fig. 108-108**. Work in groups of two to remove the cross-beam **Fig. 108-A** of the front supports.
 11. Use the cranks to lower all the supports and remove the fastening bolts. Remove the supports from the change rack of the dirt hopper.
 12. Lower the dirt hopper with the tip switch **Fig. 108-108**.
- Dismantling is in reverse order.

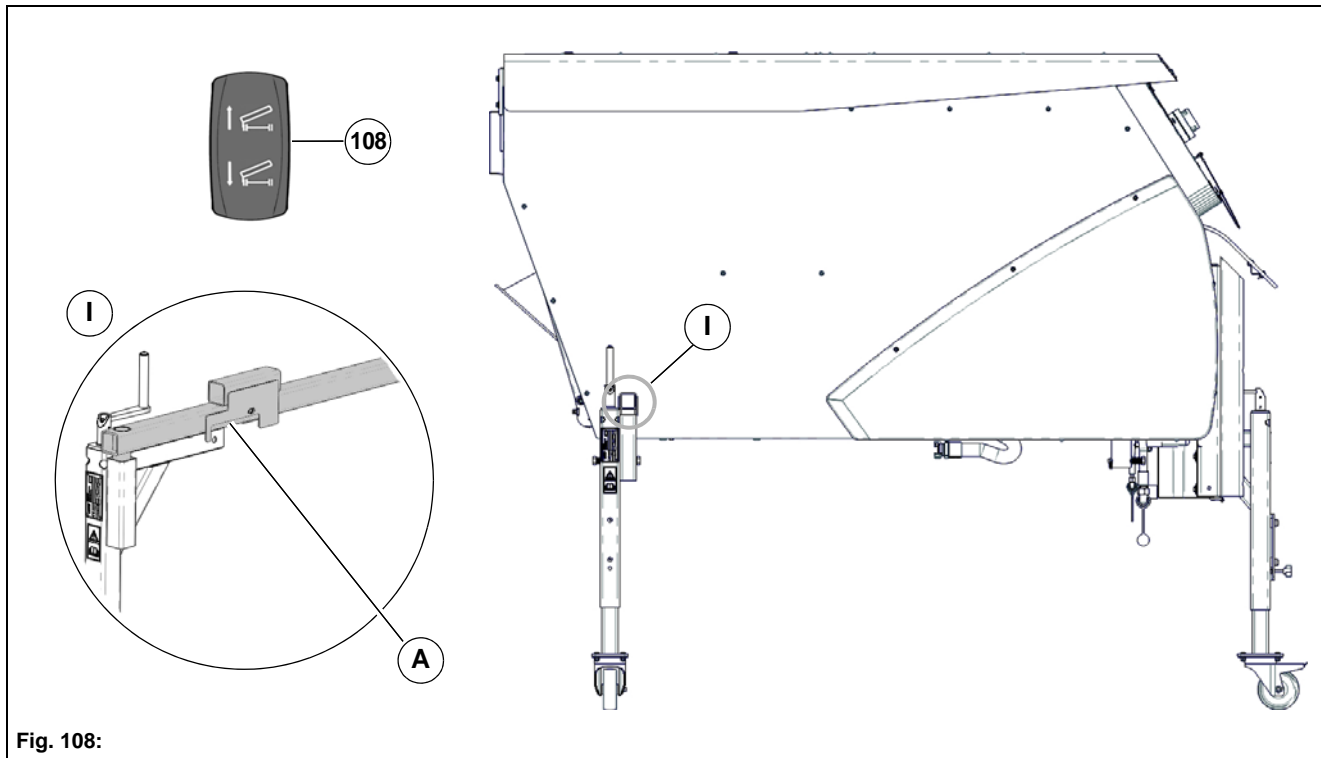

Fig. 108:

3.4.6 Before start-up of the vacuum sweeping system

No.	Description	Page
1	Check all items from the checklist – Before start-up of the vehicle	109
2	Filling fresh water	141
3	Filling circulating water	142
4	Checking the presetting of 3rd brush	223
5	Checking the sweeping level	224
6	Checking the suction mouth sealing strips	226
7	Checking the suction duct seal	228
8	Checking the dirt hopper seal	228
9	Checking the lubrication points	224

Filling the fresh water tank

Fill the fresh water tank **Fig. 109-A** before commencing work or as required. The level of the fresh water tank is monitored. If the level is too low, the symbol **Fig. 111-B** appears in the multifunction display. Raise the rubber skirt **Fig. 109-C** and open the filler cap **Fig. 109-D**. Fill the fresh water tank using a water hose. Tank volume, see Technical data.

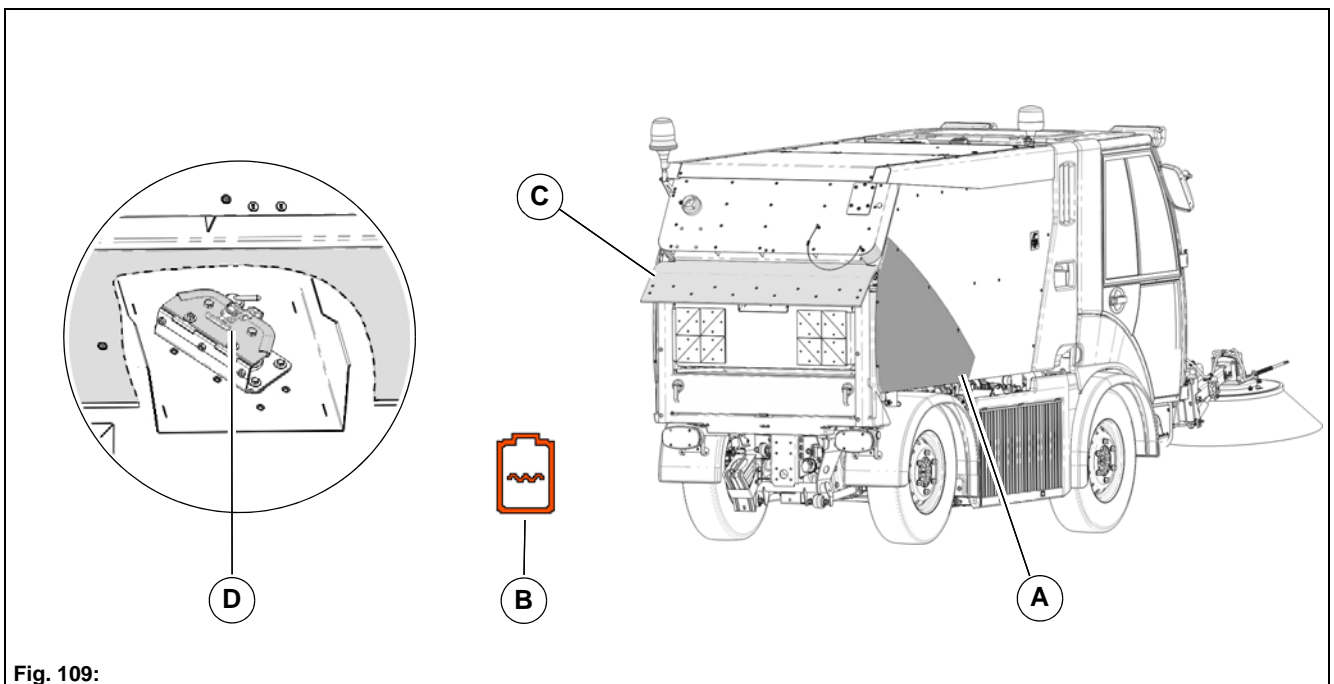
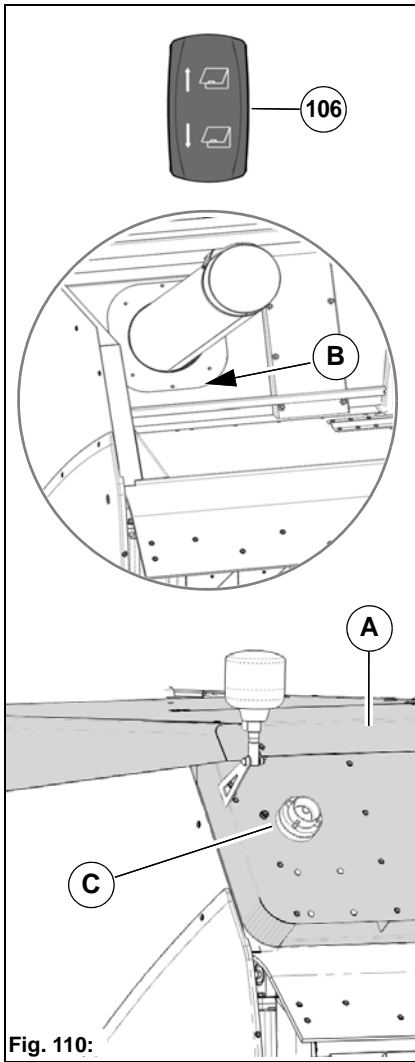

Fig. 109:

Filling circulating water



In order to enable long-term and dust-free sweeping, the circulating water system in the dirt hopper **Fig. 110-A** should be filled with water prior to each sweeping operation.

1. Drive the vehicle to a suitable water extraction point.
2. Secure the vehicle with the parking brake.
3. Open the dirt hopper flap **Fig. 110-A** with the tip switch **Fig. 110-106**.
4. Connect the water hose and fill the dirt hopper with water up to the lower edge of the suction duct flange **Fig. 110-B**. Use the C hose connection **Fig. 110-C** as an alternative.

Filling quantity, see Technical data.



Note

If too much circulating water was taken up (for example due to rain water) during the sweeping operation, the surplus quantity can be drained from the dirt hopper via a hand valve, see page 153.

Fig. 110:

3.4.7 Operating the vacuum sweeping system

No.	Description	Page
1	Driving to the work site	143
2	Starting vacuum sweeping	144
3	Adjusting the sweeping unit	145
4	Setting the suction fan speed	146
5	Setting the brush speed	146
6	Setting the brush pressure	147
7	Opening the coarse material flap	147
8	Setting the fresh water supply	148

Driving to the work site

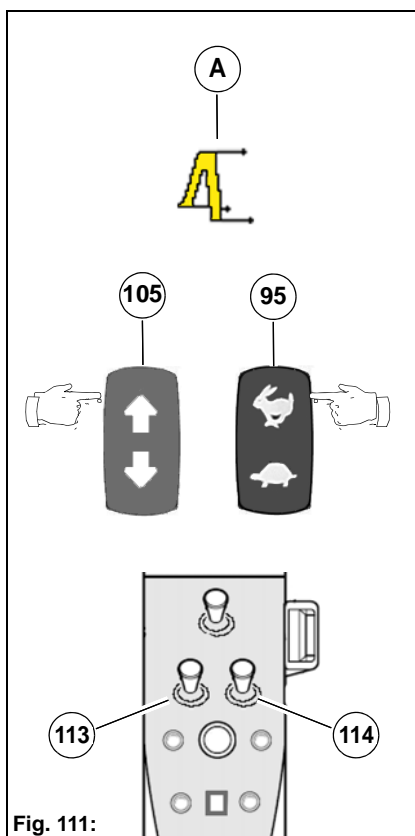

Fig. 111:

1. Start the vehicle, see page 111
2. Use the joysticks **Fig. 111-113 and 114** to swivel the brush in.
3. Raise the front tool carrier with the tip switch **Fig. 111-105**.
4. If necessary, attach the transport protection device of the front tool carrier, see page 124.
5. Switch on transport mode with the tip switch **Fig. 111-95** and move off, see page 113. In transport mode, the forward speed is 0 to 62 km/h and the reverse speed is 0 to 25 km/h.



Note

If the front tool carrier is lowered in transport mode or offset mode, the yellow symbol **Fig. 111-A** appears in the multifunction display.

Starting vacuum sweeping

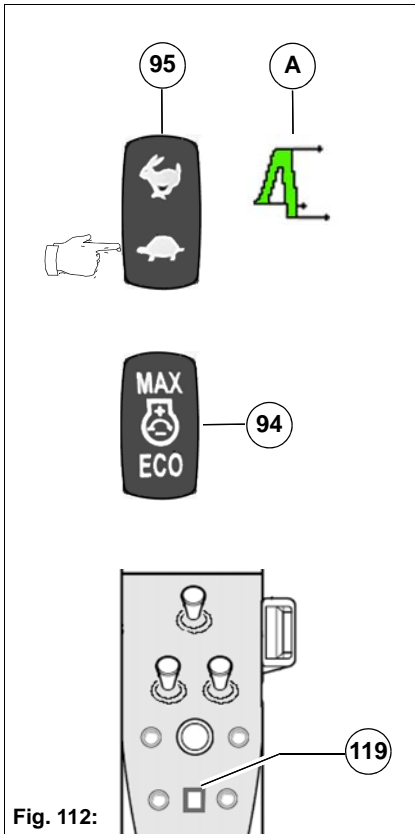
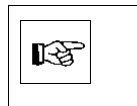

Fig. 112:

Observe the Safety instructions – Vacuum sweeping system, see page 130.

1. Start the vehicle, see page 111
2. Switch on the work mode with the tip switch **Fig. 112-95**.
 - The sweeping unit is lowered.
 - The green symbol **Fig. 112-A** appears in the multifunction display.
3. Carry out the settings for vacuum sweeping:
 - Adjusting the sweeping unit, see page 145
 - Setting the suction fan speed, see page 146
 - Setting the brush speed, see page 146
 - Setting the brush pressure, see page 147
 - Setting the fresh water supply, see page 148



Note

If work mode is switched back on after an interruption, all vacuum sweeping settings are reactivated.

4. Move off, see page 113.
 - In work mode, the forward speed is 0 to 15 km/h and the reverse speed is 0 to 15 km/h.
5. The desired engine speed for work mode is adjusted with the tip switch **Fig. 112-94**. Set the speed according to the requirements.

Stage	rpm	Use
1 - ECO	1400	Slight soiling or operation on flat ground <ul style="list-style-type: none"> • The brush and suction fan speeds are limited. When switching off ECO mode, the engine speed increases to 1700 rpm again.
2 - Standard	1700	Any soiling or operation on medium slopes
3 - Maximum	2000	Any soiling or operation on steep slopes

6. If necessary in work mode, switch on the reversing tip switch **Fig. 112-119** when driving forwards. This enables brief reverse sweeping.

Work mode with cruise control

In work mode, it is possible to drive via cruise control (only when driving forwards).

Switch on the cruise control: Press the tip switch **Fig. 113-99**.

Switch off the cruise control: Press the tip switch **Fig. 113-99** or

- Actuate the service brake
- Change the drive switch to neutral or reverse
- Actuate the reversing tip switch

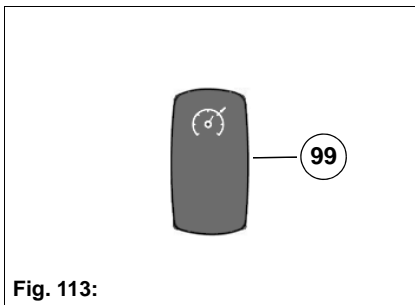

Fig. 113:

Adjusting the sweeping unit

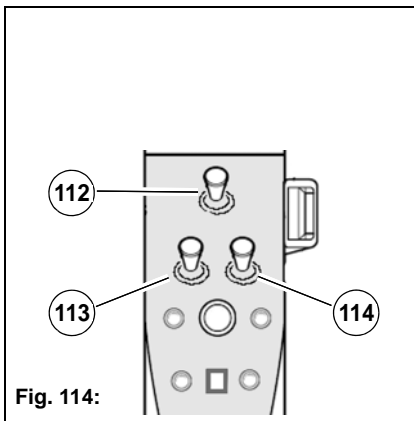

Fig. 114:

Sweeping unit with 2-brush system

With a sweeping unit with 2-brush system (option), the following functions are set using the joysticks **Fig. 114-112, 113 and 114**

Joystick **Fig. 114-113:**

- Joystick forwards: The left-hand brush is lowered (floating position)
- Joystick backwards: The left-hand brush is raised
- Joystick to the left: The left-hand brush swings to the left
- Joystick to the right: The left-hand actuator swings to the right

Joystick **Fig. 114-114:**

- Joystick forwards: The right-hand brush is lowered (floating position)
- Joystick backwards: The right-hand brush is raised
- Joystick to the left: The right-hand brush swings to the left
- Joystick to the right: The right-hand actuator swings to the right



Note

With a 2-brush system, the joystick **Fig. 114-112** is only used in conjunction with a weed brush (option). Set the angle of the weed brush with the joystick.

Sweeping unit with 3-brush system

With a sweeping unit with 3-brush system (option), the following functions are set using the joysticks **Fig. 115-112, 113 and 114**

Joystick **Fig. 115-112:**

- Joystick forwards: The 3rd brush is tilted forwards
- Joystick backwards: The 3rd brush is tilted backwards
- Joystick to the left: The 3rd brush is tilted to the left
- Joystick to the right: The 3rd brush is tilted to the right

Joystick **Fig. 115-113:**

- Joystick forwards: The 3rd brush is lowered
- Joystick backwards: The 3rd brush is raised
- Joystick to the left: The 3rd brush swivels to the left
- Joystick to the right: The 3rd brush swivels to the right

Joystick **Fig. 115-114:**

- Joystick forwards: The pulled brushes are lowered (floating position)
- Joystick backwards: The pulled brushes are raised
- Move the joystick to the left: The pulled brushes swing in
- Move the joystick to the right: The pulled brushes swing out

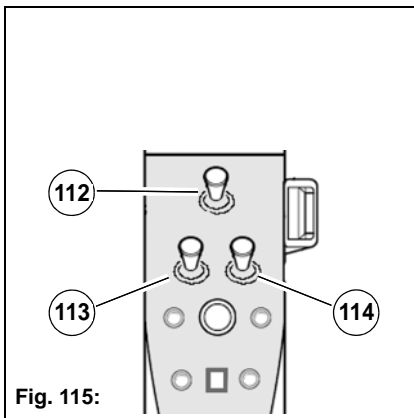

Fig. 115:

Swivelling the 3rd brush / Reversing the direction of rotation

In order to change the 3rd brush to a different side with a 3-brush system, actuate the switch **Fig. 115-103**.

The 3rd brush is swivelled and the direction of rotation reversed.

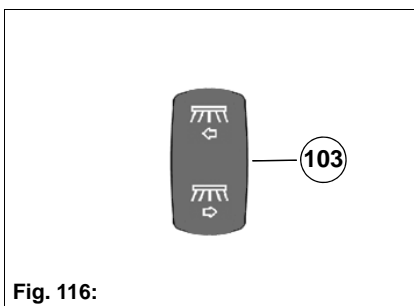

Fig. 116:

Setting the suction fan speed

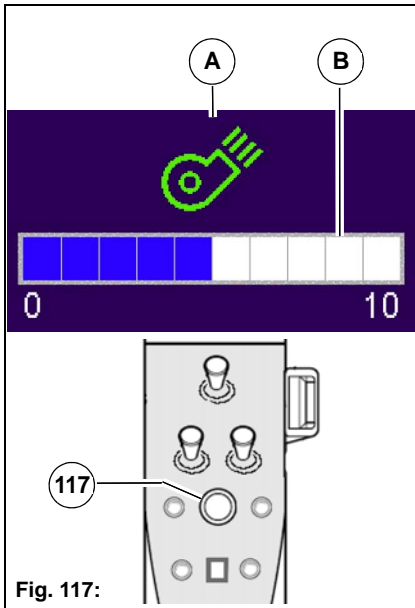

Fig. 117:

The suction fan speed can be set in the adjustment menu of the multifunction display.

- Briefly press the turn-push knob **Fig. 117-117** to select the adjustment menu **Fig. 117-A** for the fan suction speed.
- Rotating the turn-push knob **Fig. 117-117** changes the value in the bar chart **Fig. 117-B**. The bar chart is divided into 10 increments.



Note

Dry leaves can be swept best of all at medium suction fan speed. The suction power is sufficient and the coarse sieve on the suction fan of the dirt hopper does not clog so quickly.

Setting the brush speed

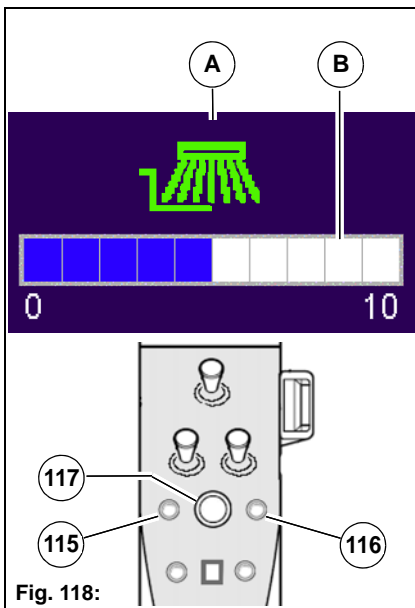

Fig. 118:

The brush speed can be set in the adjustment menu of the multifunction display.

- Briefly pressing the quick select buttons **Fig. 118-115** or **Fig. 118-116** switches the main consumer on/off and opens the adjustment menu of the respective main consumer.
- Rotating the turn-push knob **Fig. 118-117** changes the value in the bar chart **Fig. 118-B**. The bar chart is divided into 10 increments.
- Briefly pressing the turn-push knob **Fig. 118-117** displays the next function.

The last set function is displayed after a new selection.

Setting the brush pressure

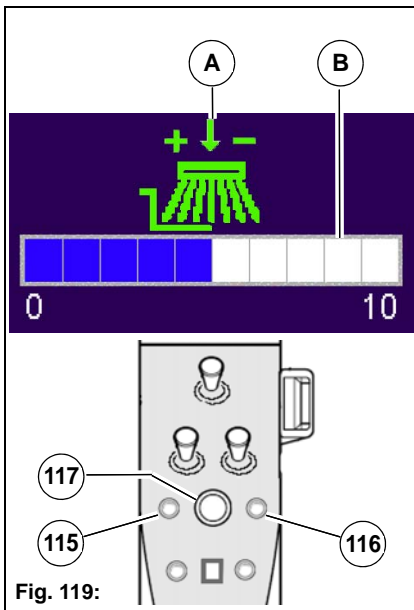

Fig. 119:

The brush pressure can be set in the adjustment menu of the multifunction display.

- Briefly pressing the quick select buttons **Fig. 119-115** or **Fig. 119-116** switches the main consumer on/off and opens the adjustment menu of the respective main consumer.
- Briefly pressing the turn-push knob **Fig. 119-117** changes to the next function.
- Rotating the turn-push knob **Fig. 119-117** changes the value in the bar chart **Fig. 119-B**. The bar chart is divided into 10 increments.

The last set function is displayed after a new selection.

Opening the coarse material flap

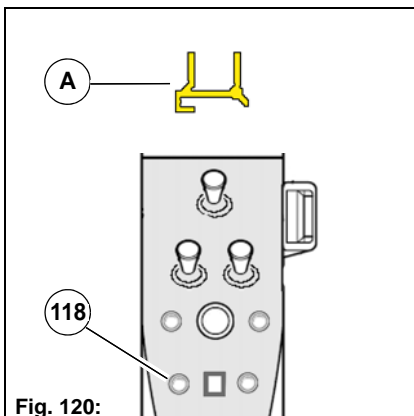

Fig. 120:

If there are larger objects or coarse dirt (cans, bottles, leaves, etc.) in front of the suction mouth, you can open the coarse material flap on the suction mouth by pressing the tip switch **Fig. 120-118**.

- Actuate the tip switch **Fig. 120-118** briefly: The coarse material flap opens and closes again automatically.
- Actuate the tip switch **Fig. 120-118** for longer: The coarse material flap opens and only closes again after actuating the tip switch again.

If the coarse material flap is open, the symbol **Fig. 120-A** appears in the multifunction display.

Setting the fresh water supply

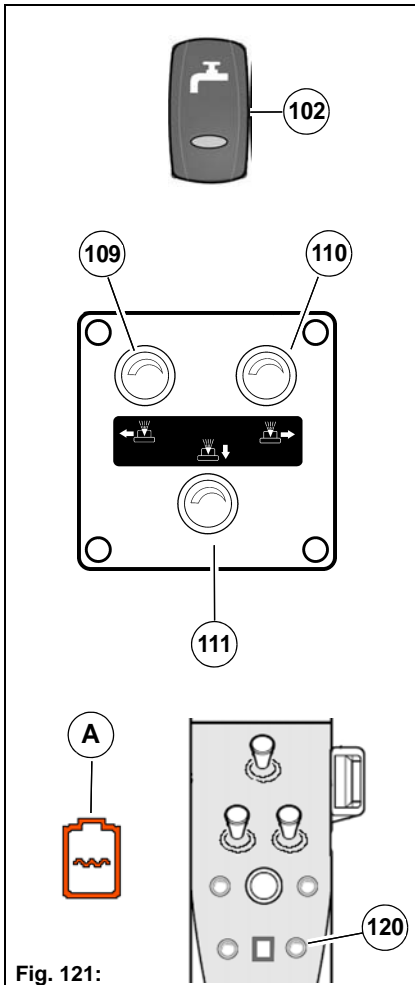

Fig. 121:

If dust formation is too great on dry ground, the fresh water supply can be switched on to bind the dust. Use the switch **Fig. 121-120** to switch the fresh water pump on and off.

Fresh water is additionally supplied to the upper part of the suction duct via a second fresh water pump (option). Use the tip switch **Fig. 121-102** to switch the second fresh water pump on and off.

The flow rate at the spray nozzles is controlled via the valves **Fig. 121-109, 110 and 111**. Set the fresh water volume according to the requirements.

- Low dust formation – reduce fresh water volume with the valve.
- Severe dust formation – increase fresh water volume with the valve.

Assignment of the valves with a sweeping unit with 2-brush system:

- Valve – fresh water nozzle **Fig. 121-109**: left brush
- Valve – fresh water nozzle **Fig. 121-110**: right brush
- Valve – fresh water nozzle **Fig. 121-111**: suction duct

Assignment of the valves with a sweeping unit with 3-brush system:

- Valve – fresh water nozzle **Fig. 121-109**: 3rd brush
- Valve – fresh water nozzle **Fig. 121-110**: pulled brushes
- Valve – fresh water nozzle **Fig. 121-111**: suction duct

The level of the fresh water tank is monitored. If the level is too low, the symbol **Fig. 121-A** appears in the multifunction display.

3.4.8 Operating the vacuum sweeping system with the multifunction handle (option)

Fig. 122:

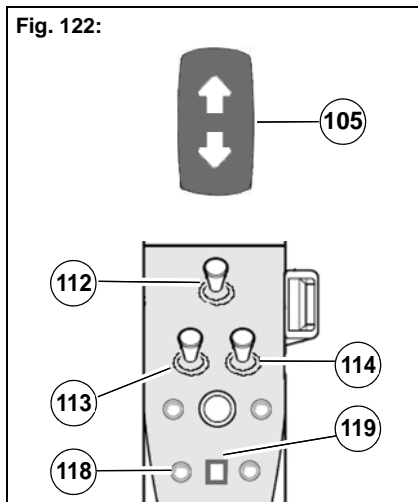

To ensure convenient operation of the sweeping unit with 3-brush system, the vehicle can be equipped with a multifunction handle Fig. 123-153.



Note

The following elements in the centre console are not available with this version: Joystick Fig. 122-112, Joystick Fig. 122-113, Joystick Fig. 122-114, tip switch Fig. 122-118, tip switch Fig. 122-119 and switch Fig. 122-105.

The switches and tip switches of the multifunction handle are assigned the following functions:

Switch	Function
A	Actuating the coarse material flap <ul style="list-style-type: none"> • Switching off the switch: coarse material flap closed • Switching on the switch: coarse material flap open
B	Brush preselection: <ol style="list-style-type: none"> 1 Pulled brushes (raise, lower and swivel) 2 Raise, lower and swivel 3rd brush 3 Incline and tilt 3rd brush
C	Type of function depending on the brush preselection: <ul style="list-style-type: none"> • Raise, lower and swivel • Incline and tilt

Tip switch	Function
D	Raising the front tool carrier
E	Lowering the front tool carrier
F	Lifting the left brush individually
G	Lifting the right brush individually
H	Reversing tip switch

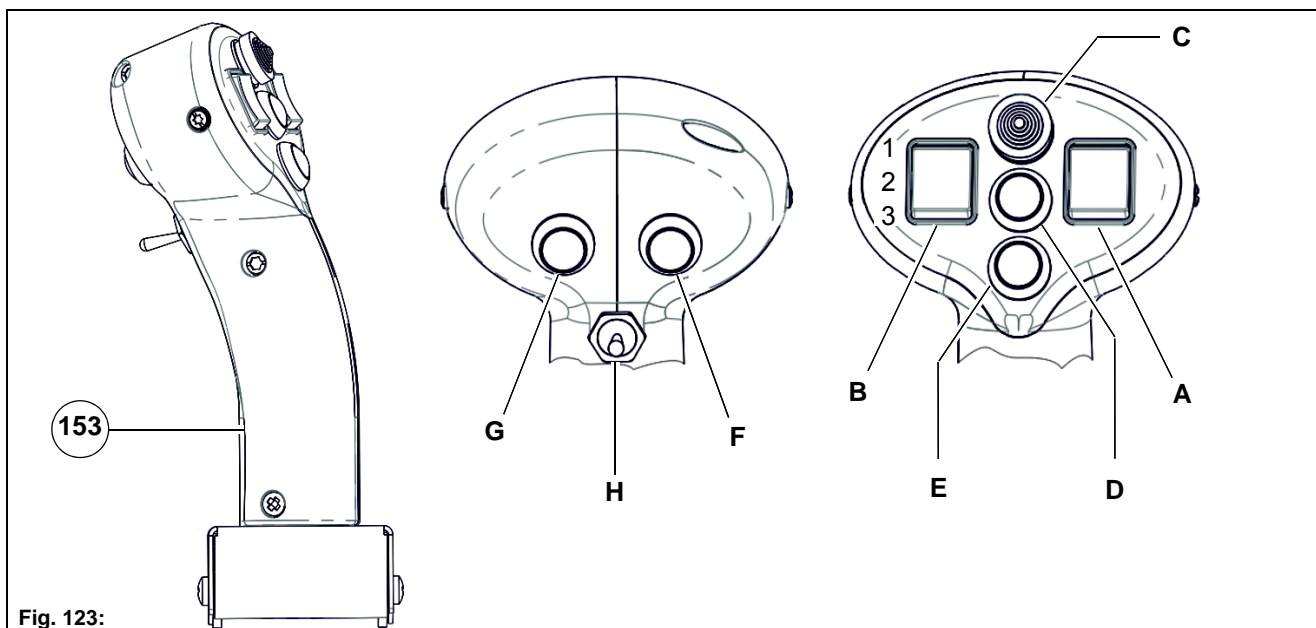

Fig. 123:

3.4.9 Hand suction hose (option)

The hand suction hose **Fig. 124-A** is used for effectively cleaning difficult-to-reach points.

1. Start the vehicle, drive to the work site and hold it with the parking brake.
2. Work with the insert plate **Fig. 124-B** in case of heavy soiling. To do so, raise the dirt hopper with the tip switch **Fig. 124-108** and insert the safety strut **Fig. 124-C**, see page 222.
3. Push the insert plate onto the rubber seal of the suction duct **Fig. 124-D**.
4. Move the dirt hopper back into its end position. To do so, unlock the safety strut with the lever **Fig. 124-E**, see page 222.
5. Switch on sweeping and raise the suction mouth with the tip switch **Fig. 124-108**.
6. Loosen the tension belt **Fig. 124-F** and the locks **Fig. 124-H** and use the handle **Fig. 124-G** to remove the hand suction hose from the side of the holder **Fig. 124-I**. Pay attention to the weight!
7. If dust formation is too great on dry ground, the fresh water supply can be switched on to bind the dust. To do so, close the valves **Fig. 124-109, 110** and **111**, switch on the fresh water pump with the switch **Fig. 124-120** and open the hand valve **Fig. 124-J** at the hand suction hose.

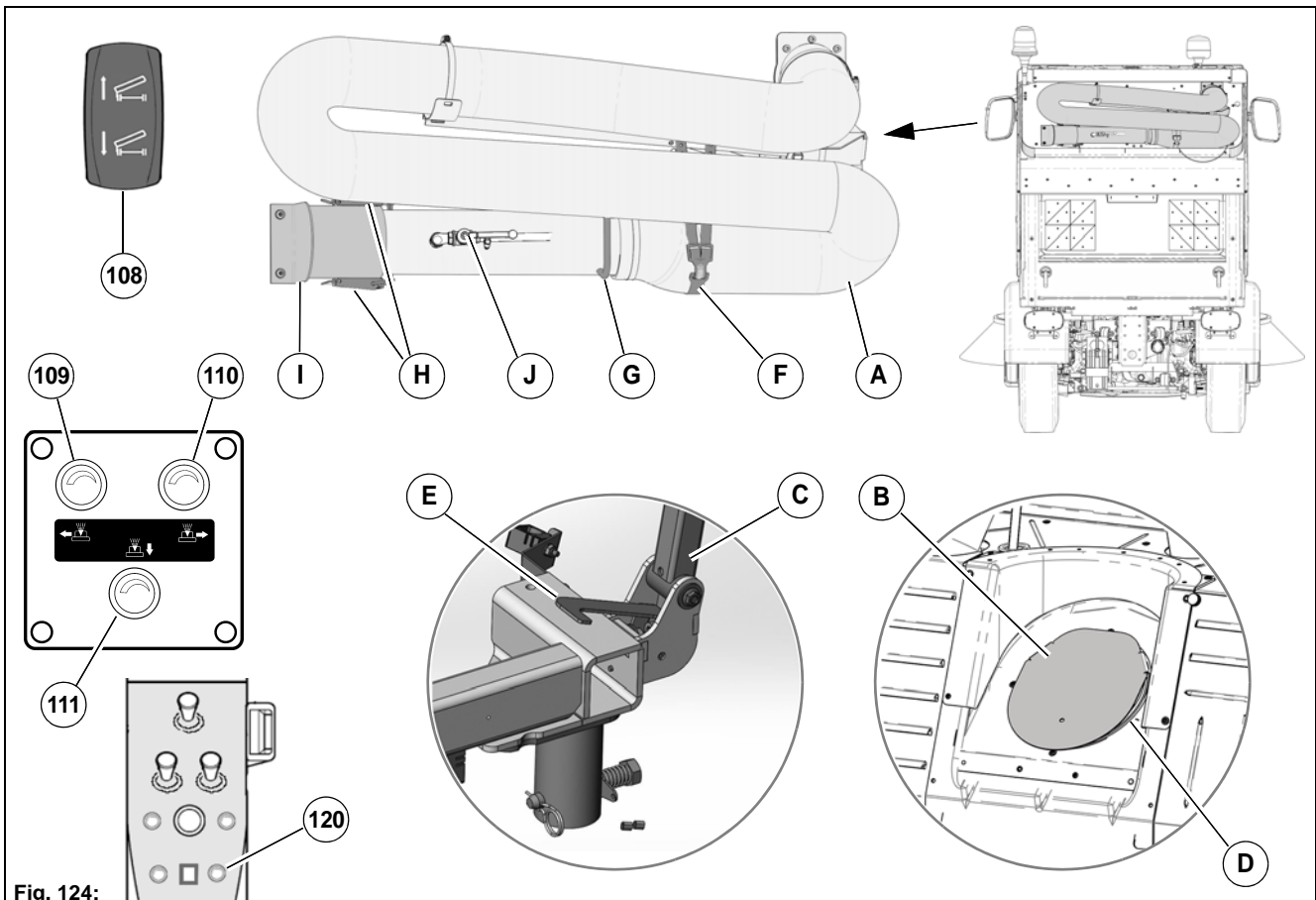

Fig. 124:

3.4.10 High-pressure cleaner (option)

Observe the Safety instructions – Vacuum sweeping system, see page 130.

Check the following before starting up the high-pressure cleaner:

- Top up fresh water tank, see page 141
 - Check the fresh water filter, see page 154
1. Start the vehicle, drive to the work site and hold it with the parking brake.
 2. Take the spray lance and the pressure hose **Fig. 125-A** out of the toolbox **Fig. 125-B** and connect them to the quick coupler **Fig. 125-C**.
 3. Start the vehicle, see page 111. Set the changeover valve **Fig. 125-D** to the high-pressure cleaner position **Fig. 125-E**.
 4. Aim the spray lance at the surface to be cleaned and switch on the water jet by pressing the lever **Fig. 125-G**. Set the desired working pressure with the pressure controller **Fig. 125-F**.



Danger

The jet of the high-pressure cleaner must not be directed to persons. There is a risk of injury! Do not use steam cleaners and high-pressure cleaners for cleaning electrical/electronic components and the engine compartment!

5. After cleaning, set the changeover valve back to the suction fan position.

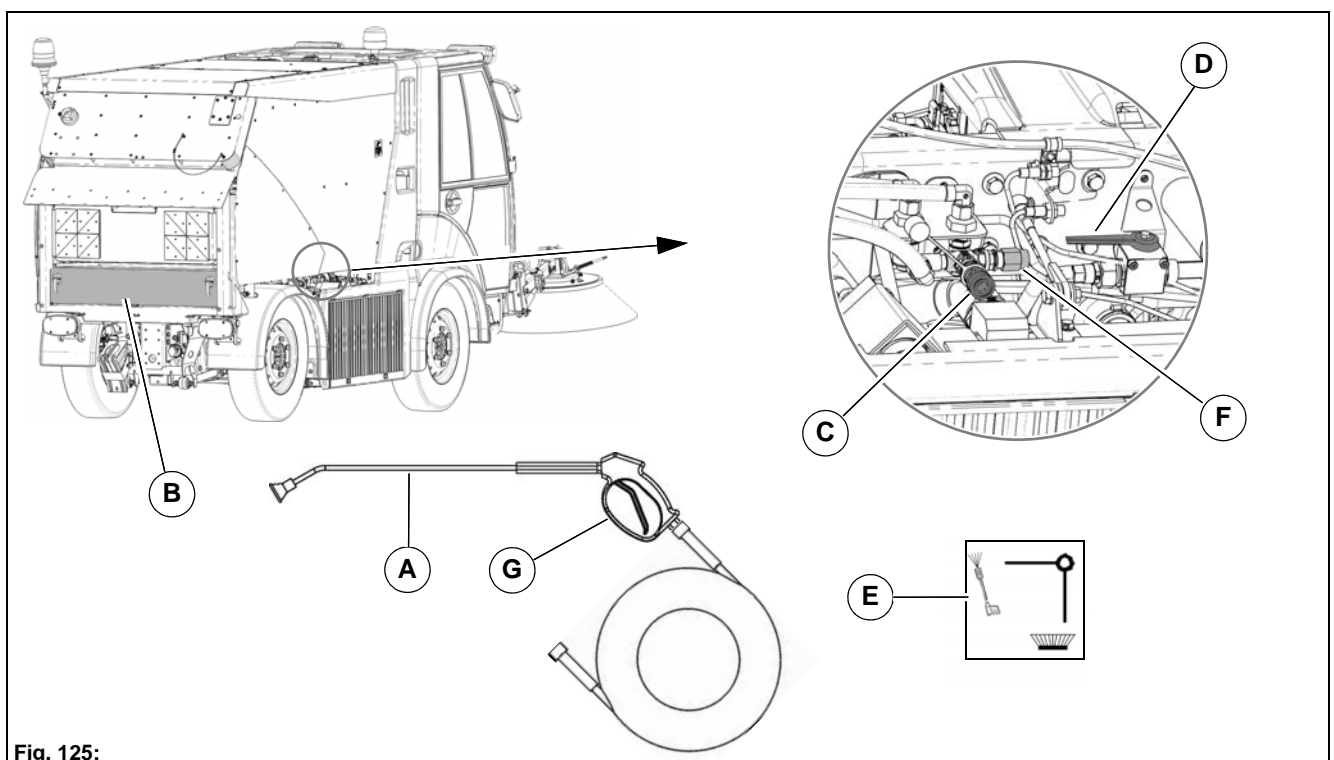

Fig. 125:

3.4.11 Cleaning the vacuum sweeping system

Observe the Safety instructions – Vacuum sweeping system, see page 130.

No.	Description	Page
1	Emptying the dirt hopper	152
2	Emptying the fresh water tank	153
3	Emptying the circulating water system	153
4	Cleaning the sweeping unit and the suction mouth	154
5	Cleaning the suction fan	155
6	Cleaning the dirt hopper	156
7	Cleaning the circulating water system	157

Emptying the dirt hopper

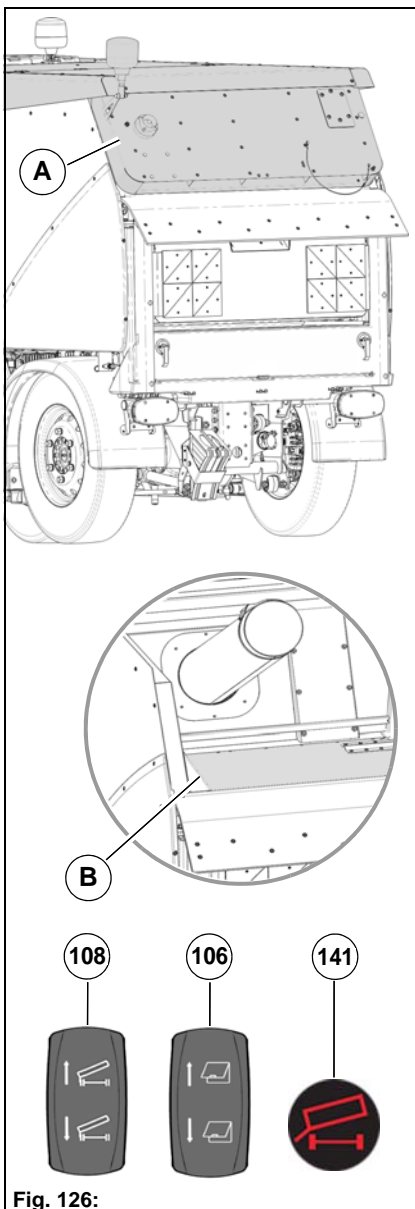

Fig. 126:

Empty the dirt hopper if the suction power deteriorates, if the dirt is not swept away or before cleaning the vacuum sweeping system.



Attention

While emptying the dirt hopper, make sure that the sump valve **Fig. 126-B** is locked! If the sump valve is open when emptying the dirt hopper, the circulating water system may be clogged.

1. Drive the vehicle to a suitable cleaning place.
2. Reverse carefully to the offloading place and engage the parking brake.
3. Open the dirt hopper flap **Fig. 126-A** with the tip switch **Fig. 126-106**.
4. Raise and empty the dirt hopper with the tip switch **Fig. 126-108**.
5. If necessary, rinse out the dirt hopper with a water hose.
6. Lower the dirt hopper and close the dirt hopper flap again.

As long as the dirt hopper is not in its lower end position, the warning symbol **Fig. 126-141** appears in the indicating device.

External operation of the dirt hopper (option)

External operation can be activated via switches in the roof console. The tip switches are then without function.

External operation:

The dirt hopper can be raised/lowered and the hopper flap opened/closed. Simultaneously activating the functions 'raise/lower dirt hopper' has no effect. Simultaneously activating the functions 'open/close hopper flap' has no effect.

The function is only executed when the safety tip switch is pressed with your other hand at the same time as the respective tip switch.

Emptying the fresh water tank

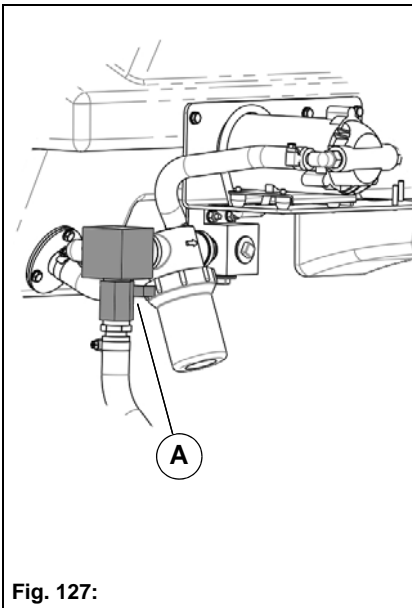

Fig. 127:

1. Drive the vehicle to a suitable cleaning place and park it safely.
2. Open the hand valve **Fig. 127-A** and empty the fresh water tank.
3. Close the hand valve again.



Note

At temperatures below 0 degrees (risk of frost), drain the water out from all water-conducting components.

Emptying the circulating water system

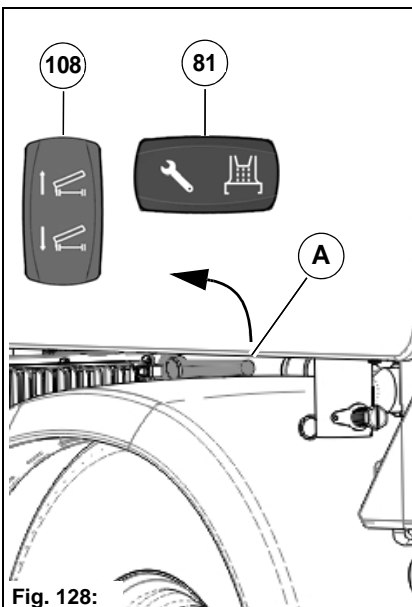

Fig. 128:

1. Drive the vehicle to a suitable cleaning place and park it safely. The drain hose of the circulating water tank is located near the left-hand rear wheel.
2. Open the circulating water valve with the switch **Fig. 128-81** when the ignition is switched on.
3. Open the hand valve **Fig. 128-A** and drain the circulating water from the dirt hopper.
4. Close the hand valve **Fig. 128-A** and close the valve with the switch **Fig. 128-81** again.



Note

At temperatures below 0 degrees (risk of frost), drain the water out from all water-conducting components.

Cleaning the sweeping unit and the suction mouth

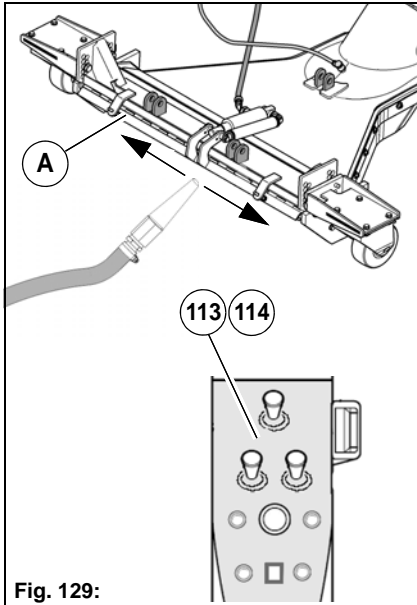

Fig. 129:

Check the sweeping unit daily for contamination and clean as required. Check the suction mouth **Fig. 129-A** daily for contamination and clean as required.

1. Drive the vehicle to a suitable cleaning place and park it safely.
2. Thoroughly clean the sweeping unit with a water hose.
3. Use the joysticks **Fig. 129-113** and **114** to raise and swing out the brush.
4. Move a water hose to and fro under the coarse material flap when the suction fan is running. Remove the contamination in the entire suction mouth with the water jet.



Note

The suction fan is only running when the dirt hopper is lowered and the dirt hopper flap is closed.

5. Empty the dirt hopper, see page 152.

Cleaning the fresh water filter

The fresh water filter **Fig. 130-A** is located on the right-hand side of the vehicle under the dirt hopper. Check the fresh water filter daily for contamination and clean as required.

1. Drive the vehicle to a suitable cleaning place and park it safely.
2. Unscrew the filter housing, check the fresh water filter for openness and clean if necessary.

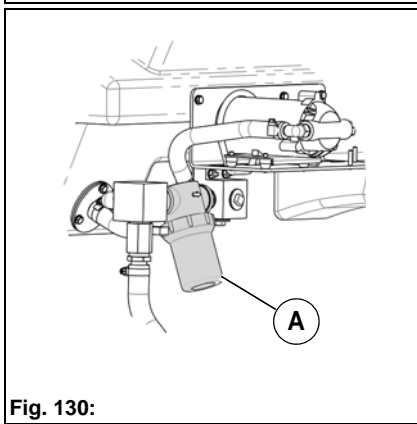

Fig. 130:

Cleaning spray nozzles and ball valve filters

The spray nozzles **Fig. 131-A** and the ball valve filters **Fig. 131-B** for the brush are located at the sweeping unit. Check the spray nozzles and the ball valve filters daily for contamination and clean as required.

1. Drive the vehicle to a suitable cleaning place and park it safely.
2. Remove the spray nozzles and the ball valve filters, check them for openness and clean if necessary.

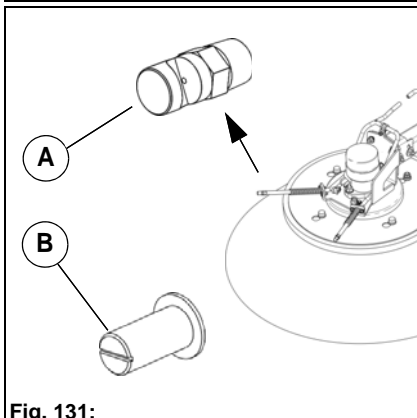
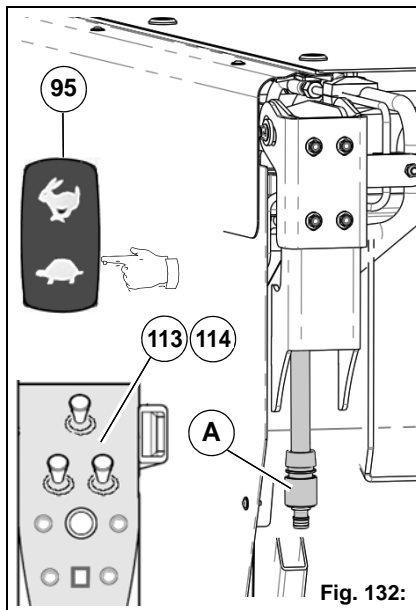

Fig. 131:

Cleaning the suction fan



Check the suction fan filter daily for contamination and clean as required.



Danger

No persons should be present behind the dirt hopper while cleaning the suction fan. There is a risk of injury!

1. Drive the vehicle to a suitable cleaning place and park it safely.
2. Connect a water hose to the water connection **Fig. 132-A** of the dirt hopper.
3. Use the tip switch **Fig. 132-95** to switch on work mode and raise the brushes with the joysticks **Fig. 132-113** and **114**.
4. Remove the contamination in the suction fan using approx. 3 bar water pressure when the suction fan is running.



Note

The suction fan is only running when the dirt hopper is lowered and the dirt hopper flap is closed.

5. Empty the dirt hopper, see page 152.

Cleaning the dirt hopper

Check the dirt hopper **Fig. 133-26** daily for contamination and clean as required. Before cleaning the dirt hopper:

- Empty the dirt hopper, see page 152.
 - Clean the sweeping unit and the suction mouth, see page 154.
 - Clean the suction fan, see page 155.
1. Drive the vehicle to a suitable cleaning place and park it safely.
 2. Open the dirt hopper flap **Fig. 133-A** with the tip switch **Fig. 133-106**.
 3. Clean the inside of the dirt hopper using a water hose. Pay particular attention to the following parts:
 - The inside of the dirt hopper flap **Fig. 133-A**
 - The grille **Fig. 133-B** of the suction fan
 - The lateral sieves **Fig. 133-C**
 - The front sieves **Fig. 133-D**
 4. Raise and empty the dirt hopper with the tip switch **Fig. 135-108**.

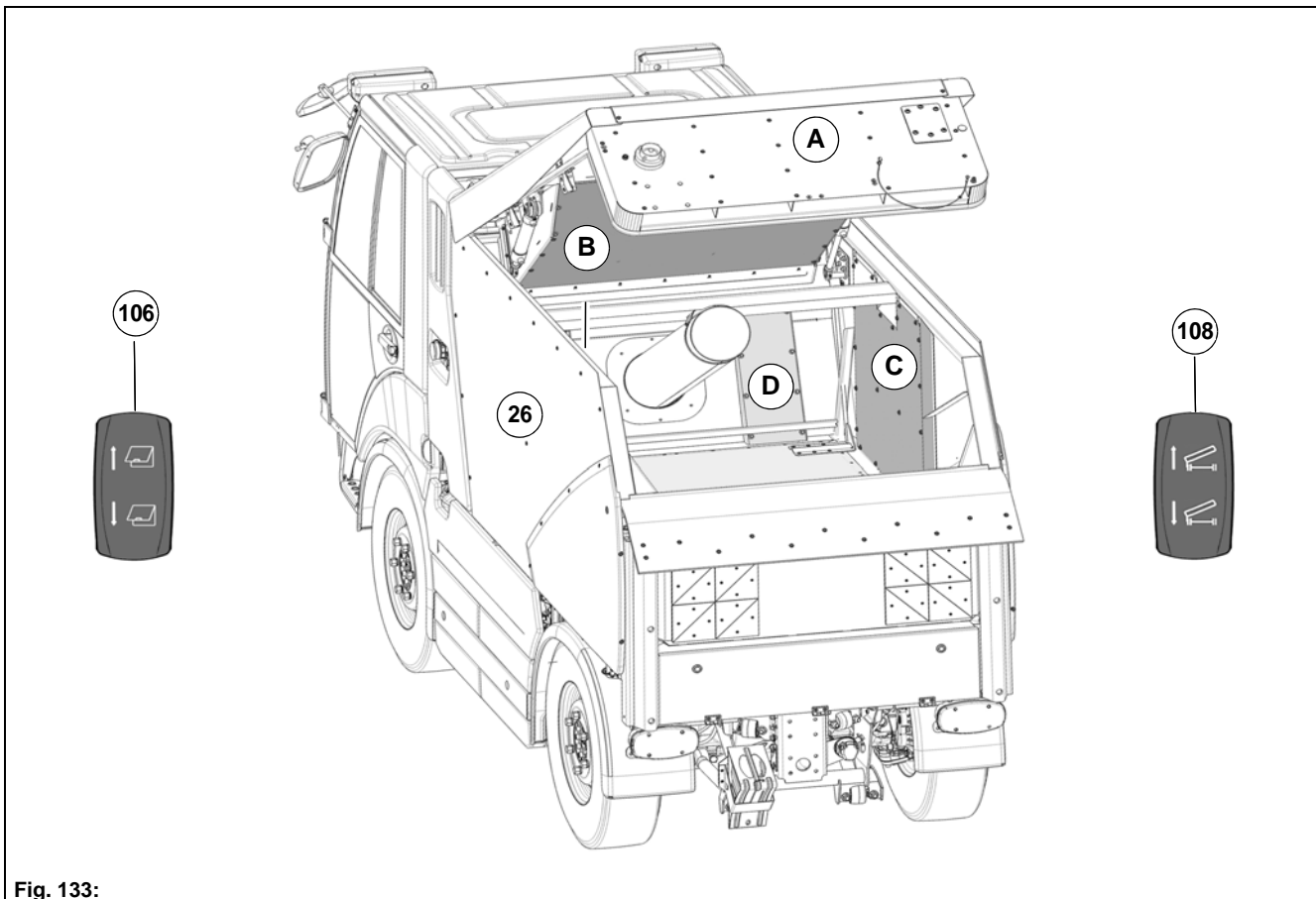

Fig. 133:

Cleaning the circulating water system

Check the circulating water system daily for contamination and clean as required. Before cleaning the circulating water system:

- Empty the dirt hopper, see page 152.
 - Clean the dirt hopper, see page 156.
1. Raise the dirt hopper with the tip switch **Fig. 134-108** and lower it onto the safety strut, see page 222.
 2. Unlock the sump valve **Fig. 134-A** with the lock **Fig. 134-B**. Press the lever forwards and inwards, see position **Fig. 134-I**.
 3. Raise the dirt hopper with the tip switch **Fig. 134-108** up into its end position.
 4. Remove any dirt under the opened sump valve using a water hose.
 5. Lower the dirt hopper and lock the sump valve again. Pull the lever forwards and outwards, see position **Fig. 134-II**.
 6. After cleaning, check the circulating water system, see page 158.

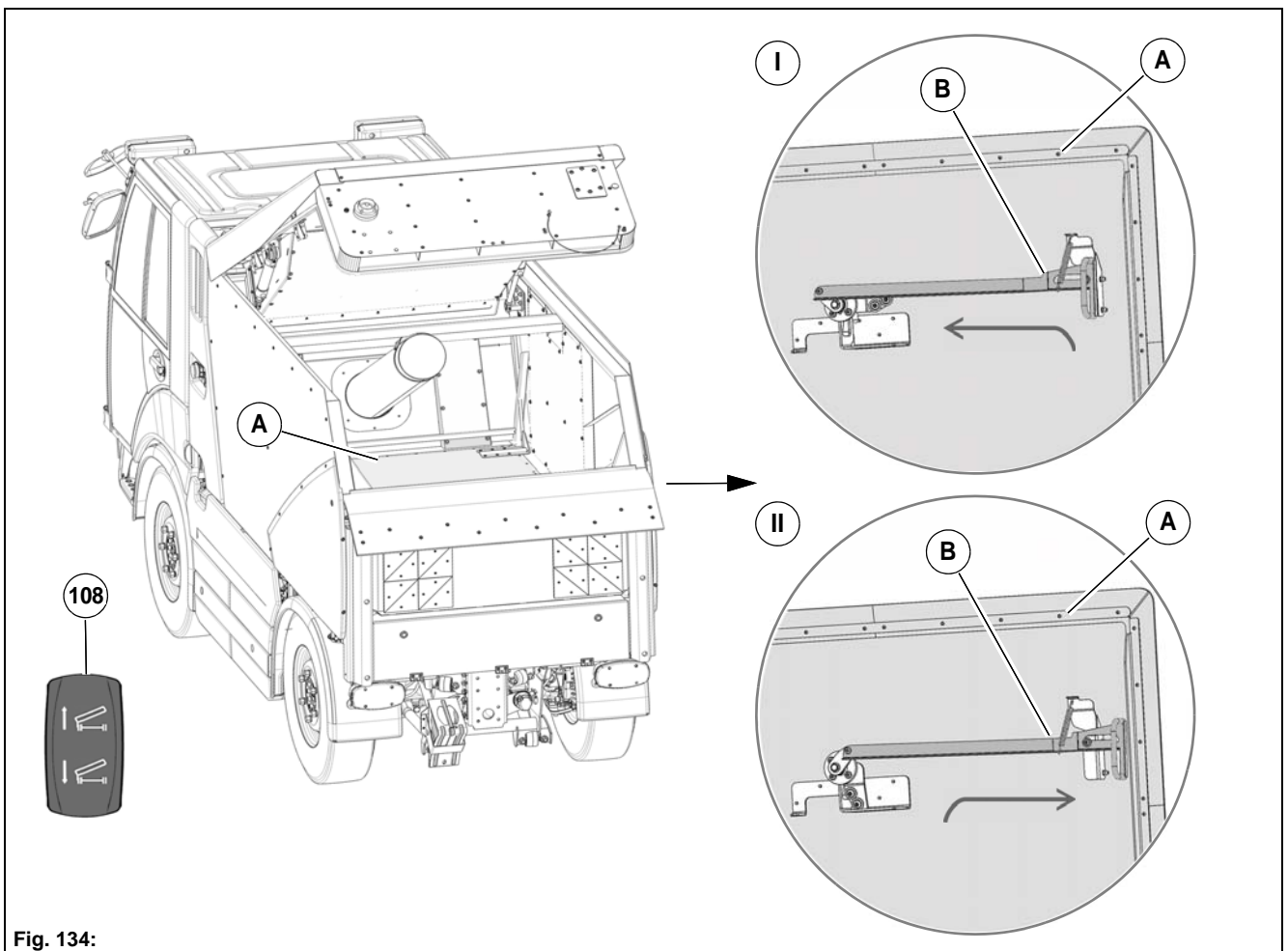

Fig. 134:

Checking the circulating water system

1. Fill the dirt hopper with circulating water, see page 142.
2. Actuate the switch **Fig. 135-81** for the circulating water valve.
3. The circulating water must escape from the suction mouth when the ignition is switched on. If this is not the case, additionally flush the hoses of the circulating water system.

Flushing the hoses of the circulating water system

1. Open the Geka coupling **Fig. 135-A** clockwise. Open the circulating water valve with the switch **Fig. 135-81**.
2. Connect the water hose to the Geka coupling **Fig. 135-A** and flush the circulating water hose to the suction mouth and to the drain hose.
 - Lever **Fig. 135-C** horizontal = flush hose to the suction mouth
 - Lever **Fig. 135-C** vertical = flush hose to the drain hose



Note

After cleaning, set the lever **Fig. 135-C** back to the horizontal position!

3. Connect the water hose to the Geka coupling **Fig. 135-B** and flush the circulating water hose to the dirt hopper.
4. Raise the dirt hopper with the tip switch **Fig. 135-108** up into its end position and empty it.
5. Close the Geka coupling again and rinse the inside of the dirt hopper using a water hose.
6. Lower the dirt hopper again, close the dirt hopper flap and actuate the switch **Fig. 135-81** for the circulating water valve.

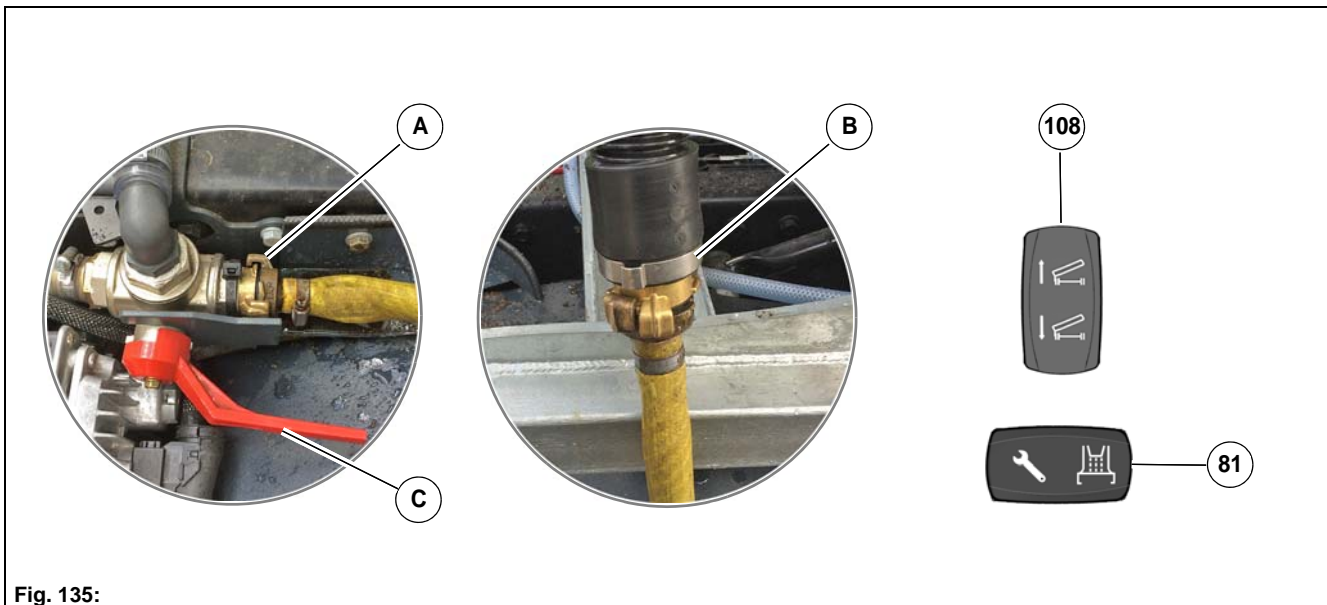

Fig. 135:

4 Technical data

4.1 Engine

Name	Unit	Value
Manufacturer		VM-Motori
Type		VM R754 Euro VI with maintenance-free particle filter and SCR system
Displacement	cm ³	2970
Output 2600 rpm	kW	80
Max. torque at 1100 rpm	Nm	420
Fuel		Diesel
Tank volume	litre	65
AdBlue tank volume	litre	15

4.2 Driving speeds and inclination values

Name	Unit	Value
Transport mode, forwards/reverse	km/h	62/25
Work mode, forwards/reverse	km/h	15/15
Offset mode, forwards/reverse	km/h	20
Gradability (with standard equipment) (at m=6000 kg each)	%	19 % with 225/75 R16 17 % with 285/65 R16

4.3 Tyres

	Standard tyres	Special tyres		
Tyre size	225/75 R16C	225/75 R16C	285/65 R16C	
Tread type	M&S	Winter	All-season tyres (M&S)	
Load index	121/120 R	121/120 R	128 N	128 N
Rim size	6J x 16H2	8J x 16H2	8J x 16H2	
Wheel offset	70 mm	70 mm	60 mm	
Perm. wheel load ¹⁾	1600 kg	1600 kg	1600 kg	1250 kg ³⁾
Max. permissible speed ²⁾	62 km/h	62 km/h	62 km/h	60 km/h ³⁾
Air pressure when loaded, front/rear	6.5 bar/6.5 bar	6.5 bar/6.5 bar	5.0 bar/5.0 bar	3.0 bar/3.0 bar ³⁾
Installation of snow chains	Yes	Yes	No	

1) Wheel loads apply for the specified maximum speeds and tyre pressures

2) Depends on the vehicle, deviations possible according to approvals from tyre manufacturers

3) Specifications are based on separate manufacturer approvals

4.4 Weights and loads

Name	Unit	Value
Empty weight with 2-brush system ¹⁾	kg	3542
Empty weight with 3-brush system ¹⁾	kg	3650
Permissible total weight	kg	6000
Permissible front axle load	kg	3200
Permissible rear axle load	kg	3200

1) Empty weight according to DIN EN 15429-1

4.5 Hydraulic system

Name	Unit	Value
Hydraulic oil (alternative hydraulic oils, See page 179)		HVLP 46
Tank volume	litre	53

4.6 Electrical system

Name	Unit	Value
Nominal voltage	Volt	12
Generator	Ampere	105
Battery		12 V / 55 Ah

4.7 Vacuum sweeping system

Name	Unit	Value
Sweeping unit 2-brush system		
Brush diameter	mm	900
Brush speed	rpm	0 to 120
Sweeping unit 3-brush system		
Brush diameter (pulled brush)	mm	750
Brush diameter (3rd brush)	mm	900
Brush speed	rpm	0 to 120
Dirt hopper		
Suction fan speed	rpm	0 to 3000
Suction duct diameter	mm	200
Dirt hopper nominal volume	litre	2000
Effective volume of dirt hopper (DIN EN 15429)	litre	1710
Effective volume of fresh water tank	litre	340
Circulating water system (including settling tank)	litre	200

4.8 Vehicle dimensions

Name	Unit	2-brush system	3-brush system
Length	mm	4949	4973
Width (with standard tyres)	mm	1330	1330
Height (with standard tyres)	mm	2054	2054
Wheelbase	mm	2190	2190
Tread width (with standard tyres)	mm	1068	1068

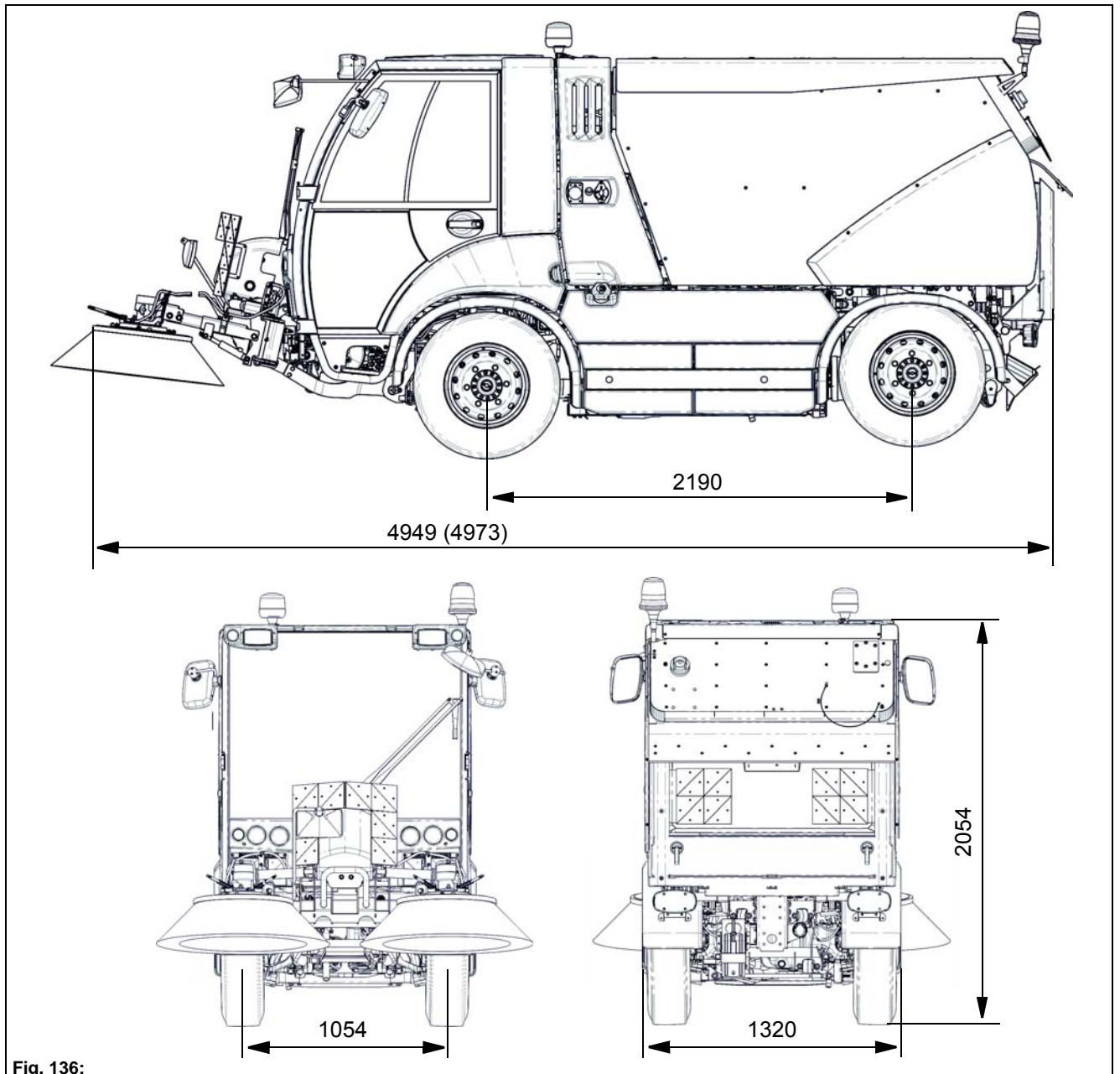

4.9 Noise emission values

Sound pressure level at the workplace to Machinery Directive 2006/42/EC with measuring standard DIN EN ISO 11201						
Conditions	ECO mode Speed 1400 rpm		Standard mode Speed 1700 rpm		MAX mode Speed 2000 rpm	
	L _{pA}	K _{pA}	L _{pA}	K _{pA}	L _{pA}	K _{pA}
Suction fan OFF	73 dB	2.0 dB	74 dB	2.0 dB		
Suction fan to minimum (with sound insulation package)	75 dB*	2.0 dB	76 dB	2.0 dB		
Suction fan to maximum (with sound insulation package)			81 dB	2.0 dB		
Suction fan to minimum (without sound insulation package)	77 dB	2.0 dB	78 dB	2.0 dB		
Suction fan to maximum (without sound insulation package)			83 dB	2.0 dB	83 dB**	2.0 dB

Guaranteed sound power level to Machinery Directive 2000/14/EC with measuring standard DIN EN ISO 3744			
Conditions	ECO mode Speed 1400 rpm	Standard mode Speed 1700 rpm	MAX mode Speed 2000 rpm
	L _{WA} d	L _{WA} d	L _{WA} d
Suction fan OFF	95 dB	96 dB	
Suction fan to minimum (with sound insulation package)	98 dB*	101 dB	
Suction fan to maximum (with sound insulation package)		109 dB	
Suction fan to minimum (without sound insulation package)	101 dB	104 dB	
Suction fan to maximum (without sound insulation package)		112 dB	112 dB**

* Meets the conditions RAL-UZ 59 (Blue Angel eco-label)

** At increased driving speed and sweeping unit with weed brush

4.10 Vibration values

Hand-arm vibrations to Machinery Directive 2006/42/EC with measuring standard DIN EN ISO 5349-1		
Conditions	Vacuum sweeping system	Platform
according to Directive	≤ 2.5 m/s ²	≤ 2.5 m/s ²

Whole-body vibrations to Machinery Directive 2006/42/EC with measuring standard DIN EN ISO 2631-1		
Conditions	Vacuum sweeping system	Platform
according to Directive	≤ 2.5 m/s ²	≤ 2.5 m/s ²

5 Maintenance and servicing

General notes

Before undertaking servicing and maintenance work observe without fail chapter 1 Safety Instructions in this operating manual. Compliance with the maintenance work recommended by us gives you the certainty of always having an operational vehicle available. Daily and weekly maintenance work can be undertaken by a driver trained for this, all further Hako system maintenance work may be undertaken only by trained and qualified personnel.

Please contact your nearest authorised Hako dealer. Any warranty claim is null and void if this is not complied with and damage results. Please always state the serial number in all enquiries and spare parts orders, see the Labels on the vehicle section.

Always have the following work on the vehicle done in an authorised workshop.

- Safety-relevant work
- Maintenance work
- Changes as well as installations and conversions
- Work on electronic components

Hako system maintenance

The Hako system maintenance specifies in single modules the special technical work to be done and the periods of time for the maintenance activities. Parts to be replaced for the individual maintenance tasks are determined and specified in spare parts kits. Hako system maintenance:

- assures the reliable readiness for use of the vehicle (preventive maintenance)
- minimises operating costs, repair costs, costs for maintenance, assures long life and readiness for use of the vehicle.



Note

Compile the maintenance work by reference to the maintenance plans. Example: After 2000 operating hours the maintenance work from the 500, 1000 and 2000 hours maintenance plan must be performed.

General safety instructions – Maintenance and servicing



Danger

- It is not permitted to stand underneath the dirt hopper if it is not secured. Always fit the safety strut whenever working underneath the dirt hopper. There is a danger to life!
- Special caution is required in the area of the front and rear-mounted equipment and attachments. There is a danger to life!
- Perform maintenance and repair work under a jacked up vehicle or attachment only if it is safely and securely supported (hydraulic cylinders, jacks, etc. alone do not secure a jacked-up vehicle). There is a risk of injury!
- Do not perform any welding, drilling, sawing or grinding work on parts of the frame. Damaged parts may be replaced only by your authorised Hako dealer. There is a risk of accidents!
- Adopt measures against erroneous starting and unwanted movement. Engage the parking brake. Switch the engine off and pull out the ignition key. There is a risk of accidents!
- If dismantling safety devices is required in equipping, maintenance and repair work, fit and check the safety devices immediately after completion of the work. There is a risk of accidents!

Attention

- Daily and weekly maintenance work must be done by the operating staff. In all other maintenance work, please contact your nearest authorised Hako dealer.
- Apart from the regular general inspection, the vehicle and the attachments must be maintained at regular intervals according to BGV, D 29 and be checked at least annually for operationally safe condition.
- Spare parts must be original spare parts to guarantee safety.
- Use suitable tools for the cleaning and maintenance work.
- Do not use steam cleaners and high-pressure cleaners (option) for cleaning electrical/electronic components and the engine compartment!
- After cleaning, examine all fuel, engine oil and hydraulic pipes for leaks, abrasion places and damage. Immediately rectify any damage found!
- Always tighten screw connections loosened in maintenance and repair work.

5.1 Maintenance certificate

The following table provides clear information on the maintenance work to be carried out after a certain number of operating hours.

The proper execution of the work must be confirmed by the authorised workshop in the following table.

In order for guarantee and warranty claims to be acknowledged, all maintenance work must be carried out by an authorised workshop and Hako GmbH notified accordingly.

In this context, we refer to the warranty regulations of Hako GmbH.

After operating hours	Maintenance plan	Date	Operating hours status	Company/signature
	Handover			
50	1st inspection			
250	2nd inspection			
500	A			
1,000	B			
1,500	A			
2,000	B			
2,500	A			
3,000	B			
3,500	A			
4,000	B			
4,500	A			
5,000	B			
5,500	A			

Maintenance and servicing

After operating hours	Maintenance plan	Date	Operating hours status	Company/signature
6,000	B			
6,500	A			
7,000	B			
7,500	A			
8,000	B			
8,500	A			
9,000	B			
9,500	A			
10,000	B			
10,500	A			
11,000	B			
11,500	A			
12,000	B			
12,500	A			
13,000	B			

5.2 Maintenance plan

Maintenance plan – daily
Vehicle cleaning <ul style="list-style-type: none"> • Vehicle cleaning as required
Engine <ul style="list-style-type: none"> • Checking engine oil level, replenishing if necessary • Checking coolant level in expansion tank, refilling if necessary • Checking combination radiator and radiator grille for dirt, cleaning with compressed air if necessary • Checking fuel supply, refuelling if required
Steering <ul style="list-style-type: none"> • Checking the steering system for function and leak tightness
Brake <ul style="list-style-type: none"> • Checking the operating and parking brakes for function
Electrical system <ul style="list-style-type: none"> • Checking lighting, work functions, horn, etc.
Vacuum sweeping system
Sweeping unit <ul style="list-style-type: none"> • Checking wear and damage of the sweeping unit • Checking the sweeping level, adjusting if necessary • Fresh water system: Checking the spray nozzles, spray nozzle filter and sieve filter, cleaning if necessary

Maintenance plan – weekly

Vehicle cleaning

- Vehicle cleaning as required

Engine

- Checking engine oil level, replenishing if necessary
- Checking coolant level in expansion tank, refilling if necessary
- Checking combination radiator and radiator grille for dirt, cleaning with compressed air if necessary
- Checking fuel supply, refuelling if required

Vehicle cab

- Checking and the windscreen washing agent level, refilling if necessary
- Checking air conditioning system for function
- Checking heating for function

Steering

- Checking the steering system for function and leak tightness

Brake

- Checking the operating and parking brakes for function
- Checking the brake fluid
- Braking test

Hydraulics

- Checking the hydraulic oil level, refilling if necessary

Wheels

- Checking the wheels (air pressure, tread depth and damage)

Lubrication work at the vehicle

- Carry out all lubrication work according to the lubrication plan, see page 175

Vacuum sweeping system

Sweeping unit

- Checking wear and damage of the sweeping unit
- Checking the sweeping level, adjusting if necessary
- Fresh water system: Checking the spray nozzles, spray nozzle filter and sieve filter, cleaning if necessary

Suction mouth

- Checking wear and damage at the suction mouth
- Checking the suction mouth setting, adjusting if necessary
- Checking the suction hose for wear and seating
- Checking the seal between suction duct and dirt hopper
- Checking the coarse material flap on the suction mouth

Dirt hopper

- Checking the circulating water system incl. settling tank
- Checking the dirt hopper for soiling
- Checking the impact plate for wear and damage, changing if required

Lubrication work at the vacuum sweeping system

- Carry out all lubrication work according to the lubrication plan, see page 175

Maintenance plan – once after 50 operating hours

Engine

- Changing engine oil, changing engine oil filter
- Replacing the fuel filter
- Checking coolant hoses and radiator
- Checking coolant level in expansion tank, refilling if necessary
- Checking combination radiator and radiator grille for dirt, cleaning with compressed air if necessary
- Checking engine bearings for damage and cracks
- Checking V-ribbed belts of the generator drive, belt tensioner and idler pulleys
- Checking generator for soiling and cleaning if required
- Checking the exhaust system for function and tightness
- Checking the fuel pipes for function and tightness
- Checking air suction pipe for function and tightness

Vehicle control

- Reading and evaluating the service information of the vehicle control system and removing faults if necessary
- Checking the software status, updating if necessary

Electrical system

- Checking horn, lighting and working functions
- Checking cabling for abrasion points and damage
- Checking battery charge condition, cleaning and greasing battery poles

Hydraulics

- Changing the return filter
- Checking the hydraulic oil level, refilling if necessary
- Checking the lifting cylinder of the front power lift for function and tightness
- Checking hydraulic pipes for function and tightness

Chassis and axles

- Changing gearbox oil in the differential gear and reduction gear
- Changing gearbox oil between drive motor and transfer gearbox
- Checking axle suspension, springs, shock absorbers and cardan shafts
- Checking all screw connections for firm seat

Steering

- Checking the steering system for function and leak tightness

Brake

- Checking the operating brake for function
- Checking the brake fluid
- Checking the brake hoses for damage
- Checking the parking brake for function

Vehicle cab

- Checking air conditioning system for function
- Checking heating for function
- Checking window washing agent

Wheels

- Checking the wheels (air pressure, tread depth and damage)
- Retightening the wheel bolts

Lubrication work at the vehicle

- Carry out all lubrication work according to the lubrication plan, see page 175

Vacuum sweeping system

Sweeping unit

- Checking wear and damage
- Checking the sweeping level, adjusting if necessary
- Checking the lifting cylinder and hydraulic pipes for function and tightness
- Checking the spray nozzles, spray nozzle filter and sieve filter of the water system, cleaning if necessary

Suction mouth

- Checking wear and damage
- Checking the suction mouth setting, adjusting if necessary
- Checking the coarse material flap and suction mouth lift for function and damage
- Checking the suction hose for wear and seating
- Checking the seal between suction duct and dirt hopper

Dirt hopper

- Checking the suction fan for speed and contamination
- Checking the lifting cylinder and hydraulic pipes for function and tightness
- Checking the seals of the hopper lid for tightness and damage
- Checking the dirt hopper hand pump for function

Lubrication work at the vacuum sweeping system

- Carry out all lubrication work according to the lubrication plan, see page 175

Vehicle maintenance plan – once after 250 operating hours

Engine

- Changing engine oil, changing engine oil filter
- Checking coolant hoses and radiator
- Checking coolant level in expansion tank, refilling if necessary
- Checking the radiator grille for dirt, cleaning with compressed air if necessary
- Checking engine bearings for damage and cracks
- Checking V-ribbed belts of the generator drive, belt tensioner and idler pulleys
- Checking generator for soiling and cleaning if required
- Checking the exhaust system for function and tightness
- Checking the fuel pipes for function and tightness
- Checking air suction pipe for function and tightness

Vehicle control

- Reading and evaluating the service information of the vehicle control system and removing faults if necessary
- Checking the software status, updating if necessary

Electrical system

- Checking horn, lighting and working functions
- Checking cabling for abrasion points and damage
- Checking battery charge condition, cleaning and greasing battery poles

Hydraulics

- Checking the hydraulic oil level, refilling if necessary
- Checking the lifting cylinder of the front power lift for function and tightness
- Checking hydraulic pipes for function and tightness
- Checking the hand pump for function

Chassis and axles

- Checking axle suspension, springs, shock absorbers and cardan shafts
- Checking all screw connections for firm seat

Steering

- Checking the steering system for function and leak tightness

<p>Brake</p> <ul style="list-style-type: none"> • Checking the operating brake for function • Checking the brake fluid • Checking the brake hoses for damage • Checking the parking brake for function
<p>Vehicle cab</p> <ul style="list-style-type: none"> • Checking the heating and air conditioning system for function • Checking window washing agent
<p>Wheels</p> <ul style="list-style-type: none"> • Checking the wheels (air pressure, tread depth and damage) • Retightening the wheel bolts
<p>Lubrication work at the vehicle</p> <ul style="list-style-type: none"> • Carry out all lubrication work according to the lubrication plan, see page 175
<p>Vacuum sweeping system</p>
<p>Sweeping unit</p> <ul style="list-style-type: none"> • Checking wear and damage • Checking the sweeping level, adjusting if necessary • Checking the spray nozzles, spray nozzle filter and sieve filter of the water system, cleaning if necessary • Checking the trailing rubber strap at the 3rd brush (3-brush system only)
<p>Suction mouth</p> <ul style="list-style-type: none"> • Checking the suction mouth setting, adjusting if necessary • Checking the coarse material flap and suction mouth lift for function and damage • Checking the suction hose for wear and seating • Checking the seal between suction duct and dirt hopper
<p>Dirt hopper</p> <ul style="list-style-type: none"> • Checking the suction fan for soiling • Checking the impact plate of the hopper lid for wear • Checking the seals of the hopper lid for tightness and damage • Checking the joints and bearings of the hopper lid • Checking the exhaust side of the hopper lid for contamination • Checking the lifting cylinder and hydraulic pipes for function and tightness • Checking the dirt hopper hand pump for function
<p>Lubrication work at the vacuum sweeping system</p> <ul style="list-style-type: none"> • Carry out all lubrication work according to the lubrication plan, see page 175

Maintenance plan – every 500 operating hours (A)

Engine

- Changing engine oil, changing engine oil filter
- Replacing the fuel filter
- Emptying the water trap of the fuel system
- Changing filter insert of the air filter
- Checking coolant hoses and radiator
- Checking coolant level in expansion tank, refilling if necessary
- Checking combination radiator and radiator grille for dirt, cleaning with compressed air if necessary
- Checking engine bearings for damage and cracks
- Checking V-ribbed belts of the generator drive, belt tensioner and idler pulleys
- Checking generator for soiling and cleaning if required
- Checking the exhaust system for function and tightness
- Checking the fuel pipes for function and tightness
- Checking air suction pipe for function and tightness
- Performing service regeneration of the diesel particulate filter. Only vehicles with diesel particulate filters!

Vehicle control

- Reading and evaluating the service information of the vehicle control system and removing faults if necessary
- Checking the software status, updating if necessary

Electrical system

- Checking horn, lighting and working functions
- Checking cabling for abrasion points and damage
- Checking battery charge condition, cleaning and greasing battery poles

Hydraulics

- Checking the hydraulic oil level, refilling if necessary
- Checking the lifting cylinder of the front power lift for function and tightness
- Checking hydraulic pipes for function and tightness

Chassis and axles

- Changing gearbox oil in the differential gear and reduction gear
- Changing gearbox oil between drive motor and transfer gearbox
- Checking axle suspension, springs, shock absorbers and cardan shafts
- Checking all screw connections for firm seat

Steering

- Checking the steering system for function and leak tightness

Brake

- Checking the operating brake for function
- Checking the brake fluid
- Checking the brake hoses for damage
- Checking the parking brake for function

Vehicle cab

- Checking the air conditioning system for dirt
- Cleaning the plate filter in the vehicle cab
- Cleaning the condenser on the rear wall of the vehicle cab with compressed air
- Checking heating for function
- Checking and if necessary refilling the windscreen washing agent level

Wheels

- Checking the wheels (air pressure, tread depth and damage)
- Retightening the wheel bolts

Lubrication work at the vehicle

- Carry out all lubrication work according to the lubrication plan, see page 175

<p>Vacuum sweeping system</p> <p>Sweeping unit</p> <ul style="list-style-type: none"> • Checking wear and damage • Checking the sweeping level, adjusting if necessary • Checking the spray nozzles, spray nozzle filter and sieve filter of the water system, cleaning if necessary <p>Suction mouth</p> <ul style="list-style-type: none"> • Checking the suction mouth setting, adjusting if necessary • Checking the coarse material flap and suction mouth lift for function and damage • Checking the suction hose for damage and seating • Checking the seal between suction duct and dirt hopper <p>Dirt hopper</p> <ul style="list-style-type: none"> • Checking the suction fan for soiling • Checking the suction fan for vibration, checking the bearings if necessary • Checking the impeller for damage and wear, replacing if necessary • Checking the rubber buffer for damage and wear, replacing if necessary • Checking the impact plate of the hopper lid for wear • Checking the seals of the hopper lid for tightness and damage • Checking the joints and bearings of the hopper lid • Checking the exhaust side of the hopper lid for contamination • Checking the lifting cylinder and hydraulic pipes for function and tightness • Checking the dirt hopper hand pump for function <p>Lubrication work at the vacuum sweeping system</p> <ul style="list-style-type: none"> • Carry out all lubrication work according to the lubrication plan, see page 175

<p>Maintenance plan – every 1000 operating hours (B)</p> <p>Engine</p> <ul style="list-style-type: none"> • Changing the V-ribbed belts for the generator drive • Changing the AdBlue filter <p>Hydraulics</p> <ul style="list-style-type: none"> • Checking the hydraulic oil. Taking and sending in a sample • Changing the hydraulic oil filter • Changing the venting filter of the hydraulic oil tank • Checking the hydraulic oil level, refilling if necessary <p>Vehicle cab</p> <ul style="list-style-type: none"> • Changing the plate filter in the vehicle cab <p>Axle</p> <ul style="list-style-type: none"> • Changing gearbox oil in the differential gear and reduction gear

Maintenance plan – additionally every 3000 operating hours

Engine

- Changing the safety cartridge
- Changing the V-ribbed belts for the generator drive, belt tensioner and idler pulleys
- Checking the diesel particle filter, performing service regeneration if necessary
- Changing the coolant (50 % distilled water and 50 % Paraflu UP) at the latest every 5 years. Never drive without coolant additive Paraflu UP, even in warmer climates. The coolant additive increases the boiling point and prevents corrosion in the engine!

Hydraulics

- Changing hydraulic oil

Maintenance plan – additionally every 2 years

Vehicle cab

- Changing the coolant of the air conditioning system

5.3 Lubrication plan

5.3.1 Lubrication work at the vehicle

Check the lubrication points weekly.

Lubricant specification, see Engine/vehicle fluids and lubricants.

Item	Assembly	Name
A	Doors	<ul style="list-style-type: none"> • Door hinges left, right, above and below (4 points)
B	Central lubrication (option)	<ul style="list-style-type: none"> • Fully automatic central lubrication of the vacuum sweeping system

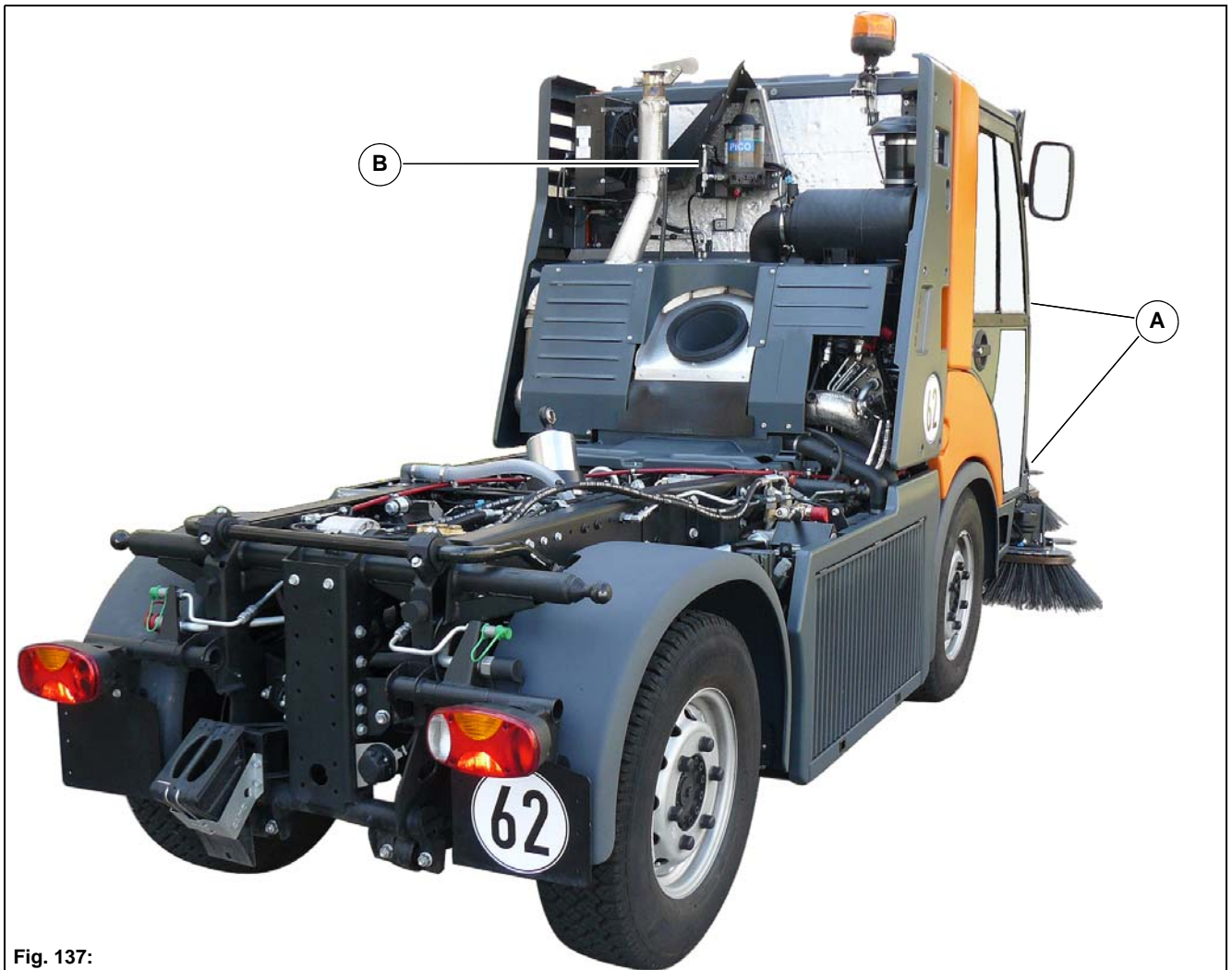

Fig. 137:

5.3.2 Lubrication work at the vacuum sweeping system

Check the lubrication points weekly.

Lubricant specification, see Engine/vehicle fluids and lubricants.

Item	Assembly	Name
A	Sweeping unit 2-brush system	• Swing brush arms to the side (6 pcs.)
B		• Raise/Lower brush arms (6 pcs.)
C		• Brush arms collision protection (2 pcs.)

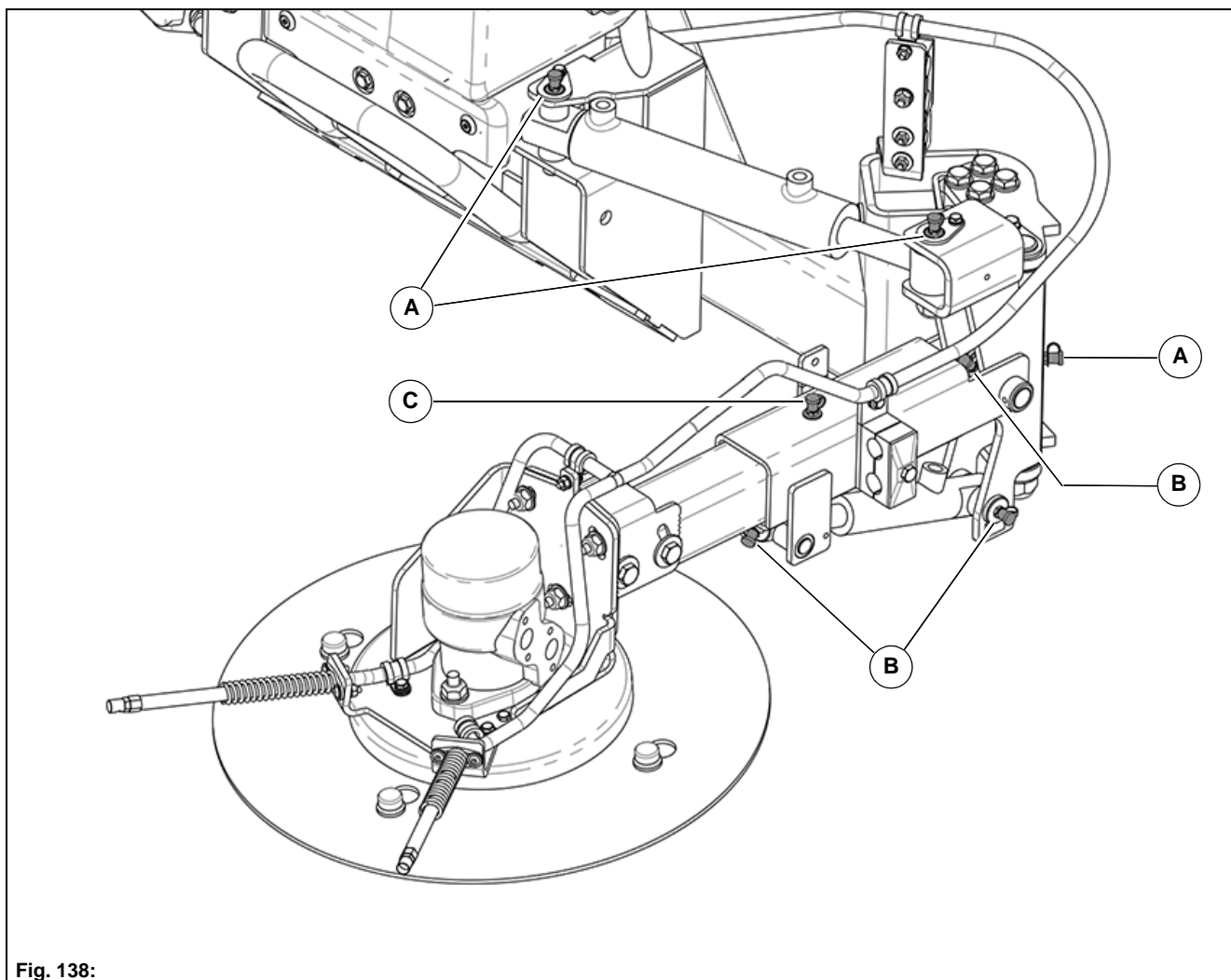

Fig. 138:

Item	Assembly	Name
A	Sweeping unit 3-brush system	• Swing pulled brush arms to the side (2 points)
B		• Raise/Lower pulled brush arms (4 points)
C		• Incline pulled brush arms (2 points)
D		• Swing 3rd brush arm in parallel (8 points)
E		• Swing 3rd brush arm in parallel (2 points)
F		• Raise/Lower 3rd brush arm (4 points)
G		• Incline 3rd brush arm (3 points)
H		• 3rd brush arm collision protection (2 points)

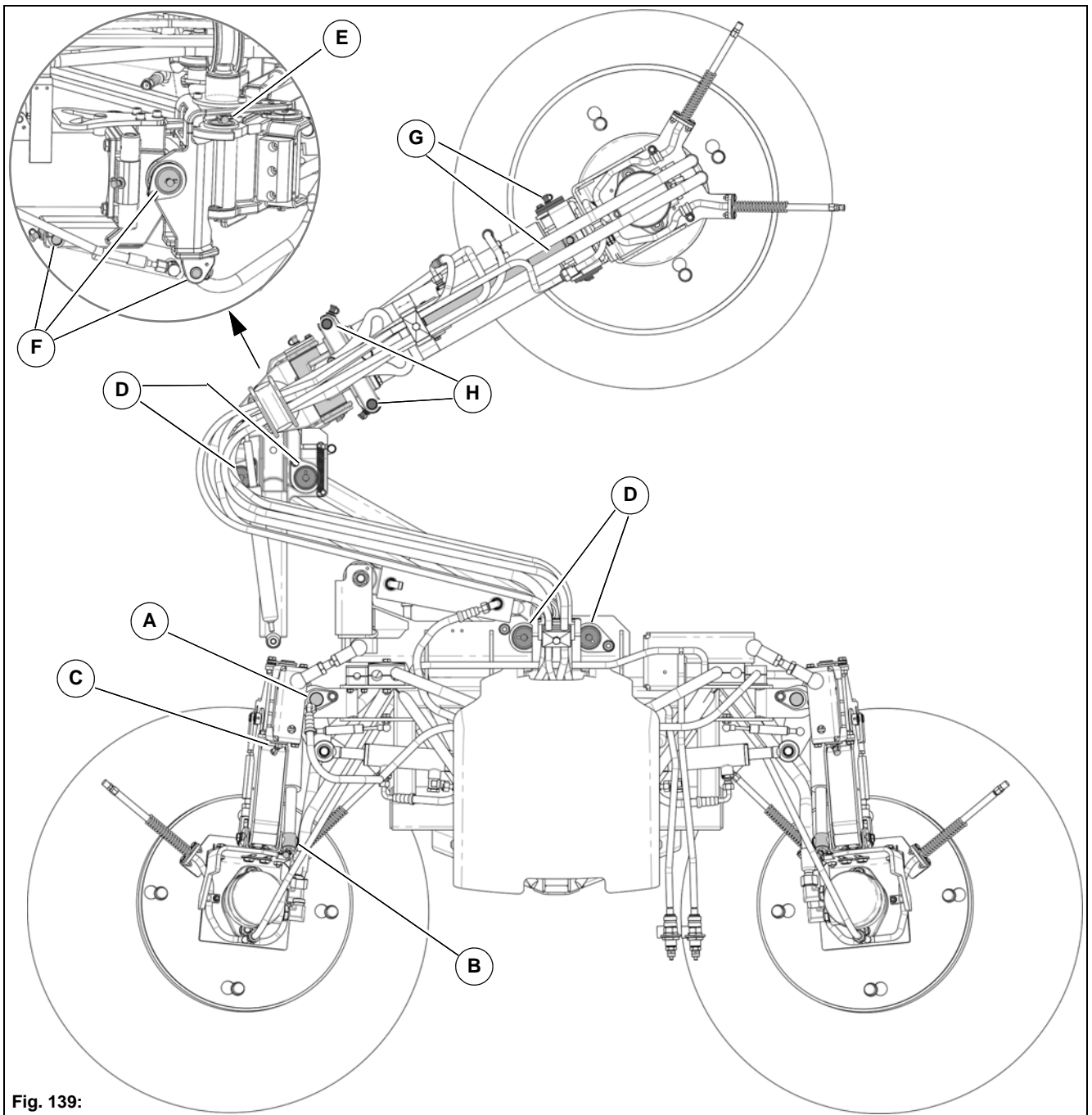

Fig. 139:

Item	Assembly	Name
A	Dirt hopper	• Lift cylinder dirt hopper flap (4 points)
B		• Raising joints (2 points)

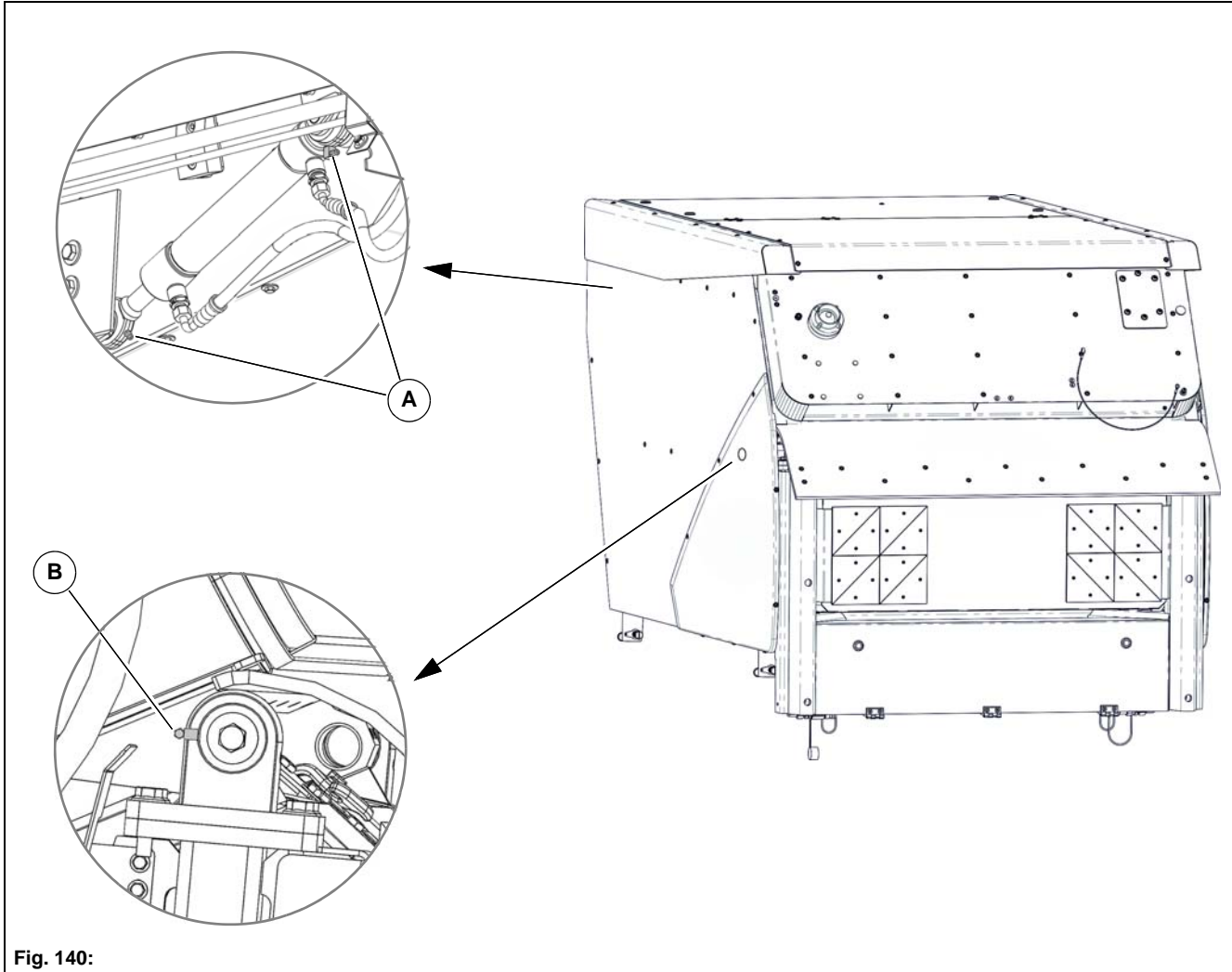

Fig. 140:

5.4 Engine/vehicle fluids and lubricants

Component/application	Engine/vehicle fluid	SAE grade Specification	Season/temperature	Filling quantities ¹⁾
Diesel engine/Fuel	Diesel fuel	DIN EN 590, min 49 CZ	Year-round	66 litres
Diesel engine/AdBlue	Urea solution	ISO 22241 or DIN70070	Year-round	15 litres
Diesel engine/Lubrication	Engine oil	SAE10W-40 ACEA E6/API CJ-4 e.g. Focus/ Motorex	Year-round	9.5 litres
Diesel engine/Cooling	Coolant	Water and Paraflu UP Mixing ratio 1:1	Year-round	16 litres
Drive, steering and work hydraulics ³⁾	Hydraulic oil HLVP 46	DIN 51524, Part 3	Year-round	Tank volume at sight glass max. marking 53 litres, total volume approx. 75-80 litres
	Ester-based biodegradable oil (Panolin HLP SYNTH 46)	DIN 51524, Part 3		
Rear axle/Transfer case	Hypoid gearbox oil	SAE 85 W-90 MIL-L-2105; API - GL5	Year-round	0.9 litres
Rear axle/Differential	Hypoid gearbox oil	SAE 85 W-90 MIL-L-2105; API - GL5	Year-round	2.9 litres
Rear axle/Wheel bearing	Roller bearing grease	DIN 51825, KP 2N-20	Year-round	Fill the bearing 50 %
Front axle/Wheel bearing	Roller bearing grease	DIN 51825, KP 2N-20	Year-round	Fill the bearing 50 %
Service brake	Brake fluid	DOT5.1 - FMVSS 116	Year-round	approx. 1 litre
Air conditioning system	Cooling agent	R134a	Year-round	650 g
	Lubricating oil	PAG 100		100 g
Windscreen washer unit	Water and cleaning solution		Year-round (add anti-freeze during the winter)	3 litres
Lubrication points	Grease	DIN 51825, KP 2N-20	Year-round	As required
Battery terminals	Acid-proof grease		Year-round	As required

1) The specified filling quantities are approximative values

2) Above 50 °C there is a risk of ammonia being released

3) Further hydraulic oils upon request

5.5 Accessibility to assemblies

Safety instructions – Protective devices

**Danger**

- It is not permitted to stand underneath the dirt hopper if it is not secured. Always fit the safety strut whenever working underneath the dirt hopper. There is a danger to life!
- Special caution is required in the area of the front and rear-mounted equipment and attachments. There is a danger to life!
- Put the vehicle into service only if all protective devices are attached and in protection position. There is a risk of injury!
- Do not touch any parts such as engine block, cooling system and exhaust system during operation and for some time after. There is a risk of burns!

Assemblies/Units to be serviced are accessed as follows:

Windscreen washer fluid tank

- in the cab

Paper filter for cab heating

- in the cab

Air filter

- behind the cab, right-hand side of the vehicle

Expansion tank for coolant, battery

- behind the cab, left-hand side of the vehicle

Radiator

- right side of the vehicle

Hydraulic tank, return filter for hydraulic oil, fuel tank, AdBlue tank, oil dipstick for engine oil, hand pump at the fuel filter

- left side of the vehicle

AC condenser and dry filter of the air conditioning system

- behind the cab, left-hand side of the vehicle

Brake fluid tank

- left side of the vehicle in the chassis underneath the cab

Filler opening for engine oil

- accessible when the attachment is raised

Engine oil filter, three-phase alternator

- accessible when the attachment is raised and the engine cover is removed

Fuel filter, V-ribbed belt, oil drain screw of the engine oil, pressure filter of the drive pump, axles, brakes

- from underneath the vehicle

5.5.1 Engine cover

Removing engine cover

Observe the Safety instructions – Protective devices, see page 180.

1. Place the vehicle on a level surface and secure it with the parking brake. Switch the engine off and pull out the ignition key. Allow the engine to cool down.
2. If necessary, raise the tipper.
3. Loosen the fastening bolt **Fig. 141-B** and swing up the engine cover **Fig. 141-A** and remove it to the front.
4. Observe the respective safety instructions.
5. Re-install the engine cover after completing maintenance and repair work.

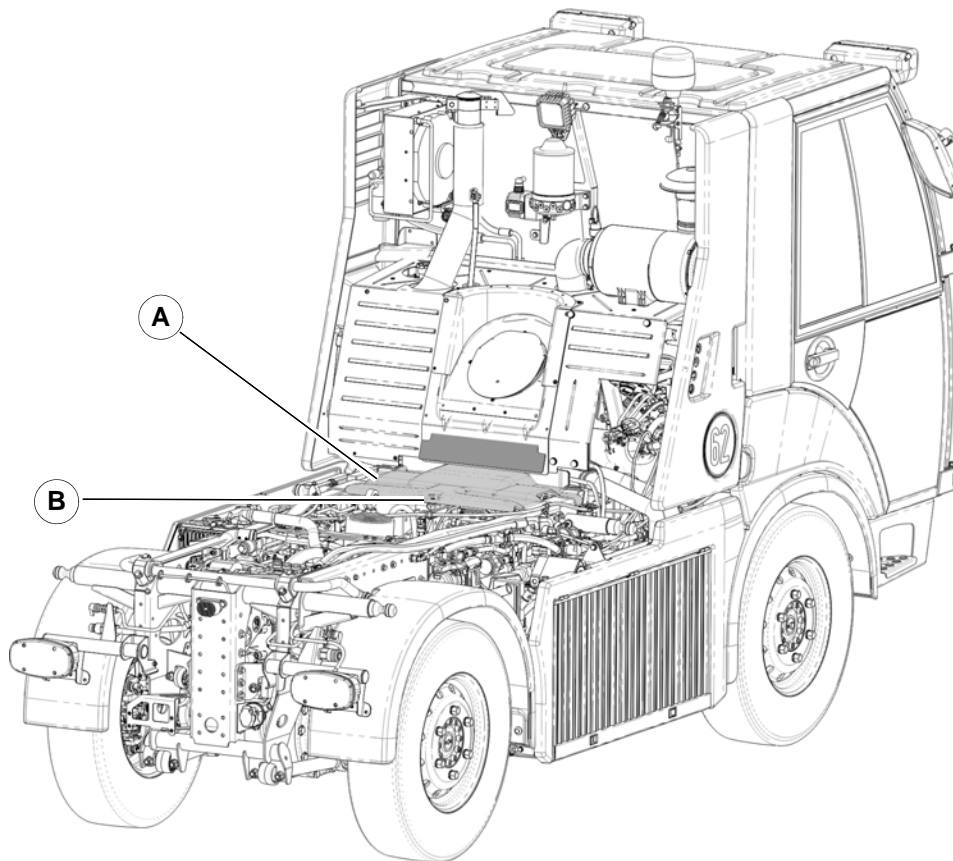

Fig. 141:

5.5.2 Radiator cover

Removing the radiator cover

Observe the Safety instructions – Protective devices, see page 180.

1. Place the vehicle on a level surface and secure it with the parking brake. Switch the engine off and pull out the ignition key. Allow the engine to cool down.
2. Push both locks **Fig. 142-B** simultaneously inwards and swing up the radiator cover **Fig. 142-A**.
3. Secure the swung up radiator cover using a rope loop.
4. Observe the respective safety instructions.
5. Lock the radiator cover again after completing maintenance work.

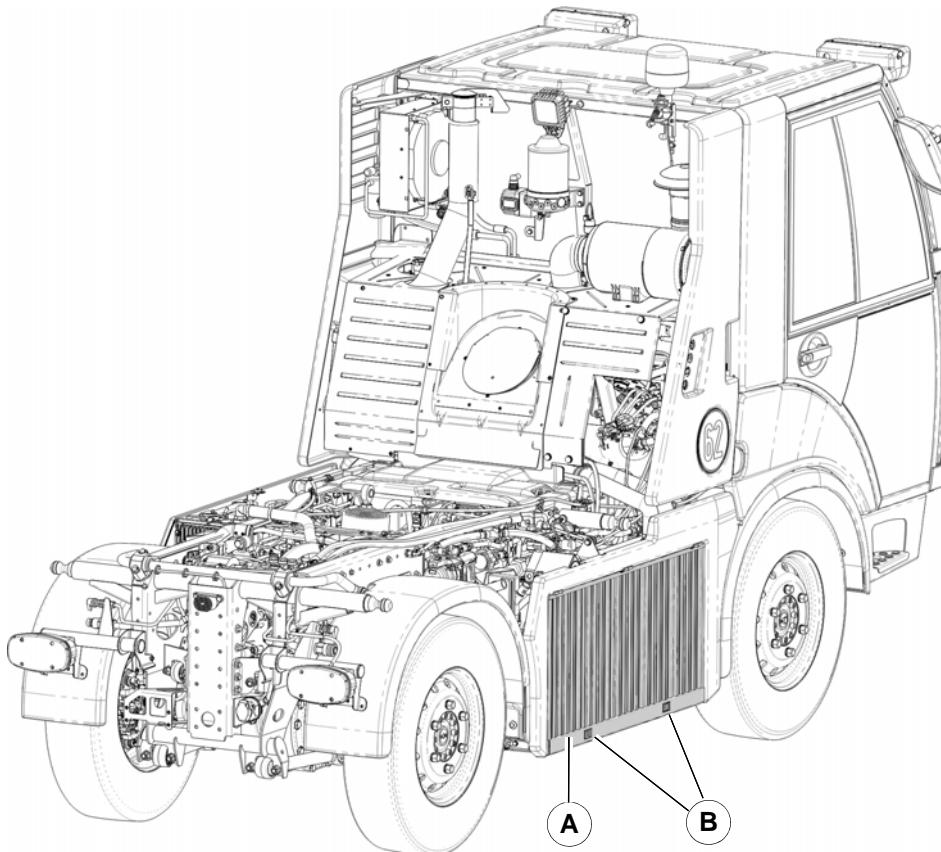

Fig. 142:

5.5.3 Side covers

Observe the Safety instructions – Protective devices, see page 180.

Removing the left side cover

1. Place the vehicle on a level surface and hold it with the parking brake. Switch the engine off and pull out the ignition key. Allow the engine to cool down.
2. Loosen the six fastening bolts **Fig. 143-B** and remove the side cover **Fig. 143-A**.
3. If necessary, raise the tipper.
4. Observe the respective safety instructions.
5. Re-install the side cover after completing maintenance and repair work.

Opening the side flap

1. Place the vehicle on a level surface and hold it with the parking brake. Switch the engine off and pull out the ignition key. Allow the engine to cool down.
2. The side flap **Fig. 143-C** is fixed with magnets and can be opened by hand.
3. Observe the respective safety instructions.
4. Close the side flap again after completing maintenance work.

Removing the right side cover

1. Place the vehicle on a level surface and secure it with the parking brake. Switch the engine off and pull out the ignition key. Allow the engine to cool down.
2. Loosen the six fastening bolts **Fig. 143-B** and remove the side cover **Fig. 143-D**.
3. If necessary, raise the tipper.
4. Observe the respective safety instructions.
5. Re-install the side cover after completing maintenance work.

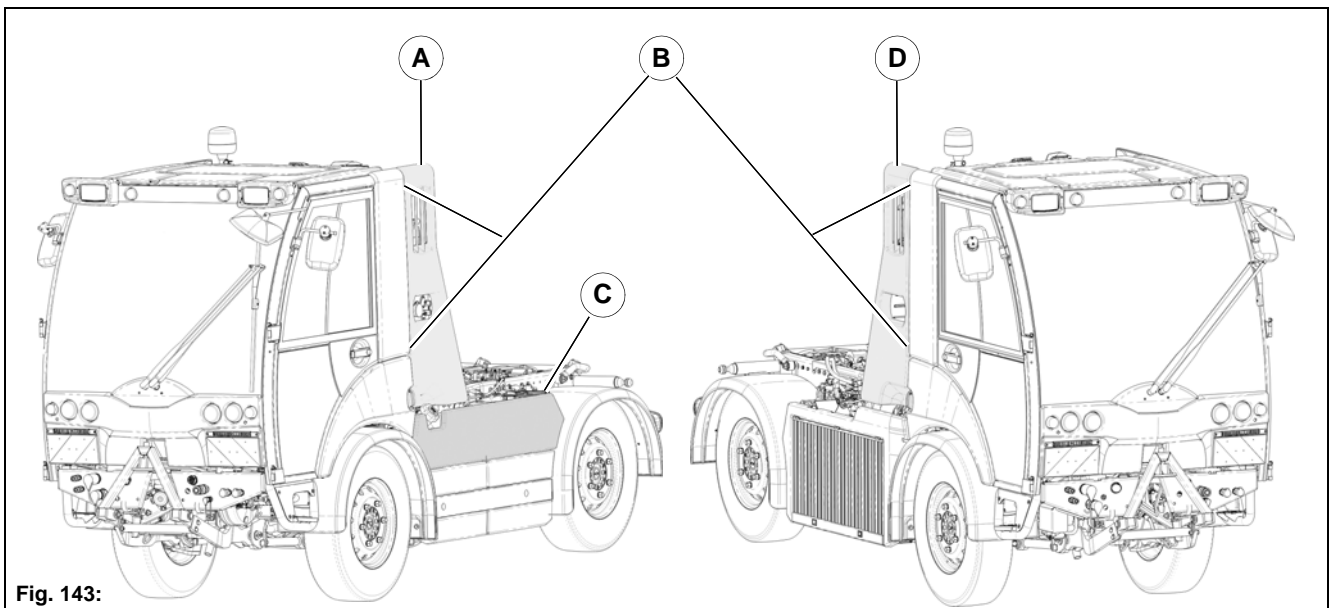

Fig. 143:

5.5.4 Hydraulic hand pump

If the diesel engine fails, the attachment can be raised using the hand pump. The hand pump is located on the right side between the radiator and the rear wheel.

In order to raise the attachment, insert the lever fixed behind the passenger seat in the cab into the holder of the hand pump **Fig. 144-A** and pump the attachment up. To do so, the lever **Fig. 144-B** located at the pump must be set to pump direction "Up".



Note

The attachment cannot be pumped 'down' with the hand pump. In order to lower the attachment, use normal operation via the tip switch **Fig. 144-108** (lowering is also possible when the diesel engine is switched off).

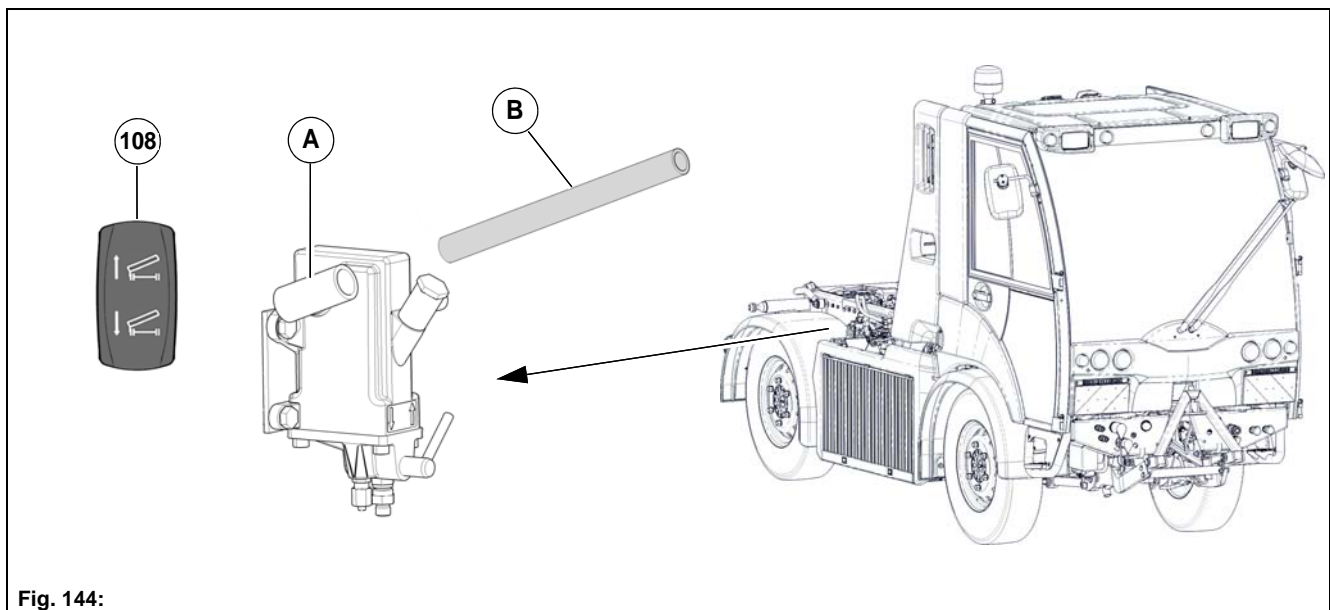

Fig. 144:

5.5.5 EMERGENCY manual control for hydraulics



Danger

If the EMERGENCY manual control is activated with the engine running:

Risk of accidents

- Only use the EMERGENCY manual control to terminate a started operation and make the vehicle ready for operation. Not for continuous operation.

The electromagnetically operated load-sensing control block with EMERGENCY manual control is located behind the vehicle cab on the right-hand side. Inside the vehicle **Fig. 145-G** and outside the vehicle **Fig. 145-H**. This EMERGENCY manual control allows the driver to control the hydraulics manually if the vehicle's electric system is defective.

Valve	Function
A1	Control circuit 2 (move to the left)
A2	Control circuit 2 (move to the right)
B1	Control circuit 3 (close)
B2	Control circuit 3 (open)
C1	Front tool carrier (raise)
C2	Front tool carrier (brush pressure)
D	Front tool carrier (valve)
E	Control circuit 3 (pressure relief)
F	Front tool carrier (floating position)

Operation:

The EMERGENCY manual control is controlled by applying pressure (e.g. by means of a suitable screwdriver) to the centre pins of the solenoids.

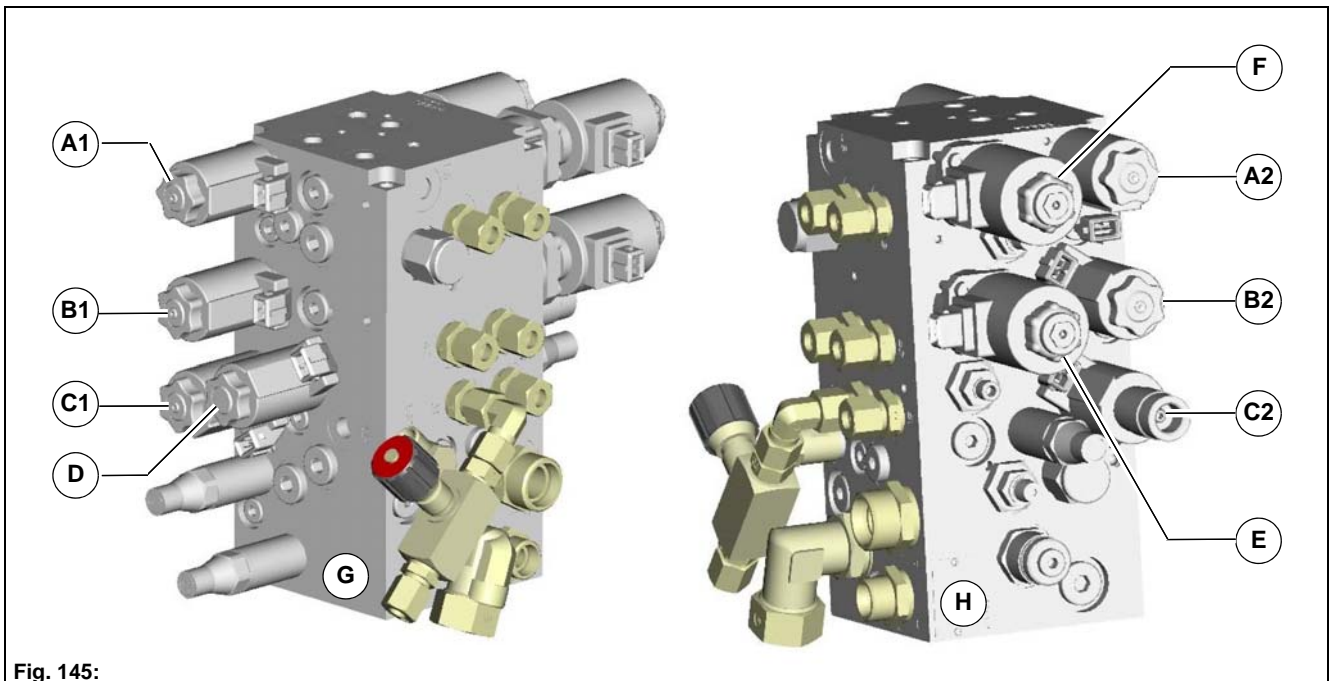

Fig. 145:

5.6 Engine

Safety instructions – Engine



Danger

- Inhaling exhaust gases is injurious to health and can lead to unconsciousness and to death! Never let the engine run in enclosed spaces. Danger to life due to toxic engine exhaust gases.
- Do not touch any parts such as engine block, cooling system and exhaust system during operation and for some time after. Allow the engine to cool down. There is a risk of burns!
- Risk of injury to limbs or of hair or clothing getting caught up in rotating parts. Switch the engine off and pull out the ignition key. There is a risk of burns!

Attention

- If the engine oil pressure warning symbol in the multifunction display lights up with the engine running, there is a risk of engine damage! Stop the vehicle in the safe area. Turn the engine off immediately and check the oil level. Have the cause of the inadequate engine oil pressure removed.
- Excessive or incorrect engine oil may result in engine damage. For this reason:
 - Do not add engine oil to above the MAX marking on the oil dipstick.
 - Engine oil specification, see Engine/vehicle fluids and lubricants.

Environmental danger

- Ensure safe and environment-conserving disposal of operating and auxiliary materials. Take up escaping or spilled operating materials in suitable containers and dispose of them in an environmentally friendly manner.

5.6.1 Checking the engine oil

Check the engine oil level at regular intervals and refill as required. Maintenance intervals according to maintenance plan, see page 167. Observe the Safety instructions – Engine, see page 186.

1. Turn on the engine and let it run until the operating temperature has been reached.
2. Place the vehicle on a level surface and hold it with the parking brake. Switch the engine off and pull out the ignition key. Allow the engine to cool down.
3. The engine oil dipstick **Fig. 146-B** is located on the left-hand side of the vehicle behind the fuel tank **Fig. 146-15** and can be accessed from the outside.
4. Check the engine oil level:
 - If the engine oil pressure warning light **Fig. 146-A** lights up
 - After 10 operating hours or daily
 - With the vehicle on even ground
 - Before starting the engine or
 - No sooner than 5 minutes after switching off the engine
5. Remove the oil dipstick, wipe it with a lint-free cloth and re-insert it up to the stop. Subsequently remove it again and check the oil level.
6. Top up with engine oil as required (at the latest when the oil reaches the MIN marking on the oil dipstick).



Note

Oil consumption can reach up to 0.5 % of the fuel consumption level, depending on driving style and operating conditions. Oil consumption can be even higher during the first operating hours.

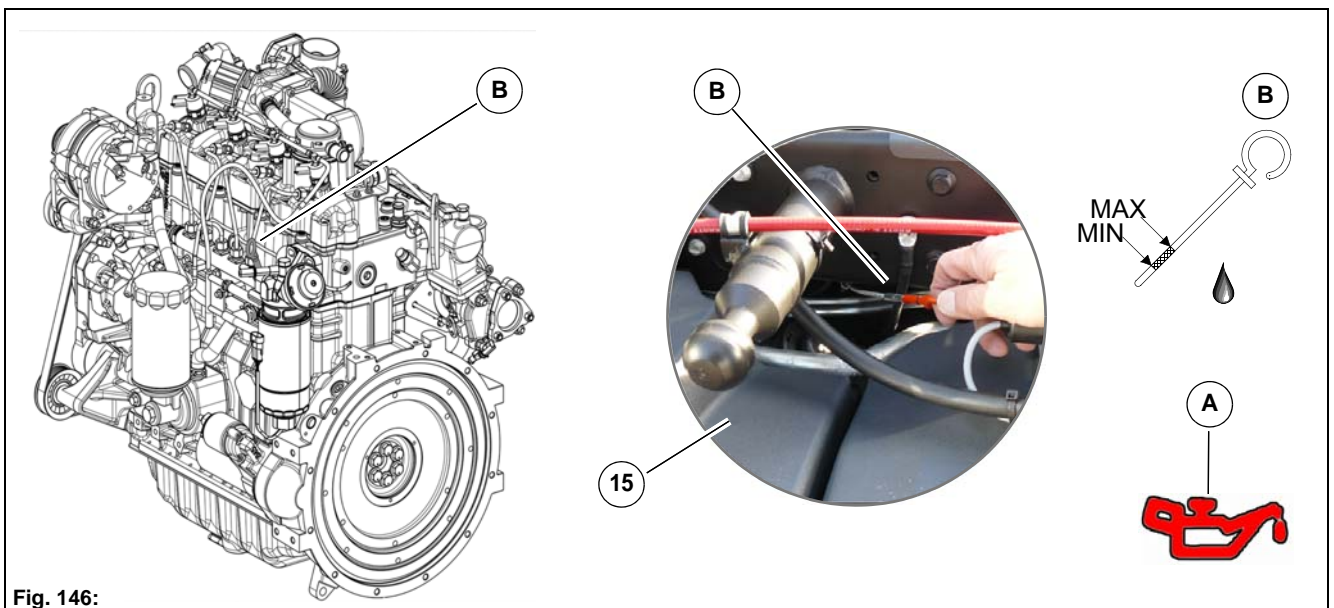

Fig. 146:

5.6.2 Topping up engine oil

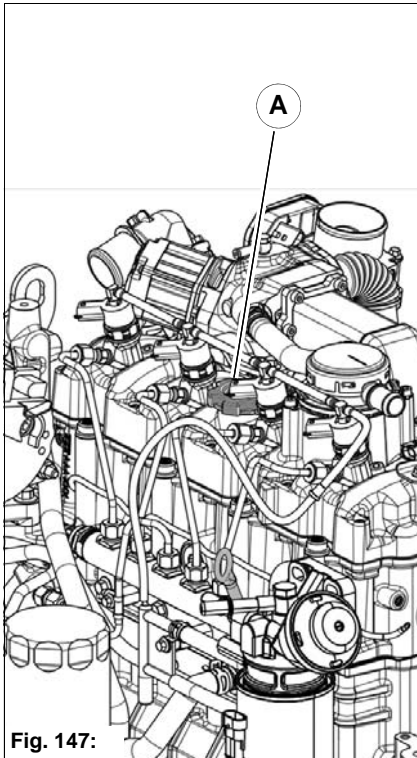

Fig. 147:

Observe the Safety instructions – Engine, see page 186.

1. Place the vehicle on a level surface and secure it with the parking brake.
2. Switch the engine off and pull out the ignition key. Allow the engine to cool down. Observe the safety instructions, see page 186.
3. Remove the engine cover and clean the area around the filler cap **Fig. 147-A** with a lint-free cloth.
4. Open the filler cap and top up engine oil with a suitable oil can. Engine oil specification, see page 179.
5. Wait a few minutes until all the engine oil has run into the oil sump and check the oil level. Top up if necessary and check the oil level again.
6. Close the filler opening again with the filler cap **Fig. 147-A**.
7. Push the oil dipstick back to the stop.
8. Completely remove any spilt engine oil from the engine.

5.7 Fuel system

Safety instructions – Fuel system



Danger

- Risk of fire! Diesel fuel is flammable! Take the utmost care when handling fuel. Never refuel close to naked flames or ignitable sparks. Do not smoke during fuelling. Switch off the engine, pull out the ignition key and engage the parking brake before fuelling. Do not refuel in enclosed spaces. Keep the vehicle clean to reduce the risk of fire. When working on the fuel system, ensure that everything is extremely clean.
- Risk of scalding! Due to the high fuel pressures in the injection system, the fuel can reach higher temperatures, especially when the fuel level in the fuel tank is low.
- The diesel particle filter and the SCR catalytic converter get very hot. Risk of fire and burns!

Attention

- The vehicle cannot be operated with PME fuels (vegetable oil methyl ester). PME fuels have not been tested or approved by Hako GmbH and could impair the safety of the vehicle. Hako GmbH is not liable for damage resulting from this misuse. Use only commercially available diesel fuel to refuel the vehicle. Otherwise, the fuel system will be damaged or reliable diesel particle filter regeneration will no longer be guaranteed. Operation with rape seed oil or biodiesel fuel (RME/ PME) or vegetable oil is not permitted.
- Do not start the vehicle when the fuel tank is empty. This may damage the rail pressure system. Never let the fuel tank run dry. Always refuel the vehicle in good time. If the fuel tank has run dry, bleed the fuel system before starting. Have this done by an authorised workshop!
- If petrol or supergrade petrol was accidentally used for refuelling, the engine must not be started, as damage could otherwise occur. Have the fuel system drained by an authorised workshop with consideration of the environmental regulations and fill again with diesel fuel.
- Fuel additives (for improving flow) and similar agents must not be added to the diesel fuel.
- The use of diesel fuels with high sulphur content can considerably reduce the service life of the diesel particle filter. Ask your authorised workshop for information on the countries in which high concentrations of sulphur are found in diesel fuel.

Environmental danger

- Ensure safe and environment-conserving disposal of operating and auxiliary materials. Take up escaping or spilled operating materials in suitable containers and dispose of them in an environmentally friendly manner.

5.7.1 Refuelling

General information

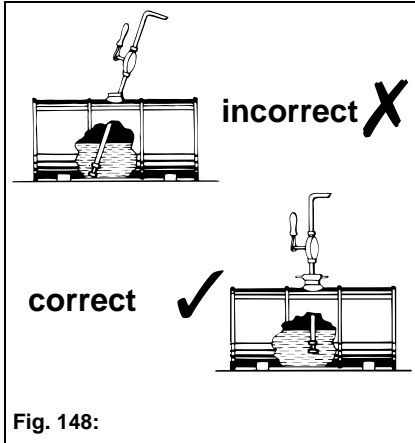

Observe the Safety instructions – Fuel system, see page 189.

Fuel pumps

If possible, only refuel from stationary fuel pumps. Fuel from drums or canisters is usually contaminated.

Even the smallest particles of dirt can cause

- Increased engine wear.
- Malfunctions in the fuel system.
- Reduced effectiveness of the fuel filters.

Refuelling from drums

If refuelling from drums cannot be avoided, note the following points, see figure:

- Drums should neither be rolled nor tilted before refuelling.
- Protect the drum pump intake manifold opening with a fine-mesh filter.
- Immerse the drum pump intake manifold opening down to max. 15 cm above the floor of the drum.
- Only fill the tank with refuelling aids (funnels or filler pipes) with integrated microfilter.
- Keep all refuelling containers clean at all times.

Refuelling diesel

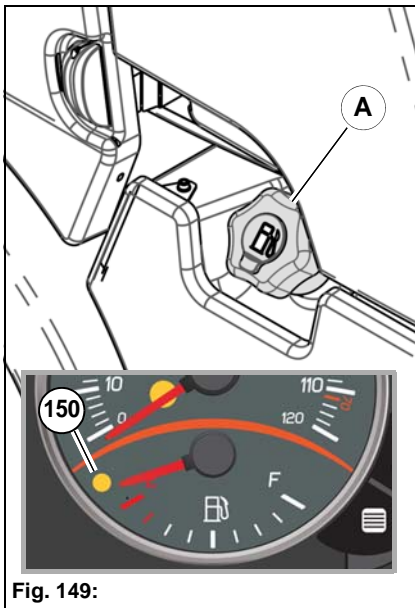

Observe the Safety instructions – Fuel system, see page 189.

The diesel tank is located on the left-hand side of the vehicle behind the vehicle cab. If the warning light **Fig. 149-150** lights up in the indicating device, diesel must be refuelled.

1. Unlock and open the filler cap **Fig. 149-A**.
2. When refuelling, immerse the pump nozzle as far as possible into the tank to prevent diesel fuel from splashing or spilling out.
3. After refuelling, replace the tank lock and turn it to the right until it locks into place with an audible click.
4. Close and lock the tank lock.

5.8 Exhaust gas purification system

Safety instructions – Exhaust gas purification system



Danger

- Do not touch any parts such as engine block, cooling system and exhaust system during operation and for some time after. There is a risk of burns! Allow the engine to cool down.
- The diesel particle filter and the SCR catalytic converter get very hot. Risk of fire and burns!
 - Do not reach into the area of the exhaust outlet. Keep children and other persons away from this area.
- When operating the vehicle, make sure that no easily inflammable materials are in the direct vicinity of the exhaust system, especially the exhaust pipe.
- When parking the vehicle while the engine is running, make sure that no inflammable or combustible materials (e.g. paper, dry grass, straw, wood, wooden building materials, oil, fuels, etc.) are in the direct vicinity of the exhaust outlet.
- Do not park the vehicle in high dry grass. Never use additional underbody sealant or anti-corrosive agents for exhaust pipes, heat shields or the diesel particle filter. These could ignite when the engine is hot.

Attention

- If the diesel particulate filter in the multifunction display lights up red, the vehicle engine must be switched off immediately. Serious engine damage can be caused if this is not complied with.
- Use only commercially available AdBlue to refuel the vehicle. Otherwise, the exhaust system will be damaged or reliable cleaning will no longer be guaranteed. Only use AdBlue as per ISO 22241 or DIN 70070.
- Do not dilute AdBlue and do not add additives.
- In the event of malfunctions and damages at the exhaust gas purification system resulting from the application of AdBlue that does not meet the specifications and non-observance of this information, no warranty claims will be acknowledged.
- If exposed to intense heat above 50 °C (e.g. due to sunshine) over a longer period of time, ammonia may be released resulting in a pungent smell. Do not inhale escaping vapours when opening the tank. Ammonia vapours in this concentration are, however, not detrimental to health.
- Wipe the surfaces of components which might come into contact with AdBlue, e.g. when topping up, immediately with water.
- When refuelling AdBlue, always observe the information on topping up volumes as the tank could burst due to overfilling and low outside temperatures.
- The vehicle is equipped with an AdBlue preheating system which ensures operation of the exhaust gas purification system at temperatures below -11 °C. If the vehicle is used in regions where outside temperatures are always below -10 °C, install special measures to ensure correct AdBlue dosage and trouble-free engine operation.
- When refuelling using a pump nozzle with automatic shutoff, there is no risk of overfilling as the supply is stopped automatically when the max. permissible tank volume has been reached. When refuelling from canisters, always observe the topping up volume and avoid overfilling.

Environmental danger

- Ensure safe and environment-conserving disposal of operating and auxiliary materials. Take up escaping or spilled operating materials in suitable containers and dispose of them in an environmentally friendly manner.

5.8.1 Diesel particle filter

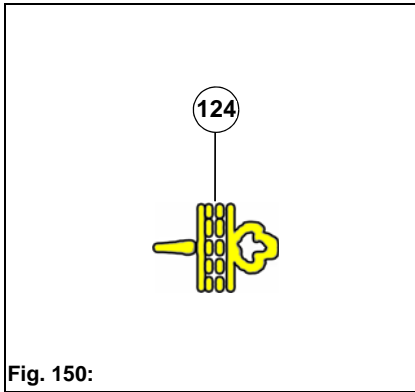

Fig. 150:

Observe the Safety instructions – Exhaust system, see page 191.

The diesel particulate filter filters damaging soot particles from the engine exhaust gases. The engine control system automatically initiates cleaning of the diesel particulate filter. If the diesel particulate filter telltale

Fig. 150-124 lights up in the indicating device, the diesel particulate filter has reached a critical load condition and must be regenerated.

- Regeneration of the diesel particulate filter was not possible during the previous engine operation (e.g. extreme short-distance operation).
- To reliably regenerate the diesel particulate filter, operate the vehicle for at least 15 minutes in drive or working operation (operation of implements/attachments is possible).
The most effective cleaning of the diesel particulate filter occurs when driving continuously and calmly or when in working operation with constant speed and medium load of the engine without extreme load changes.
- The telltale goes out when the particle mass has dropped to an uncritical value.

5.8.2 Refuelling AdBlue

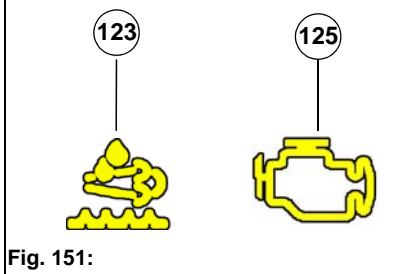
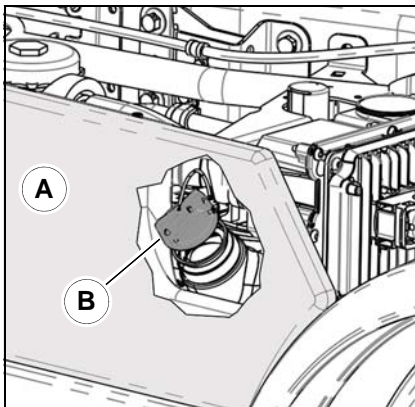

Fig. 151:

Observe the Safety instructions – Exhaust system, see page 191.

The AdBlue tank is located on the left-hand side of the vehicle next to the diesel tank. The tank volume is 15 litres. If the warning light **Fig. 151-151** lights up in the indicating device, AdBlue must be refuelled.

- The warning light **Fig. 151-151** lights up:
 - Residual content = 6.5 litres
- The warning light **Fig. 151-151** lights up, additionally the warning light SCR **Fig. 151-123** lights up:
 - Residual content = 4.5 litres
- The warning light **Fig. 151-151** lights up, additionally the warning light SCR **Fig. 151-123** flashes and the warning light **Fig. 151-125** EOBD/MIL lights up:
 - Maximum vehicle speed is 20 km/h
 - AdBlue tank is empty, refuel approx. 15 litres of AdBlue

1. Swing down the side cover **Fig. 151-A**.
2. Open the filler cap **Fig. 151-B**.
3. When refuelling, immerse the pump nozzle as far as possible into the AdBlue tank to prevent diesel fuel from splashing or spilling out.
4. After refuelling, replace the tank lock and turn it to the right until it locks into place with an audible click.
5. Lock the tank lock and close the filler flap.



Attention

If the two warning lights still light up after refuelling and starting the diesel engine for a second time, there is a malfunction in the SCR system. Inform an authorised workshop!

5.9 Cooling system

Safety instructions – Cooling system



Danger

- The cooling system is under pressure. If the cooling system cap is opened with a hot engine there is a risk of scalding. Allow the engine to cool down.
 - Wait at least 10 minutes after switching off the engine.
 - Wear protective gloves and clothing.
 - Always start by actuating the safety valve in the expansion tank filler cap; to do this, open the filler cap to the first notch and allow the pressure to escape.
- Risk of injury to limbs or of hair or clothing getting caught up in rotating parts. Switch the engine off and pull out the ignition key. There is a risk of injury!
- Never switch on the reversing fan (option) in the vicinity of people or in road traffic. Make sure there are no persons or vehicles in the direct vicinity of the vehicle. Only switch on the reversing fan in open spaces. There is a risk of accidents!

Attention

- Small air bubbles can form when the radiator is filled. Therefore the cooling system must be vented at the same time. Have this done by an authorised workshop!
- Be careful when cleaning the radiator with a high-pressure cleaner or steam jet. The radiator fins are made of 0.1-mm-thick sheet metal and can be easily damaged. Make sure that the nozzle is not closer than 30 cm to the radiator fins.
- The coolant additive and the coolant are detrimental to health. Therefore, store the coolant additive in the original container and take particular care to ensure that it is kept out of the reach of children.
- Dirt on the radiator fins reduces the radiator's heat dissipation capacity. Therefore:
 - Clean the outside of the radiator at regular intervals.
 - In dusty or dirty working conditions, clean more frequently than indicated in the maintenance plans.
- An insufficient coolant level reduces the heat dissipation capacity as well, and can lead to engine damage. Therefore:
 - Check the cooling level at regular intervals, see maintenance plan.
 - If coolant must be added frequently, check the cooling system for leaks and/or seek advice from your authorised workshop.
 - Never fill up with cold water/coolant if the engine is warm.
 - After filling the radiator, test-run the engine and check the coolant level again after switching off the engine.
- Using the wrong coolant can destroy the engine and radiator. Therefore:
 - Coolant specification, see Engine/vehicle fluids and lubricants.
 - Do not use radiator cleaning agents if an antifreeze compound has been added to the coolant, as this causes sludge to form, which can damage the engine.

Environmental danger

- Ensure safe and environment-conserving disposal of operating and auxiliary materials. Take up escaping or spilled operating materials in suitable containers and dispose of them in an environmentally friendly manner.

5.9.1 Checking the coolant level

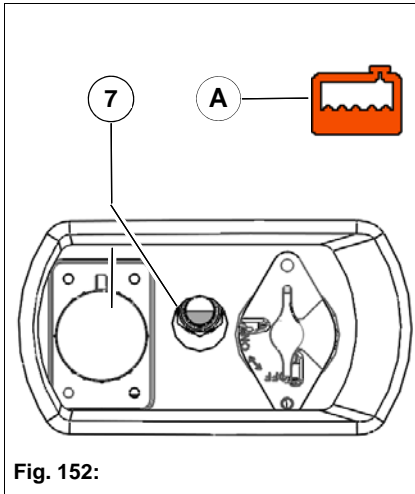

Fig. 152:

Check the coolant level at the sight glass **Fig. 152-7** at regular intervals and refill as required. Maintenance intervals according to maintenance plan, see page 167. The sight glass is located on the left-hand side of the vehicle behind the vehicle cab. The warning symbol **Fig. 152-A** appears in the indicating device if the coolant level is too low.



Note

The coolant prevents frost and corrosion damage and lime deposits and also increases the boiling point of the water. For these reasons, the cooling system must be filled with coolant additive the whole year round. Especially in countries with a tropical climate, the coolant with its higher boiling point contributes to operational safety when the engine is under high load.

Observe the Safety instructions – Cooling system, see page 193.

1. Place the vehicle on a level surface and hold it with the parking brake. Switch the engine off and pull out the ignition key. Allow the engine to cool down.
2. Check the coolant level.
With the engine cooled down, the coolant must be in the middle of the sight glass **Fig. 152-7**. If the engine is warm, it might also be above the middle.
3. If no coolant can be seen in the sight glass or the warning symbol **Fig. 152-A** lights up in the indicating device, coolant must be topped up.

5.9.2 Topping up the coolant

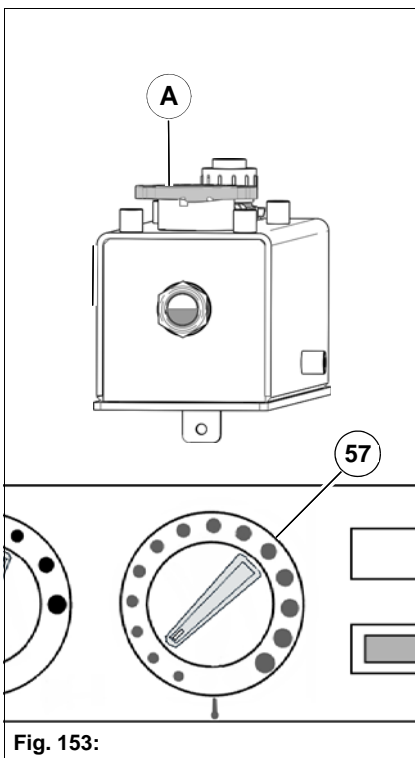

Fig. 153:

Observe the Safety instructions – Cooling system, see page 193.

1. Place the vehicle on a level surface and secure it with the parking brake.
2. Raise the dirt hopper and place it on the safety strut, see page 222.
3. Switch the engine off and pull out the ignition key. Allow the engine to cool down. Observe the safety instructions, see page 193.
4. Cover the filler cap **Fig. 153-A** with a cloth.
5. Gradually unscrew the filler cap carefully up to the stop. Wait until the pressure is even. Press down the filler cap and open completely.
6. Coolant specification, see page 179.
Slowly top up coolant. If the radiator has been topped up to the middle of the sight glass, lock the filler cap again.
7. Turn the rotary switch **Fig. 153-57** up to the stop towards red (warm).
8. Run the engine with increased idle speed for a few minutes.
9. Turn off the engine and check the coolant level again and top up if necessary; observe expansion of the coolant at high temperatures.

5.9.3 Cleaning the cooling system

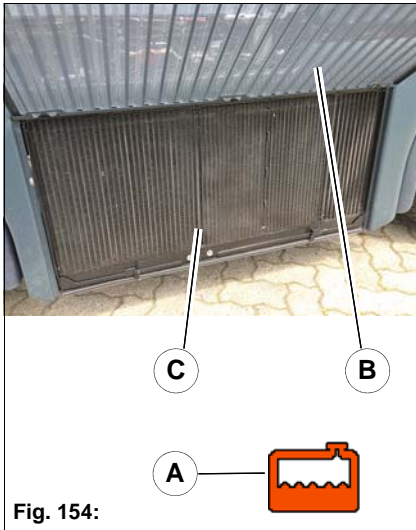

Fig. 154:

Observe the Safety instructions – Cooling system, see page 193.

A slow increase in the coolant temperature is a sign that the cooling system is contaminated. If the coolant temperature is too high, it is signalled by the warning symbol **Fig. 154-A** in the multifunction display. Check the cooler at regular intervals for external contamination and clean as required. Maintenance intervals according to maintenance plan, see page 167.

1. Place the vehicle on a level surface and secure it with the parking brake. Switch the engine off and pull out the ignition key. Allow the engine to cool down.
2. Open the radiator cover **Fig. 154-B**, see page 182.
3. Clean the cooling fins **Fig. 154-C** of the combination cooler located behind with compressed air or water jet.



Attention

Be careful when cleaning the radiator with a high-pressure cleaner or steam jet. The radiator fins are made of 0.1-mm-thick sheet metal and can be easily damaged. Make sure that the nozzle is not closer than 30 cm to the radiator fins.

5.9.4 Cleaning the cooling system with reversing fan (option)

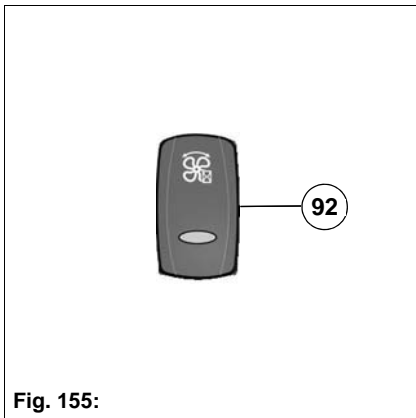

Fig. 155:

Observe the Safety instructions – Cooling system, see page 193.

For special tasks with strong contamination of the radiator, the vehicle can be equipped with a reversing fan in the factory.

Accumulated dust, leaves or grass is/are blown through the radiator grille to the outside when briefly reversing the direction of rotation of the fan drive. The tip switch **Fig. 155-92** for the reversing fan is located in the centre console.

Tip switch – reversing fan	
Press the tip switch briefly on symbol	<ul style="list-style-type: none"> • The direction of rotation is reversed for approx. 15 seconds • The telltale lights up while reversing the direction of rotation
Press the tip switch for longer on symbol	<ul style="list-style-type: none"> • The direction of rotation is reversed for approx. 30 seconds • The telltale lights up while reversing the direction of rotation



Note

The reversing fan (option) does not replace the need for cleaning the radiator at regular intervals. Clean the cooling fins with compressed air or water jet at regular intervals.

5.10 Air filter

Safety instructions – Air filter

**Danger**

- Do not touch any parts such as engine block, cooling system and exhaust system during operation and for some time after. Allow the engine to cool down. There is a risk of burns!

Attention

- We can assume no liability for cleaned filter inserts. Never let the engine run without a filter insert!
- Only replace the safety cartridge, do not clean it! Never let the engine run without safety cartridge!

Environmental danger

- Ensure safe and environment-conserving disposal of operating and auxiliary materials. Take up escaping or spilled operating materials in suitable containers and dispose of them in an environmentally friendly manner.

5.10.1 Checking the cyclone separator

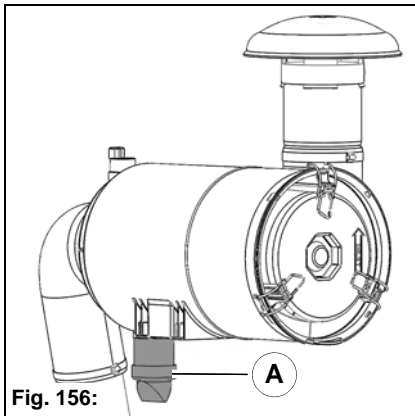

Fig. 156:

Observe the Safety instructions – Air filter, see page 193.

Check the cyclone separator **Fig. 156-A** of the air filter at regular intervals and clean as required. Maintenance intervals according to maintenance plan, see page 167.

1. Place the vehicle on a level surface and secure it with the parking brake. Switch the engine off and pull out the ignition key. Allow the engine to cool down.
2. Remove the right side cover, see page 183.
3. Press the cyclone separator **Fig. 154-C** to the side and remove the dust particles separated from the filter housing.

5.10.2 Cleaning the filter insert

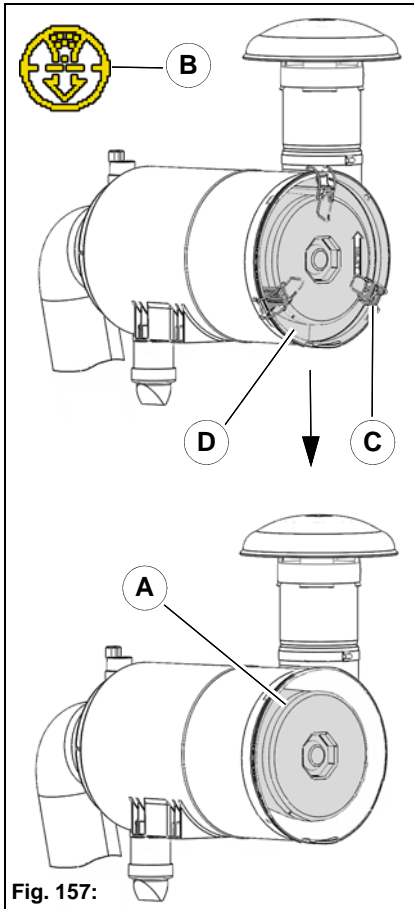

Fig. 157:

Observe the Safety instructions – Air filter, see page 193.

If the filter insert **Fig. 157-A** is soiled, the warning symbol **Fig. 157-B** appears in the multifunction display.

1. Place the vehicle on a level surface and secure it with the parking brake. Switch the engine off and pull out the ignition key. Allow the engine to cool down.
2. Remove the right side cover, see page 183.
3. Open the locks **Fig. 157-C** at the air filter housing and remove and open the flap **Fig. 157-D**.
4. Lift the filter insert and remove it.
5. Tap the filter insert and remove dirt from the air filter housing if necessary.
6. Insert the filter insert and push it downwards.
7. Insert the flap and close the locks at the air filter housing.

5.11 Hydraulic system

Safety instructions – Hydraulic system

	<p>Danger</p> <ul style="list-style-type: none">• Do not touch any parts such as engine block, cooling system and exhaust system during operation and for some time after. Allow the engine to cool down. There is a risk of burns!• Hydraulic oil issuing under high pressure can penetrate the skin and cause severe injuries. Therefore, even with the smallest wounds, consult a doctor since otherwise severe infections can arise! There is a risk of burns! <p>Warning</p> <ul style="list-style-type: none">• Work on the hydraulic system of the vehicle may be done only by persons with special knowledge and experience in hydraulics.• Regularly check all pipes, hoses and screw connections for leaks and external visible damage. Immediately rectify damage and leaks. Oil squirting out can cause injuries and fires. Observe the recommended replacement intervals for hydraulic pipes. With normal requirements 6 years, with increased requirements on safety 2 years!• Do not change over hydraulic pipes! Fittings and the length and quality of the hose line must comply with the requirements. <p>Environmental danger</p> <ul style="list-style-type: none">• Ensure safe and environment-conserving disposal of operating and auxiliary materials. Take up escaping or spilled operating materials in suitable containers and dispose of them in an environmentally friendly manner.
---	--

Safety instructions on using BIO OIL

	<p>Attention</p> <ul style="list-style-type: none">• Use only the BIO hydraulic fluids approved by the Hako GmbH, see Engine/vehicle fluids and lubricants. Use of another not recommended product must be agreed with Hako without fail. In addition, a written guarantee declaration must be obtained from the supplier. This guarantee applies for the case that damage to hydraulic units occurs that is demonstrably attributable to the hydraulic fluid.• Use only BIO oil of the same grade for topping up and oil changing. Clear information about the momentary oil grade used must be placed close to the filler cap! Mixing two BIO oil grades can impair the properties of one grade. Make sure that when the BIO oil is changed, the remaining residual volume of the original hydraulic fluid in the hydraulic system does not exceed 8 % (manufacturer's data).• Do not top up with mineral oil. The mineral oil content should not exceed 2 % by weight to avoid foaming problems and not to impair the biological degradability of the BIO oil.• When running the vehicle with biodegradable oil, the same oil and filter replacement intervals apply as for mineral oil, see Engine/vehicle fluids and lubricants. The condensed water in the hydraulic oil tank must be drained off before the cold season. The water content should not exceed 0.1 % by weight.• All information about environmental protection in this operating manual also applies when BIO oils are used.• If additional hydraulic devices are attached and operated, then operate these with the same BIO oil grades, so that mixing in the hydraulic system is avoided.• In subsequent oil changing from mineral to BIO oil, the hydraulic units must be scavenged completely.
---	--

5.11.1 Checking the hydraulic oil level

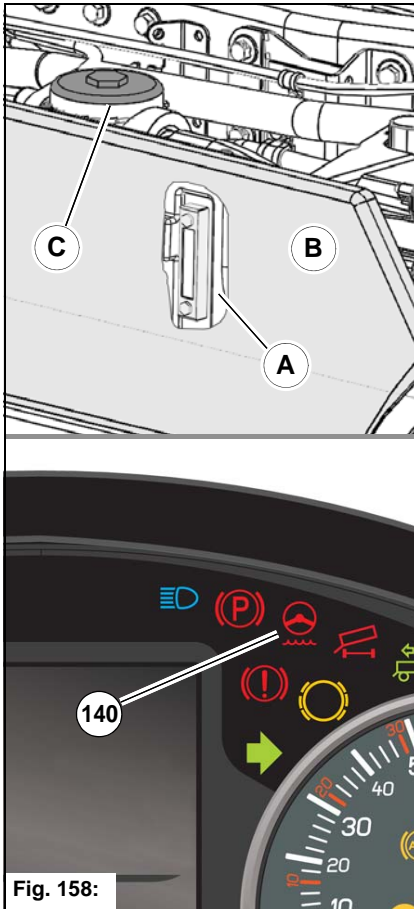

Observe the Safety instructions – Hydraulic system, see page 198.

Check the hydraulic oil level at the sight glass **Fig. 158-A** at regular intervals and top up as required. Maintenance intervals according to maintenance plan, see page 167.



Danger

If the power steering oil level / hydraulic oil level warning light **Fig. 158-140** lights up, this may indicate a failure of the hydraulic steering. There is a risk of accidents!

- Reduce the vehicle speed immediately.
- Drive slowly to an authorised workshop.
- Rectify (or have rectified) the cause of the oil loss.
- Check the hydraulic oil level in the tank and correct if required.

1. Place the vehicle on a level surface and secure it with the parking brake. The dirt hopper must be lowered.
2. Switch the engine off and pull out the ignition key. Allow the engine to cool down.
3. Open the side flap **Fig. 158-B**, see page 183.
4. Check the hydraulic oil level at the sight glass. The hydraulic oil level should lie between the MIN and MAX mark.
5. If the hydraulic oil level is too low, top up hydraulic oil.

5.11.2 Topping up the hydraulic oil

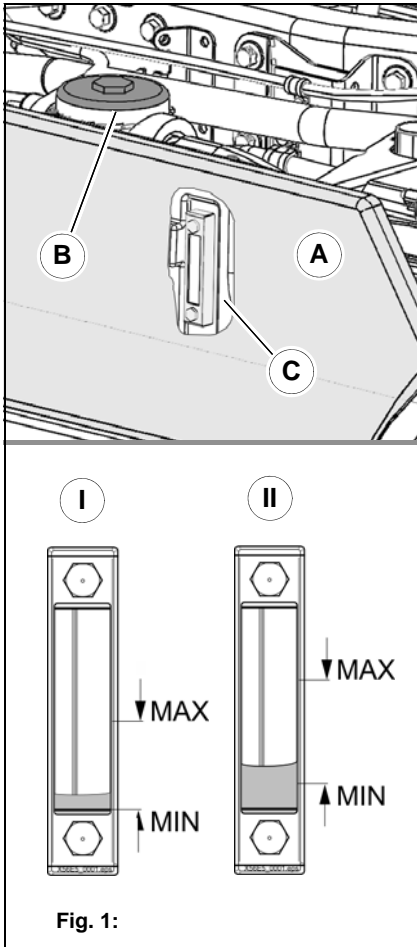

Fig. 1:

Observe the Safety instructions – Hydraulic system, see page 198.

1. Place the vehicle on a level surface and secure it with the parking brake.
 2. If necessary, raise the tipper.
 3. Switch the engine off and pull out the ignition key. Allow the engine to cool down.
 4. Open the side flap **Fig. 1-A**, see page 183.
 5. Unscrew the filler cap **Fig. 1-B** of the return filter and slowly top up hydraulic oil.
Hydraulic oil specification, see Engine/vehicle fluids and lubricants.
 6. Once all the hydraulic oil has returned into the hydraulic tank, check the hydraulic oil level at the sight glass **Fig. 1-C**.
 - Sketch **Fig. 1-I**: The hydraulic oil level is correct if it is visible at the lower edge of the sight glass.
 - Sketch **Fig. 1-II**: This ensures the level is between the MIN and MAX markings when the dirt hopper is lowered.
 7. Re-install the filler cap **Fig. 1-B** and lower the tipper again.
- Use only hydraulic oils approved by the manufacturer, see page 179.

5.11.3 Changing the return filter

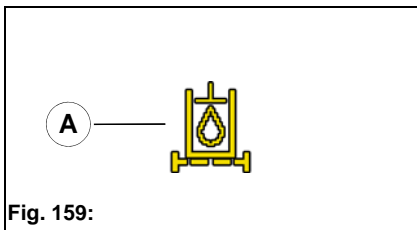

Fig. 159:

Observe the Safety instructions – Hydraulic system, see page 198.

If a return filter is soiled, it is signalled by the warning symbol **Fig. 159-A** in the multifunction display. Have the return filter replaced by an authorised workshop.

5.11.4 Hydraulic hose lines

Safety instructions – Hydraulic hose lines



Danger

- Take care when checking hydraulic lines, especially when searching for leaks. If hydraulic oil escapes under high pressure it can penetrate the skin and cause serious injuries. There is a risk of injury!
- Always consult a doctor immediately even if the wound seems insignificant, as otherwise serious infections could set in.
- Only retighten leaking screwed fittings and hose connections when the system is depressurised, i.e. release the pressure before working on pressurised lines.
- Never weld or solder faulty or leaking hydraulic hose lines or screw connections; replace damaged parts with new ones.
- Never search for leaks with your bare hands; wear protective gloves.
- Use paper or wood to check for minor leaks. Never use an unprotected light or naked flames.
- Make sure hydraulic hose lines are not twisted when they are being replaced.

Leaks and damaged hydraulic hose lines must be repaired or replaced as quickly as possible. This not only increases the operational safety of the vehicle, but also helps to protect the environment. Replace hydraulic hose lines **every five years** from the date of manufacture, even if they do not seem to be damaged.

For more information, please see:

- BGR 237 "Hydraulic Hose Lines", issued by the German Institution for Statutory Insurance in the Chemical Industry dated April 2008.
- ZH1/74 "Safety Rules for Hydraulic Hose Lines" in the relevant version, issued by the German Federation of Institutions for Statutory Accident Insurance and Prevention.
- DIN 20066 T5.

Identification of hydraulic hose lines

Regardless of the flexible line, each hydraulic hose line is permanently marked with at least the following information on the press sleeve:

- Manufacturer's name or identification, e.g. XXX
- Operating pressure (maximum working pressure) of hydraulic hose line, e.g. 330 bar
- The last two digits of the year of manufacture and the month of manufacture, e.g. 1610 for October 2016.

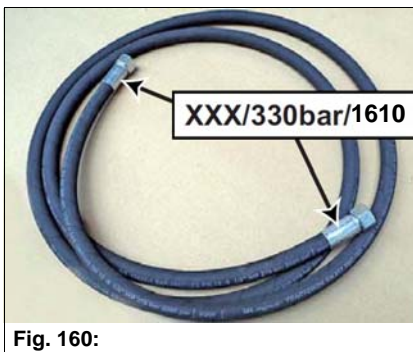



Fig. 160:

5.12 Gearbox

Safety instructions – Gearbox

	<p>Attention</p> <ul style="list-style-type: none">Depending on the respective function, the gearboxes of the Citymaster 2200 are filled with different oil grades. Therefore, do not try to correct the oil levels yourself as an incorrect oil can result in considerable damage. Always seek advice from an authorised workshop when detecting leaks. <p>Environmental danger</p> <ul style="list-style-type: none">Ensure safe and environment-conserving disposal of operating and auxiliary materials. Take up escaping or spilled operating materials in suitable containers and dispose of them in an environmentally friendly manner.
---	--

Checking the gearbox

Observe the Safety instructions – Gearbox, see page 202.
Maintenance of these components is limited to checking oil levels and changing the oil at the prescribed intervals. Maintenance intervals according to maintenance plan, see page 167.

	<p>Note</p> <p>The control, filling and draining screws at the individual gearboxes can best be accessed from below the vehicle. Only use new sealing rings for oil filler plugs and drain plugs. Only drain oil after running the vehicle for a long period of time.</p>
---	--

5.13 Brake system

Safety instructions – Brake system

**Danger**

- Repair work on the brake system must only be carried out by an authorised workshop. There is a risk of accidents!
- Caution when handling brake fluid. There is a risk of poisoning! Keep the brake fluid in the closed original container only, and keep out of the reach of children.
- Brakes are top-priority safety components; incorrect work can cause brake failure. All maintenance work performed on the brake system must be carried out by trained personnel. This does not include the following tasks, which must be performed by the operator of the vehicle:
 - Check the level in the brake fluid tank
 - Check the brake system daily for effectiveness, before starting to drive

Attention

- Contamination of the brake fluid can cause the brake system to fail! When working on the brake system, ensure that everything is extremely clean!
- Prevent brake fluid from coming into contact with the paintwork of the vehicle, as this may cause the paint to dissolve.
- Do not use mineral oil based brake fluid.
- Brake fluid specification, see Engine/vehicle fluids and lubricants.

Environmental danger

- Ensure safe and environment-conserving disposal of operating and auxiliary materials. Take up escaping or spilled operating materials in suitable containers and dispose of them in an environmentally friendly manner.

5.13.1 Checking the brake fluid

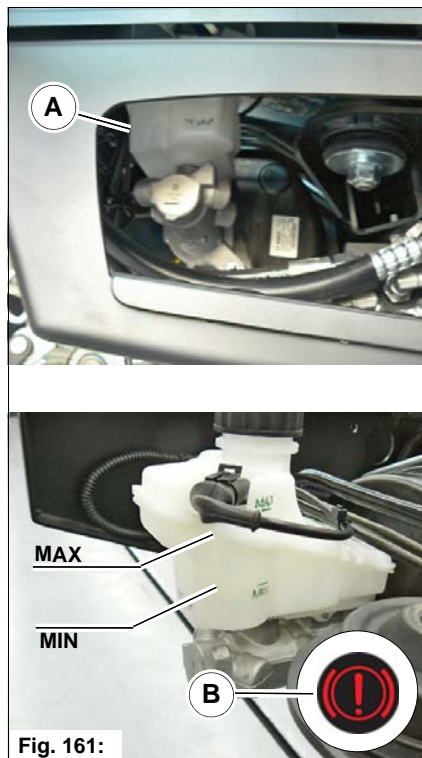

Fig. 161:

Observe the Safety instructions – Brake system, see page 203.

The brake fluid tank **Fig. 161-A** is located on the left-hand side underneath the vehicle cab. The filling level can be checked from the outside. An opening for topping up is located underneath the foot mat.

Check the brake fluid level at the brake fluid tank at regular intervals and top up as required. Maintenance intervals according to maintenance plan, see page 167. The warning symbol **Fig. 161-B** in the indicating device also lights up if the brake fluid level is too low.

1. Place the vehicle on a level surface and secure it with the parking brake.
2. Switch the engine off and pull out the ignition key. Allow the engine to cool down.
3. If the brake fluid level in the brake fluid tank is not between the MIN and MAX markings, top up brake fluid.

5.13.2 Topping up the brake fluid

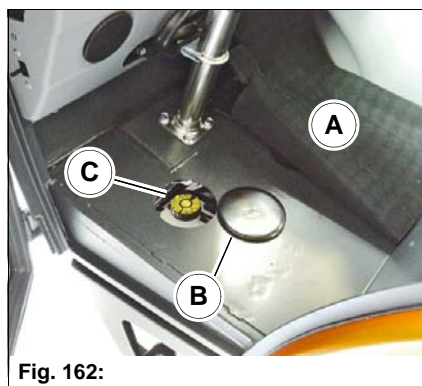

Fig. 162:

Observe the Safety instructions – Brake system, see page 203.

1. Put the foot mat **Fig. 162-A** aside and remove the blind cover **Fig. 162-B**.
2. Clean the filler cap **Fig. 162-C** and the area around the filler opening.



Attention

Contamination of the brake fluid can cause the brake system to fail! When working on the brake system, ensure that everything is extremely clean!

3. Remove the filler cap.
4. Top up original brake fluid up to the MAX marking.
5. Firmly screw the filler cap back on.
6. Make sure there is no leakage.

5.14 Air conditioning system

Safety instructions – Air conditioning system



Danger

- Caution when handling coolant – There is a risk of poisoning! Avoid any contact with the coolant. Have maintenance work on the air conditioning system done only by trained personnel.
- Do not open the refrigeration circuit.
- If splashed into the eyes, rinse immediately with fresh water and consult a doctor immediately.
- Do not perform welding on parts of the refrigeration circuit or in their immediate vicinity.
- Keep the coolant in the closed original container only, and keep out of the reach of children.

Attention

- Have the air conditioning system checked every two years, preferably in spring, by an authorised workshop. Maintenance intervals, see maintenance plan. Coolant specification, see Engine/ vehicle fluids and lubricants.

Environmental danger

- Ensure safe and environment-conserving disposal of operating and auxiliary materials. Take up escaping or spilled operating materials in suitable containers and dispose of them in an environmentally friendly manner.

5.14.1 Cleaning the condenser

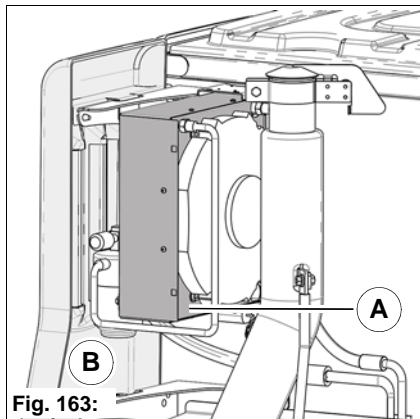

Observe the Safety instructions – Air conditioning system, see page 205. The condenser **Fig. 163-A** of the air conditioning system is located on the left-hand side of the vehicle behind the vehicle cab. Check the condenser for contamination at regular intervals. Maintenance intervals according to maintenance plan, see page 167.



Attention

If the condenser is clogged, the heat cannot be dissipated and the coolant will heat up and expand. This increases the pressure within the system. The system can burst, coolant can escape, which would stop the air conditioning system from being operational.

Clean the condenser as follows:

1. Place the vehicle on a level surface and secure it with the parking brake.
2. Switch the engine off and pull out the ignition key. Allow the engine to cool down.
3. Remove the left side cover **Fig. 163-B**, see page 183.
4. Blow out the condenser with compressed air towards the left-hand side of the vehicle.

5.14.2 Filling the air conditioning system

Observe the Safety instructions – Air conditioning system, see page 205. Due to the design, vehicle air conditioning systems cannot be hermetically sealed systems. Therefore, a (certain) creeping coolant loss is accepted by the automotive industry. It can thus be assumed that each vehicle air conditioning system becomes less efficient after a few years and must be refilled.

Have the air conditioning system filled by an authorised workshop. Maintenance intervals according to maintenance plan, see page 167. Coolant specification, see Engine/vehicle fluids and lubricants.

5.14.3 Cleaning the fresh air filter

Observe the Safety instructions – Air conditioning system, see page 205. Check the plate filter **Fig. 164-A** for contamination at regular intervals. Maintenance intervals according to maintenance plan, see page 167.

Remove the plate filter as follows:

1. Place the vehicle on a level surface and secure it with the parking brake. Switch the engine off and pull out the ignition key. Allow the engine to cool down.
2. Loosen the bolts of the plate filter housing **Fig. 164-B** and remove the plate filter housing.
3. Remove the plate filter and clean it if necessary.

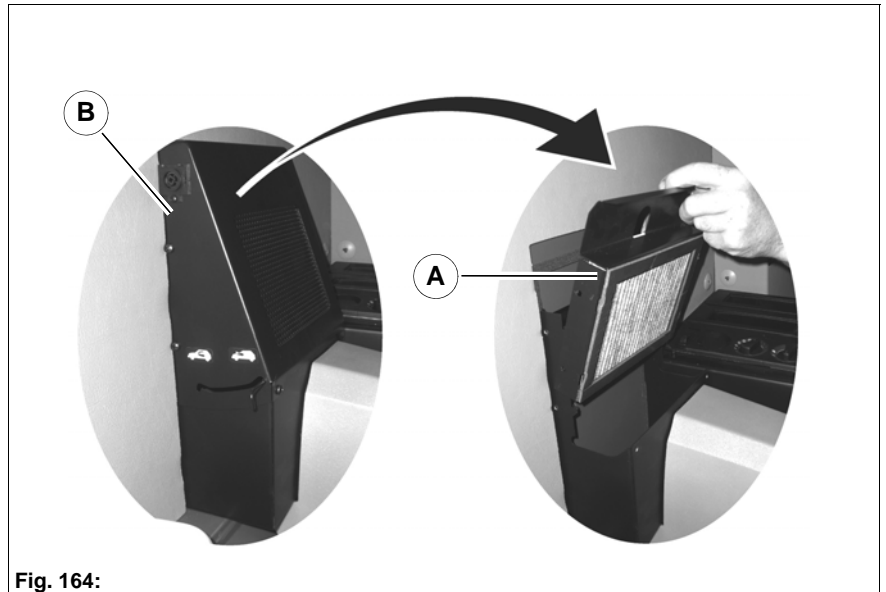



Fig. 164:

5.15 Wheels and tyres

Safety instructions – Wheels and tyres

	<p>Danger</p> <ul style="list-style-type: none"> • Repair work on wheels and tyres must only be carried out by an authorised workshop. There is a risk of accidents! • Damaged tyres and/or incorrect tyre pressure reduce the operating safety of the vehicle. There is a risk of accidents! • Due to the greater deformation with a lower tyre pressure, there is a risk of the vehicle tilting to the left and right. There is a risk of accidents! • New tyres do not have optimum adhesion and should therefore be run in for about 100 kilometres whilst driving carefully. There is a risk of accidents! • Worn tyres mean worse grip on the road, especially in wet conditions. Therefore, they should be replaced when the tread depth is down to 3 mm. Tyres older than 6 years must not be used. There is a risk of accidents! • Check the wheel bolts regularly to ensure that they are securely tightened. Check the wheel bolts 50 km after a tyre change, and tighten if necessary. There is a risk of accidents! <p>Attention</p> <ul style="list-style-type: none"> • Depending on the version, the wheel weighs between 30 and 48 kg. If necessary, ask a second person for help or use suitable lifting equipment. There is a risk of injury! • When changing wheels, make sure that the lifting equipment is applied to the specified jacking point. • Should the wheel size change, it must be reset by an authorised workshop in the vehicle. This is the only way to ensure that the drive control unit and ABS are functioning reliably and safely. • Only use tyres approved by Hako, see Technical data. <p>Environmental danger</p> <ul style="list-style-type: none"> • Ensure safe and environment-conserving disposal of old tyres.
---	---

5.15.1 Checking the tyres

Observe the Safety instructions – Wheels and tyres, see page 208. Check the tyres for wear at regular intervals. Maintenance intervals according to maintenance plan, see page 167.

- Check the tyre pressure and correct if necessary. Technical data, see page 160
- Check tyres and rims for damage (cracks, ageing etc.) – also on the inside.
- Remove foreign bodies from the tyre tread.
- Remove traces of oil and grease from the tyres.
- Check the wheel bolts to ensure that they are securely attached.
- Check the tyres for wear and measure the tread depth.
- If the tyre wear is very uneven: Have the track checked.

	<p>Note</p> <p>Regular inspection of tyres:</p> <ul style="list-style-type: none"> • Increases the operational safety and service life of the tyres and reduces vehicle downtimes.
---	--

5.15.2 Changing wheels

Removing the wheel

Observe the Safety instructions – Wheels and tyres, see page 208.

1. Place the vehicle on a level surface and secure it with the parking brake. Switch the engine off and pull out the ignition key.
2. Secure the vehicle by placing a wheel chock underneath the diagonally opposite wheel.
3. Remove the wheel bolt caps and loosen the wheel bolts (size 24) slightly.
4. Place the jack (hydraulic or mechanical version) underneath the jacking point.
5. Lift the vehicle until the wheel to be changed is off the ground.
6. Loosen the wheel bolts fully and remove the wheel from the axle.

The jacking points **Fig. 165-A** for jack or lifting platform at the carrier system:

- front left
- rear left
- front right
- rear right

Alternative jacking points of the jack underneath the axle tubes **Fig. 165-B**.



Attention

When lifting the entire vehicle using a lifting platform and the four jacking points **Fig. 165-A**, make sure the weight of the vehicle is distributed evenly. Otherwise, there is a risk of the vehicle tipping from the jacking points!



Fig. 165:

Assembling the wheel

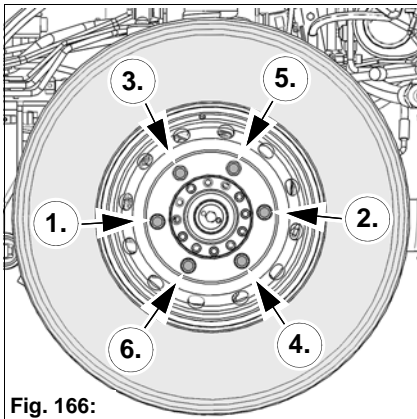

Fig. 166:

1. Place the wheel on the centring collar.
2. Screw on and tighten all wheel bolts slightly.
3. Lower the vehicle and remove the jack.
4. Tighten the wheel bolts to 380 Nm in the sequence shown.
5. Fit the wheel bolt caps.



Attention

Should the wheel size change, it must be reset by an authorised workshop in the vehicle. Only this way can it be ensured that the drive control unit and ABS are functioning reliably and safely.

6. After driving approx. 50 km, retighten the wheel bolts in the sequence shown and to the prescribed torque.

5.16 Windscreen washer unit

Safety instructions – Windscreen washer unit

	<p>Attention</p> <ul style="list-style-type: none"> If insufficient antifreeze has been added, the windscreen washer fluid can freeze and destroy the motor of the windscreen washer unit. Observe the correct mixing ratio when mixing the washer fluid with the additive or antifreeze. Refer to the manufacturer's instructions on the additive or antifreeze packaging. <p>Environmental danger</p> <ul style="list-style-type: none"> Ensure safe and environment-conserving disposal of operating and auxiliary materials. Take up escaping or spilled operating materials in suitable containers and dispose of them in an environmentally friendly manner.
---	--

5.16.1 Checking the windscreen washer unit

Observe the Safety instructions – Windscreen washer unit, see page 211. Check the windscreen washer unit at regular intervals. Maintenance intervals according to maintenance plan, see page 167.

- Check the condition of the wiper blades. When contaminated or damaged, they can considerably impair visibility.
- Remove grease, dirt and tar from the windscreen at regular intervals. This significantly increases the service life of the wiper blades.
- Check the windscreen washer unit nozzles to ensure that the water jet is correct. Use a needle to clear any nozzle blockages.
- Check the level of the windscreen washer unit, top up as required.

5.16.2 Topping up the windscreen washer unit

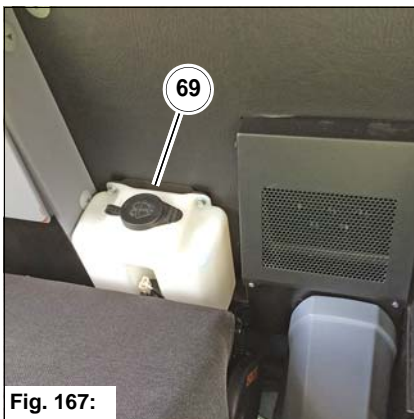



Fig. 167:

Observe the Safety instructions – Windscreen washer unit, see page 211. The windscreen washer fluid tank **Fig. 167-69** is located in the vehicle cab behind the driver's seat.

- Place the vehicle on a level surface and secure it with the parking brake. Switch the engine off and pull out the ignition key. Allow the engine to cool down.
- Fold down the backrest of the driver's seat.
- Open the windscreen washer fluid tank lid and top up the tank.

	<p>Note</p> <p>Fill with clean tap water only. Add a suitable windscreen detergent, if necessary, see Engine/vehicle fluids and lubricants.</p> <p>In winter: Mix the water with antifreeze for windscreen washer units. Refer to the usage instructions for the antifreeze for information on mixing ratios. If no windscreen detergent with antifreeze is available, methylated spirit may also be used. Never use coolant or other additives.</p>
---	---

5.17 Electrical system

Safety instructions – Electrical system



Danger

- Work on the electrical system may be done only in accordance with electrical engineering standards by a specialist trained for this work.
- Welding work on the vehicle may be done only by authorised Hako dealers. Welding work on the vehicle leads to damage to the control electronics and can impair driving safety.
- Danger of explosion due to smoking, fire or open light! Especially when being charged, but also in the normal use of batteries, batteries emit explosive gases! Avoid smoking, fire, sparks or open light in the vicinity of batteries!
- Danger of explosion due to sparks! Never place tools or other electrically conductive objects on the battery! Sparks that can ignite escaping gases arise if the poles are short-circuited.
- Danger of explosion due to frozen battery or too low acid level! With a frozen battery or if the acid level is too low, do not attempt to start with a jumper cable, the battery can burst or explode.
- Danger of burns due to battery acid! The special safety and accident prevention regulations must be complied with when handling the battery. Batteries contain sulphuric acid. Only store battery acid in the closed original container, and keep out of the reach of children.
- Risk of fire! When carrying out work on the fuses, switch off the electrical system to disconnect the consumers from the power supply. Use only original fuses. If stronger fuses are used, the electrical system can be destroyed and there can be fires.

Attention

- Always disconnect the battery when working on the electrical system or when performing welding work.
- Always observe the correct order when connecting and disconnecting the battery!
 - Disconnecting the battery: First the minus pole and then the plus pole!
 - Connecting the battery: First the plus pole and then the minus pole!
- After every maintenance task involving disconnecting the battery, make sure that the clamps are firmly seated on the terminals on re-connection.
- Disconnect the battery from the vehicle electrical circuits before recharging the battery. Do not disconnect the battery while the engine is running. Observe the precautions in the usage instructions and the product description for the battery. Do not use a battery charging device to start the engine.
- Note the operating voltage of the vehicle!
- Check the vehicle's electrical equipment at regular intervals. Defects such as loose connections or scorched cables must be removed immediately.
- Before replacing a light bulb, switch off the ignition to disconnect the consumers from the power supply. Only ever replace light bulbs with new ones with the same version and rating (amperage). Do not touch the glass bulb of the halogen light with your bare fingers.

Environmental danger

- Used batteries with the recycling symbol contain reusable commodities. In accordance with the symbol showing the crossed-out garbage bin, these batteries must not be disposed of in the domestic waste. Return and recycling have to be arranged with the authorised Hako dealer as required in § 6 and § 8 of the German battery law (BattG)!

5.17.1 Battery

Removing the battery

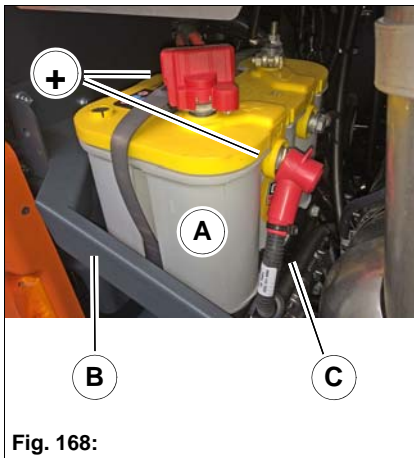

Fig. 168:

Observe the Safety instructions – Electrical system, see page 212.
The battery **Fig. 168-A** is located on the left behind the vehicle cab.



Note

The battery is "maintenance-free" and cannot be topped up.

To do this, proceed as follows:

1. Place the vehicle on a level surface and secure it with the parking brake. Switch the engine off and pull out the ignition key. Allow the engine to cool down.
2. Remove the left side cover, see page 183.
3. Remove the battery cover. If present, switch the battery switch off and remove the key.
4. Disconnect the connecting cable of the battery, **first both negative terminals (on the side and at the top), then both positive terminals (on the side and at the top)**.
5. Use a hexagonal socket wrench to loosen the two bolts of the holder for the side cover **Fig. 168-B**.
6. Loosen both bolts of the battery brace **Fig. 168-C** and remove the battery from the side.
7. Recharge the battery or replace it with a battery of the same type.
8. Clean the battery terminals and lubricate them with terminal grease.

Assembly is in reverse order. Observe the following:

1. When reconnecting the connecting cables, **connect both positive terminals (on the side and at the top) first, and then both negative terminals (on the side and at the top)**.
2. After every maintenance task involving disconnecting the battery, make sure that the clamps are firmly seated on the terminals on re-connection.



Environmental danger

Dispose of used batteries properly.

5.17.2 Fuses

The fuse rating is indicated by the mark **Fig. 169-A** and by the colour – see table below.

A defective fuse can be recognised by the melted metal strip **Fig. 169-B**.

The fuse box **Fig. 169-63** containing fuses F1 to F51 is located on the right rear panel of the vehicle cab. The fuse box **Fig. 169-64** containing fuses F52 to F67 is located on the left rear panel of the cab. The fuse box **Fig. 169-C** containing fuses F100 to F103 is located at the battery.

Observe the Safety instructions – Electrical system, see page 212.

Strength	Colour	Rating	Colour
1 A	Black	20 A	Yellow
3 A	Violet	25 A	Colourless
5 A	Beige	30 A	Green
7.5 A	Brown	40 A	Orange
10 A	Red	50 A	Red
15 A	Blue	80 A	Neutral

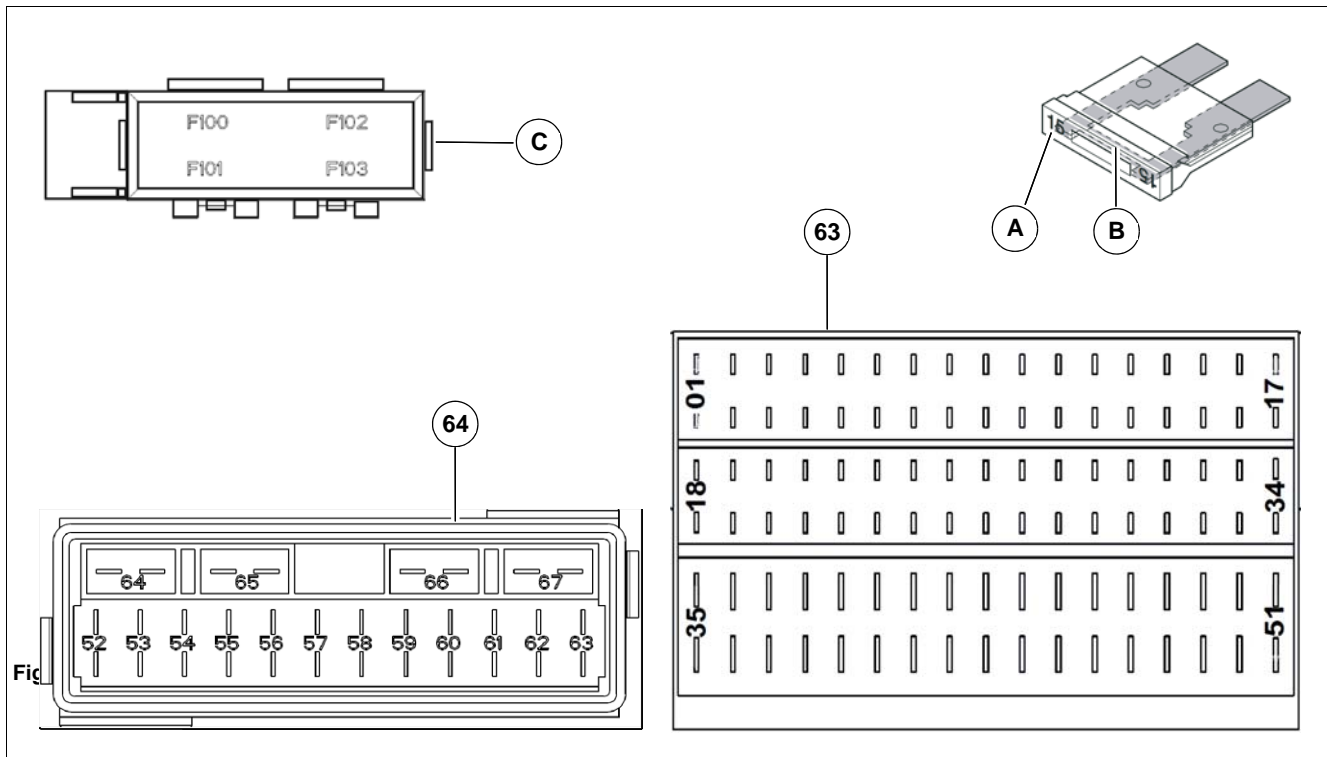

No.	Value (A)	Terminal	Consumer
F1	7.5 A	56	High beam, bottom left
F2	7.5 A	56	High beam, bottom right
F3	7.5 A	56	Low beam, bottom left
F4	7.5 A	56	Low beam, bottom right
F5	7.5 A	56	High beam, top left (option)
F6	7.5A	56	High beam, top right (option)
F7	7.5 A	56	Low beam, top left (option)
F8	7.5 A	56	Low beam, top right (option)
F9	5 A	56	Fog tail light
F10	7.5 A	58	Parking light / reversing light, left
F11	7.5 A	58	Parking light / reversing light, right
F12	5 A	58	Search light, working light relay
F13	3 A	15	Switch-on pulse / electronic unit of work hydraulics control unit
F14	5A	15	Switch-on pulse ABS control unit; engine control unit; brake light switch, EOBD socket
F15	5 A	15	Supply/Lighting for switches and tip switches; high beam relay; window heating tip switch; circulating water maintenance switch
F16	5 A	15	Reversing light, reversing camera (option)
F17	5A	15	AdBlue supply module; "attachment raised" sensor
F18	5 A	15	Radio (option); digital EU control device (option); wireless (option)
F19	3 A	15	Fleet-Recorder (option)
F20	10A	15	Turn indicator system
F21	5 A	15	Reversing valve for reversing fan operation (option)
F22	3 A	TFL	LED daytime running light
F23	15 A	X	Air-cushioned seat (option)
F24	15 A	X	Working spotlight
F25		X	Not used
F26	15 A	X	Windscreen washer unit; signal horn
F27	15 A	X	3-pin socket in the dashboard
F28	5 A	30	Radio (option); EU control device (option); wireless (option)
F29	3 A	30	Fleet-Recorder (option)
F30	20 A	30	Hazard warning flasher
F31	5 A	30	Beacon
F32	5 A	30	Rotating beacon, attachment (option)
F33	7.5 A	30	Interior lights
F34	3 A	30	Ignition lock; immobiliser; relay terminal 15
F35	5 A	30	Indicating device; EOBD socket; seat contact switch control unit

No.	Value (A)	Terminal	Consumer
F36		30	Not used
F37	1 A	30	Timer, independent vehicle heater (option)
F38	30 A	30	Windscreen heating (option); mirror heating (option)
F39	15 A	30	Central lubrication system (option)
F40	15 A	30	Cigarette lighter
F41	max. 20 A		Free usage
F42	1A	15	Switch-on pulse for control unit, hydrostatic control unit and indicating device
F43	15 A	15	Load, work hydraulics control unit
F44	15 A	15	Load, work hydraulics control unit
F45	15 A	15	Load, work hydraulics control unit
F46	max. 20 A		Free usage
F47	30 A	X	Circulating water switch-off; electrical interface to attachment, fresh water pumps
F48	15 A	X	13-pin socket
F49	7.5 A	X	Dirt hopper flap, pressure relief
F50	1 A	X	Terminal X signal for hydrostatic control unit
F51	7.5 A	X	Signal for tilting function, dirt hopper and dirt hopper flap
F52	5 A	30	Electronic unit of hydrostatic control unit
F53	20 A	30	ABS control unit power outputs
F54	20 A	30	NOx sensor relay
F55	20 A	30	Fuel filter heating
F56	20 A	30	Hydrostatic control unit power outputs
F57	10 A	30	Brake lights
F58	15 A	30	Heater fan when operating with independent vehicle heater
F59	20 A	30	Independent vehicle heater
F60	15 A	30	13-pin socket
F61	10A	HRM	Engine control unit power outputs
F62	15A	HRM	Engine control unit power outputs
F63	15 A	HRM	Relay for filter heating, glow plugs, NOx sensors, engine cabling, sensor "water in filter", Lamda sensor heating
F64	40 A	30	ABS control unit power outputs
F65	15 A	X	Heater fan
F66	15 A	D+	Electric fan at AC condenser
F67	15 A	D+	Seat heating
F100	60 A	30	Glow plugs
F102	15 A	D+	AdBlue supply module

Legend:

Terminal	Supply with
30	Steady plus battery
15	Switched on ignition
X	Switched on ignition, interrupted starting process
58	Light switch, stage 1 – parking light / reversing light
56	Light switch, stage 2 – headlights (high or low beam)
HRM	Ignition switched on via main engine relay
TFL	Switched on LED daytime running light
D+	Running diesel engine

5.17.3 Lamps

Observe the Safety instructions – Electrical system, see page 212.

We recommend always carrying spare light bulbs in the vehicle, as these are important for maintaining traffic safety.

Front headlights

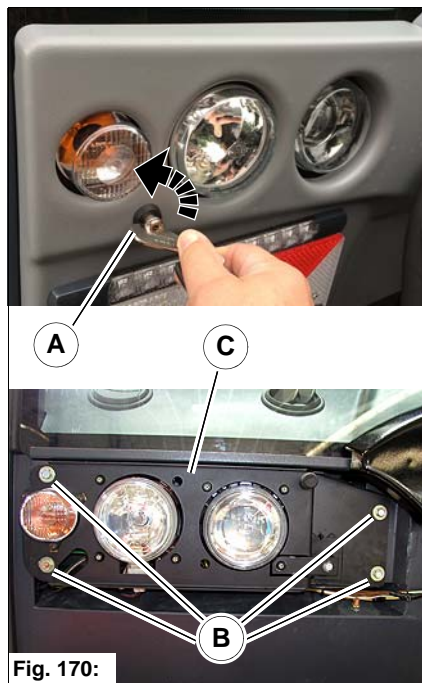

Fig. 170:

In order to change the light bulbs of the front headlights, open the front cover:

1. Use a special wrench from the toolbox to turn the lock **Fig. 170-A** on the left and right on the front cover by 90° to the vertical position.
2. Fold the front cover forwards.
3. Remove the hexagon nuts **Fig. 170-B**.
4. Tilt the headlight plate **Fig. 170-C** to the rear.

High beam headlights

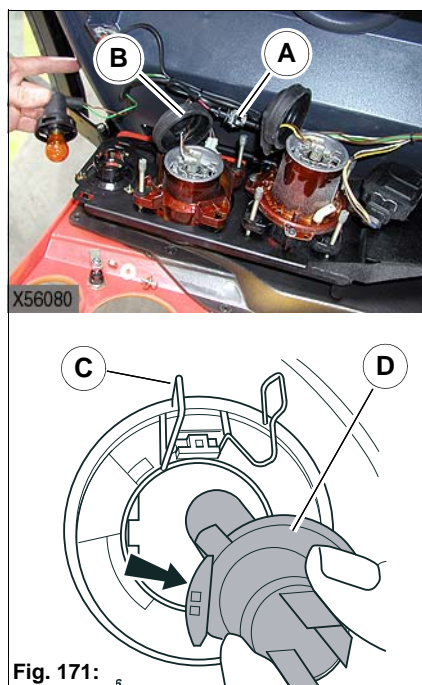

Fig. 171:

Changing the light bulb in the front high beam headlight:

1. Remove the cable plug **Fig. 171-A**.
2. Remove the sealing cap **Fig. 171-B**.
3. Squeeze the tension spring **Fig. 171-C** together with your fingers and remove the light bulb **Fig. 171-D**.
4. Hold the new light bulb **Fig. 171-D** at the lamp socket, do not touch the glass bulb, and insert it in the headlight.
5. Pay attention to the locking device that ensures correct positioning of the light bulb **Fig. 171-D** in the headlight (see figure).
6. Install the tension spring **Fig. 171-C**, the sealing cap **Fig. 171-B** and the cable plug **Fig. 171-A** in reverse order.

Parking light

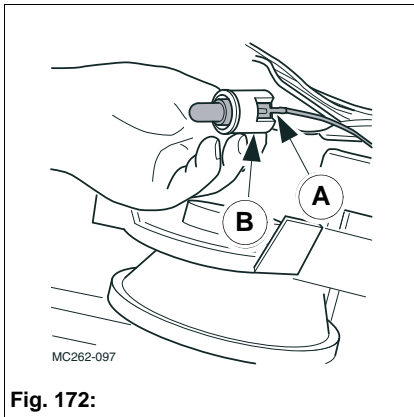
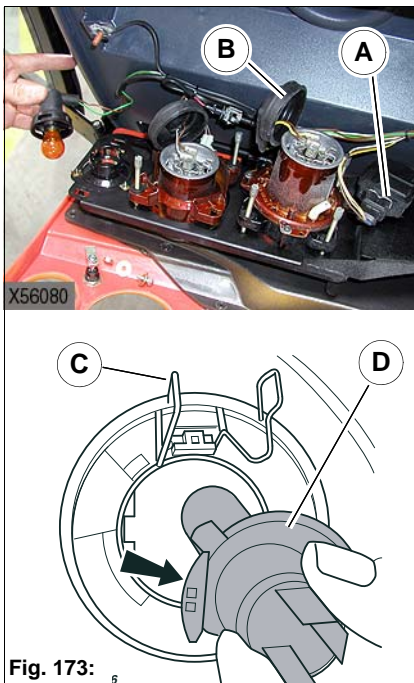

Fig. 172:

Changing the light bulb of the parking light:

1. Remove the cable plug **Fig. 172-A**.
2. Loosen the lamp socket **Fig. 172-A** by turning it and remove it from the reflector.
3. Replace the light bulb.
4. Install in reverse order.

Low beam headlights



Changing the light bulb in the low beam headlight

1. Remove the cable plug **Fig. 173-A**.
2. Remove the sealing cap **Fig. 173-B**.
3. Squeeze the tension spring **Fig. 173-C** together with your fingers and remove the light bulb **Fig. 173-D**.
4. Hold the new light bulb **Fig. 173-D** at the lamp socket, do not touch the glass bulb, and insert it in the headlight.
5. Pay attention to the latch, that ensures correct positioning of the light bulb **Fig. 173-D** in the headlight (see figure).
6. Install the tension spring **Fig. 173-C**, the sealing cap **Fig. 173-B** and the cable plug **Fig. 173-A** in reverse order.

Turn indicators

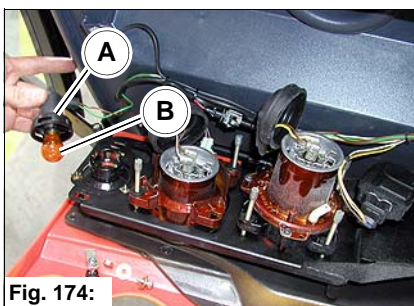

Changing the light bulbs of the front turn indicators

1. Rotate the lamp housing **Fig. 174-A** to the left using light pressure.
2. Slightly press down the light bulb **Fig. 174-B**, rotate half a turn and remove.
3. Press in the new light bulb **Fig. 174-B** and rotate half a turn.
4. Insert the lamp housing **Fig. 174-A** and rotate it to the right using light pressure.

Side turn indicators

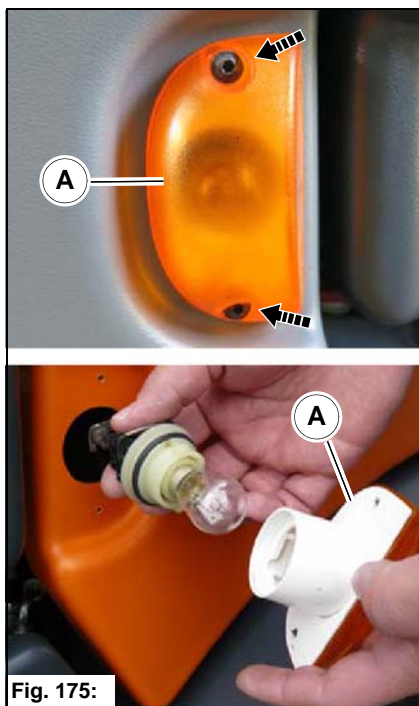

Fig. 175:

Changing the light bulbs of the side turn indicators:



Note

The turn indicator does not have to be removed for changing the light bulb. For better illustration, the turn indicator has been removed in the figures.

1. Use a size 15 Torx key to loosen the bolts of the turn indicator **Fig. 175-A**.
2. Turn light bulb socket 90° in an anti-clockwise direction whilst holding on to the turn indicator.
3. Remove light bulb socket from the turn indicator.
4. Slightly press down the light bulb, rotate half a turn to the left and remove.
5. Press in new light bulb and rotate half a turn.
6. Insert light bulb socket into the turn indicator.
7. Turn the light bulb socket 90° in a clockwise direction whilst holding on to the turn indicator.
8. Screw on the turn indicator using Torx bolts.

Interior light

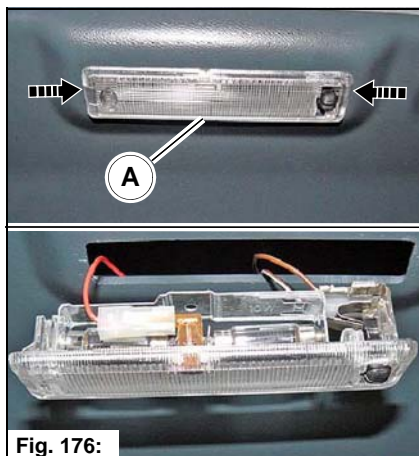

Fig. 176:

Changing the light bulb of the interior light:

1. Use a screwdriver to carefully lever the interior light **Fig. 176-A** out of the roof panelling.
2. Replace the light bulb and re-insert the interior light.

Rear lights

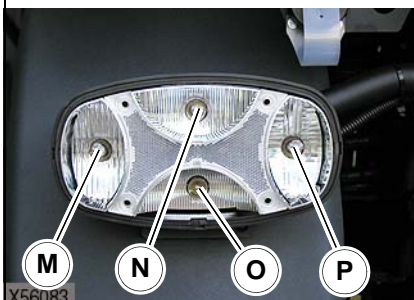
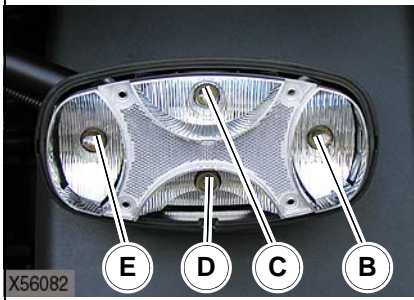

Fig. 177:

Auxiliary headlights (option) and working lights

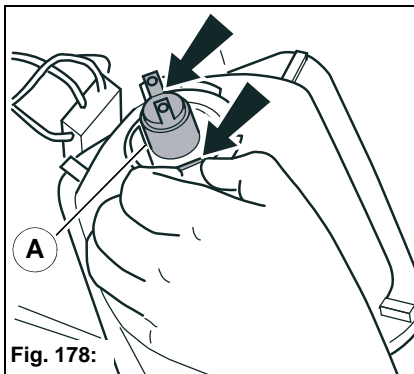

Fig. 178:

Changing the light bulbs of the rear lights:

Loosen the screws **Fig. 177-A** and remove the light cover.



Note

- The reversing light **Fig. 177-E** is the rear fog light with left-hand-traffic models (UK).
- The rear fog light **Fig. 177-P** is the reversing light with left-hand-traffic models (UK).

The right-hand rear light contains the light bulbs for:

- Turn indicators **Fig. 177-B**
- Brake light **Fig. 177-C**
- Taillight **Fig. 177-D**
- Reversing light **Fig. 177-E**

The left-hand rear light contains the light bulbs for:

- Turn indicators **Fig. 177-M**
- Brake light **Fig. 177-N**
- Rear lights and numberplate light **Fig. 177-O**
- Rear fog light **Fig. 177-P**

Slightly press down the respective light bulb, rotate half a turn and remove. Press in the new light bulb and rotate half a turn. Attach the light cover and attach with the screws **Fig. 177-A**.

Changing the light bulbs of the auxiliary headlights and working lights:

1. Remove the headlight cover.
2. Unscrew the lamp cover or the lamp reflector.
3. Press the tension spring **Fig. 178-A** down and to the side (see figure), hold the lamp by the socket and pull it out.
4. On the auxiliary headlight, remove the lamp cable and connect the new lamp with cable.
5. Refasten the tension spring and then install the lamp again.

5.18 Vacuum sweeping system

Safety instructions – Vacuum sweeping system



Danger

- It is not permitted to stand underneath the dirt hopper if it is not secured. Always fit the safety strut whenever working underneath the dirt hopper. There is a danger to life!
- Special caution is required in the area of the front and rear-mounted equipment and attachments. There is a danger to life!

5.18.1 Safety strut

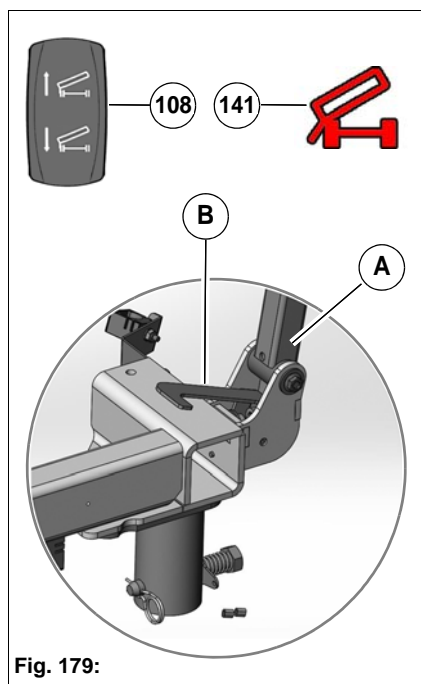

Fig. 179:

Observe the Safety instructions – Vacuum sweeping system, see page 222.

The dirt hopper must be raised and secured for maintenance work underneath the dirt hopper (engine, hydraulic system, air conditioning system, cooling system, fan, battery, etc.).

Raise and secure the dirt hopper:

1. Raise the dirt hopper with the tip switch **Fig. 179-108** above the safety strut.
2. Lower the dirt hopper with the tip switch **Fig. 179-108** until the safety strut **Fig. 179-A** engages.
3. Check the locking position of the safety strut.

After completing the maintenance work, move the dirt hopper back to the lower end position:

1. Lower the dirt hopper with the tip switch **Fig. 179-108** until the safety strut is free.
2. Unlock the safety strut with the lever **Fig. 179-B**.
3. Lower the dirt hopper again with the tip switch **Fig. 179-108** until it has reached the lower end position.



Note

- As long as the dirt hopper is not in its lower end position, the warning symbol **Fig. 179-141** appears in the indicating device and the buzzer sounds once.
- Once the end position has been reached, the lever is in its locking position again.

5.18.2 Presetting 3rd brush

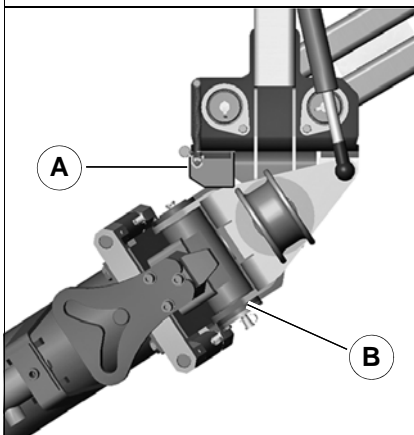
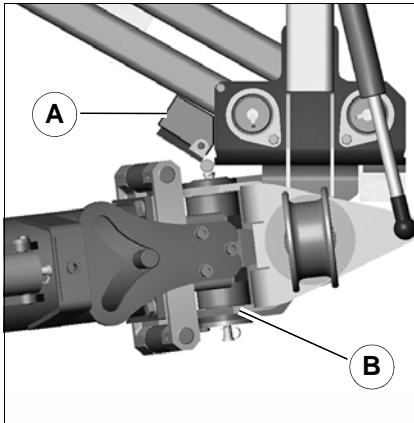

Fig. 180:

Observe the Safety instructions – Vacuum sweeping system, see page 222.

Using the buffer **Fig. 180-A**, the 3rd brush can be set in two positions.

- 0° position for working close to the vehicle or transport journeys (This position is only possible if the brush arm **Fig. 180-B** is on the right-hand side in driving direction)
- 45° position for working in a symmetrical manner (This position is possible on both sides)

Proceed as follows to change from 0° position to 45° position:

1. Lower the 3rd brush with the joystick.
2. Swivel out the brush arm **Fig. 180-B** manually.
3. Position the buffer **Fig. 180-A** as shown in the figure below.

5.18.3 Checking the sweeping level (2-brush system)

Observe the Safety instructions – Vacuum sweeping system, see page 222.

Check the sweeping level **Fig. 181-A and B** for the brushes at regular intervals. Maintenance intervals according to maintenance plan, see page 167.

The sweeping level **Fig. 181-A and B** is adjusted in the factory with the screws **Fig. 181-C and D**.

1. Raise the sweeping unit with the joysticks **Fig. 181-113 and 114**.
2. Drive over a level surface covered with dust or chalk.
3. Lower the sweeping unit and let the brushes turn for a short time.
4. With correctly adjusted sweeping level, the following pattern must result in driving direction:
 - The left rotating brush **Fig. 181-A** from 8 a.m. to 2 p.m.
 - The right rotating brush **Fig. 181-B** from 10 a.m. to 4 p.m.

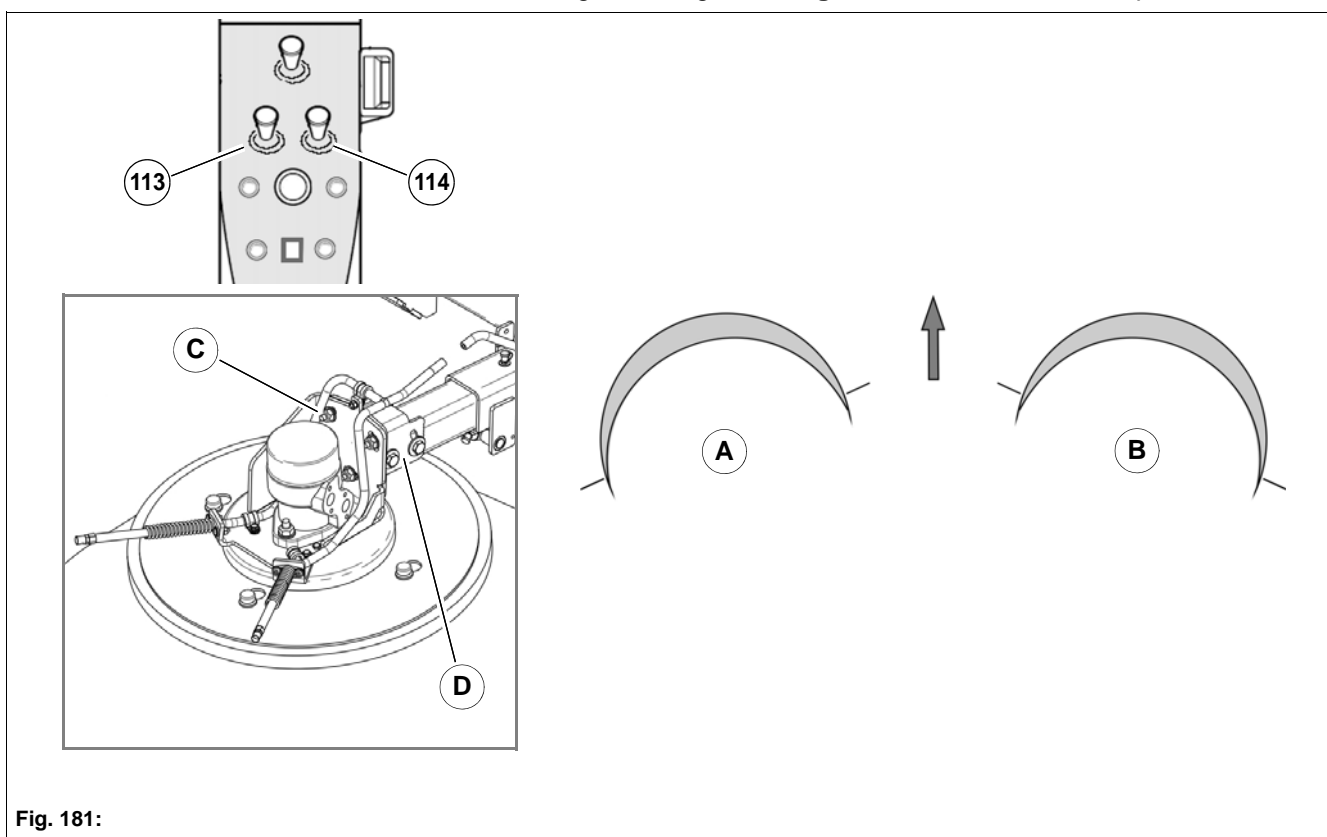

Fig. 181:

5.18.4 Checking the sweeping level (3-brush system)

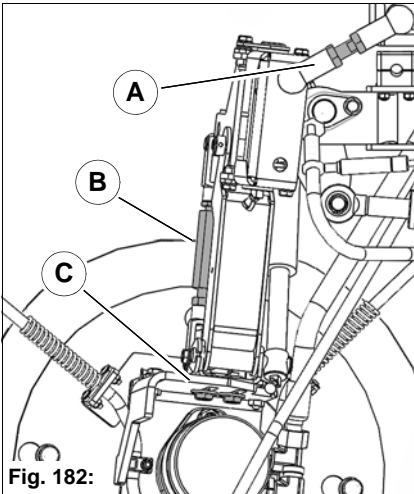

Fig. 182:

Observe the Safety instructions – Vacuum sweeping system, see page 222.

Check the sweeping level **Fig. 183-A and B** for the pulled brushes at regular intervals. Maintenance intervals according to maintenance plan, see page 167.

The sweeping level **Fig. 183-A and B** for the pulled brushes is adjusted in the factory with the screws **Fig. 182-A, B and C**.

The sweeping level **Fig. 183-C** for the 3rd brush is adjusted in the factory with the four screws **Fig. 183-D**.

1. Raise the sweeping unit with the joysticks **Fig. 183-113 and 114**.
2. Drive over a level surface covered with dust or chalk.
3. Lower the sweeping unit and let the brushes turn for a short time.
4. With correctly adjusted sweeping level, the following pattern must result in driving direction:

- Pulled brushes:
 - The left rotating brush **Fig. 183-A** from 10 a.m. to 4 p.m.
 - The right rotating brush **Fig. 183-B** from 8 a.m. to 2 p.m.
- 3rd brush **Fig. 183-C**:
 - from 10 a.m. to 4 p.m.

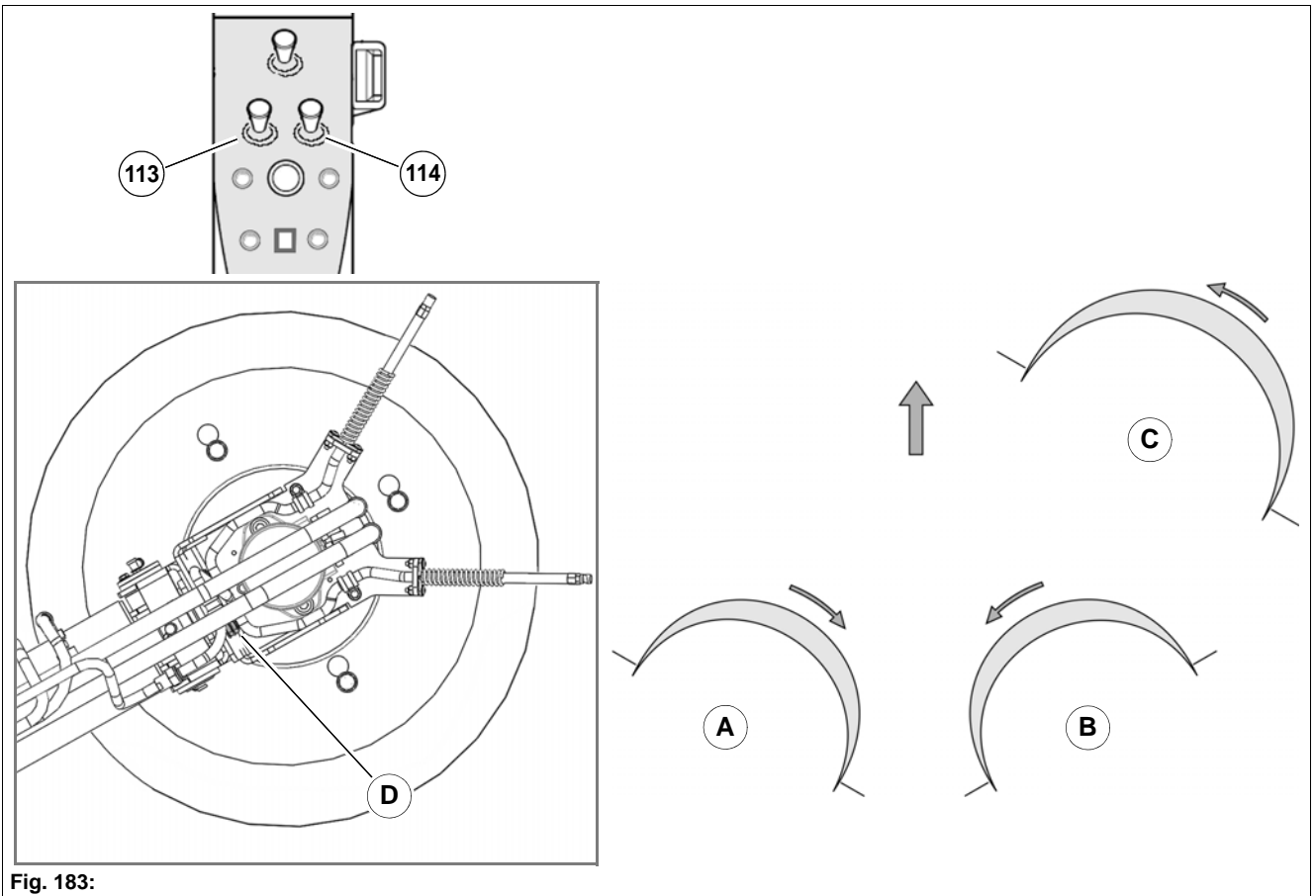

Fig. 183:

5.18.5 Checking the suction mouth sealing strips (2-brush system)

Observe the Safety instructions – Vacuum sweeping system, see page 222.

Check the sealing strips **Fig. 184-A** of the suction mouth at regular intervals. Maintenance intervals according to maintenance plan, see page 167.

Immediately replace defective seals, also on the coarse material flap **Fig. 184-B**, since the suction power is reduced.

The sealing strips must have a ground clearance of 8.5 ± 2 mm and 10 ± 2 mm at the front and at the rear respectively. The coarse material flap is set to a ground clearance of 20 ± 5 mm. Loosen the wheel holders **Fig. 184-C** in order to set the sealing strips.



Note

PU sealing strips (option) must have a ground clearance of 8.5 ± 2 mm and 10 ± 2 mm at the front and at the rear respectively.

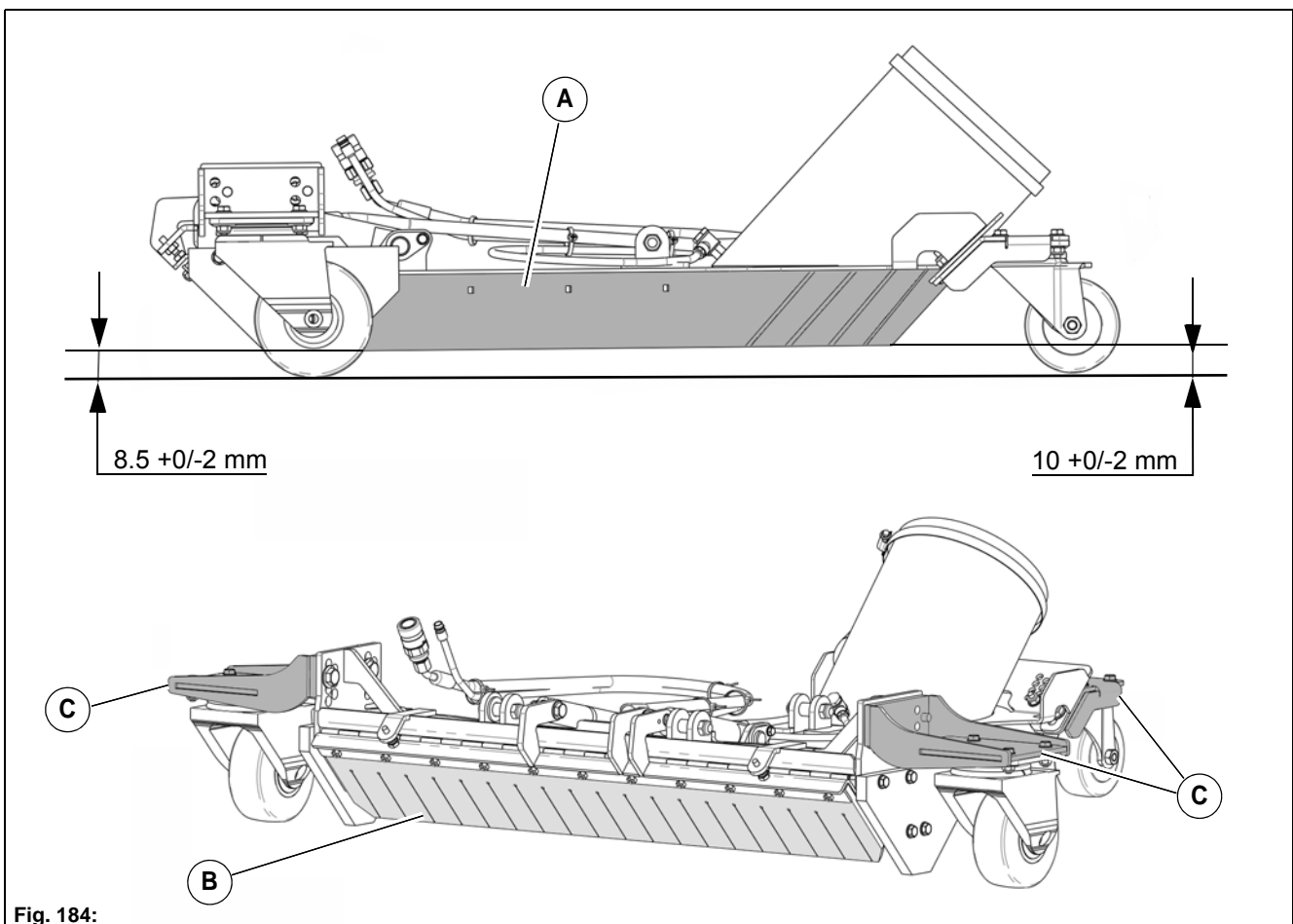

Fig. 184:

5.18.6 Checking the suction mouth sealing strips (3-brush system)

Observe the Safety instructions – Vacuum sweeping system, see page 222. Check the sealing strips **Fig. 184-A** of the suction mouth at regular intervals. Maintenance intervals according to maintenance plan, see page 167.

Immediately replace defective seals, also on the coarse material flap **Fig. 184-B**, since the suction power is reduced.

The sealing strips must have a ground clearance of 5 ± 2 mm and 15 ± 2 mm at the front and at the rear respectively. The coarse material flap is set to a ground clearance of 20 ± 2 mm.

Loosen the wheel holders **Fig. 184-C** in order to set the sealing strips.



Note

PU sealing strips (option) must have a ground clearance of 3 ± 2 mm and 7 ± 2 mm at the front and at the rear respectively.

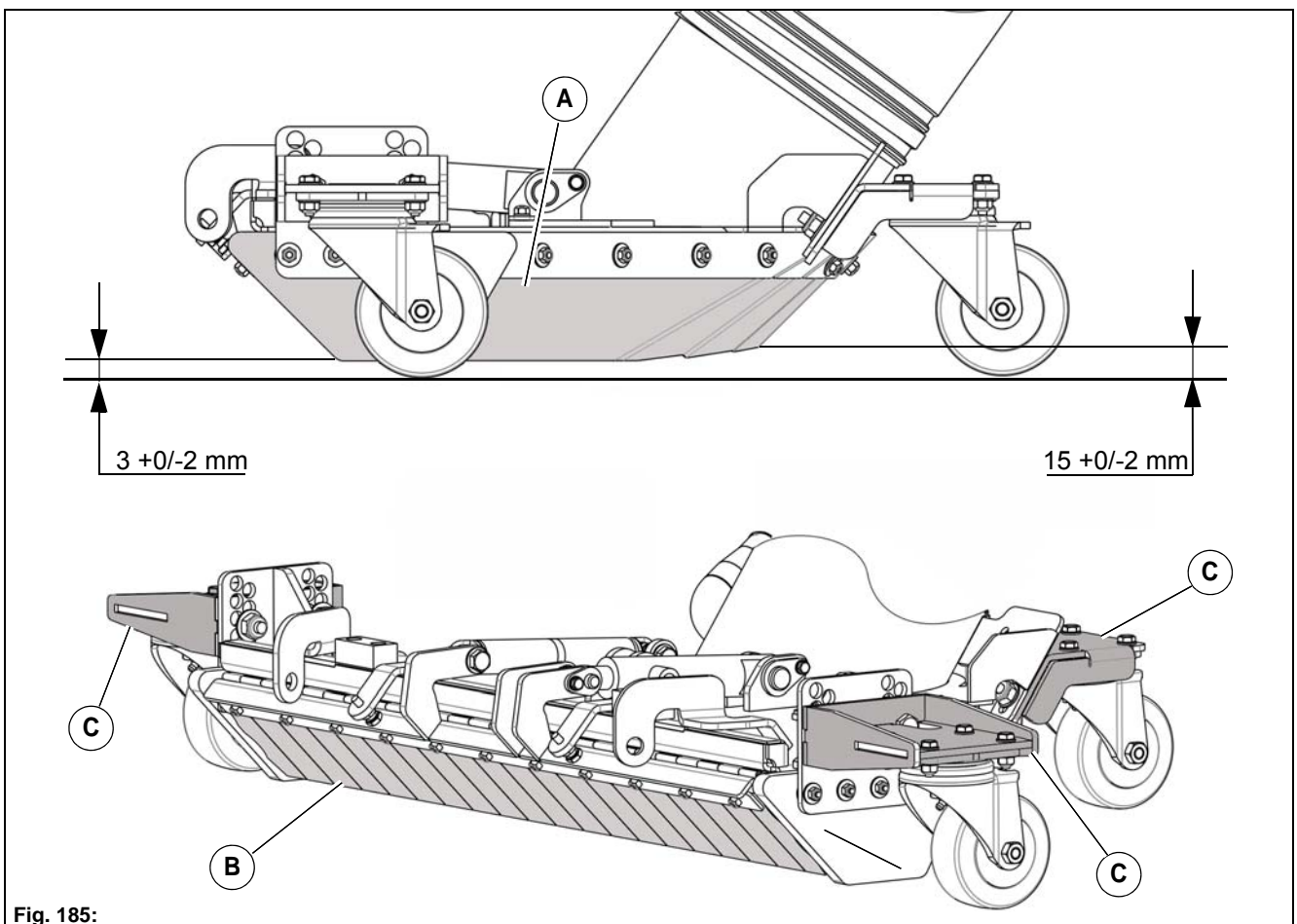

Fig. 185:

5.18.7 Seal at the suction duct

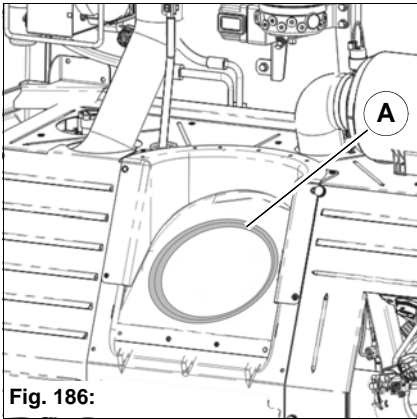

Fig. 186:

Observe the Safety instructions – Vacuum sweeping system, see page 222.

Check the suction duct seal **Fig. 186-A** at regular intervals. Maintenance intervals according to maintenance plan, see page 167. Immediately replace a defective suction duct seal.

5.18.8 Seal at the dirt hopper

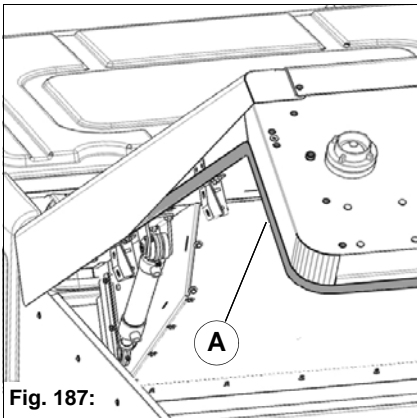

Fig. 187:

Observe the Safety instructions – Vacuum sweeping system, see page 222.

Check the dirt hopper seal **Fig. 187-A** at regular intervals. Maintenance intervals according to maintenance plan, see page 167. Immediately replace a defective dirt hopper seal.

5.19 General service and maintenance work

5.19.1 Vehicle cleaning

A distinction is made between 3 areas in vehicle cleaning:

- Vehicle cab, inside
- Complete vehicle outside
- Engine space

Here the wrong choice of cleaning equipment and agents can impair the operating safety of the vehicle and also endanger the health of the cleaning personnel. Therefore the following instructions should be followed without fail:



Environmental danger

Use only dedicated washing places for cleaning the vehicle.

General instructions for all the areas of the vehicle

When using washing solutions

- Ensure sufficient room ventilation!
- Wear suitable protective clothing
- Do not use any combustible liquids such as petrol or diesel fuel

When using compressed air

- Work carefully
- Wear eye protection and protective clothing
- Do not direct compressed air onto the skin or towards other persons
- Do not use compressed air for cleaning clothes

When using a high-pressure cleaner or steam jet cleaner

- Maintain a minimum distance of at least 30 cm!
- Max. pressure 120 bar at max. 80 °C
- Cover electrical parts and insulating mats and do not expose them to a direct jet.
- Cover these parts and do not expose them to a direct jet: vent grilles on the rear wall of the vehicle cab, venting filter of the hydraulic oil tank, lid of the fuel and hydraulic oil tank, etc.
- Protect the following components against moisture:
 - Electrical parts, such as three-phase generator, sensors, electrical plug connections, engine control unit, etc.
 - Control devices and seals
 - Air suction filter etc.

When using volatile and easily flammable anti-rust agents and sprays:

- Ensure sufficient room ventilation!
- Use no naked fire or light!
- Do not smoke!

Care of the outside body

Wash your vehicle at regular intervals with water and a mild detergent. How frequently the vehicle has to be washed depends on the following factors:

- Area of use of the vehicle
- Driving on roads spread with salt
- Parking under trees with resinous excretions

Observe the following when washing:

- Do not use any coarse brushes or dirty cloths to prevent scratching and dulling the paintwork
- Do not wash the vehicle if it has been exposed to sunshine for a long time, the paintwork could lose its gloss by this

Cleaning plastic parts

Clean outer plastic parts like the vehicle. If dirt cannot be removed in this way, we recommend special plastic cleaners. You can also use these inside the vehicle for plastic parts.

Do not use any paint cleaners or products containing solvents, methanol or hydrocarbons.

Cleaning glass areas

Use special glass cleaners and clean cloths to avoid scratches and dulling.

Vehicle cab, inside



Attention

Never use high-pressure cleaners, steam jets or high-pressure water jets to clean the inside of the vehicle cab. Water under high pressure may:

- Penetrate the vehicle electrical system and cause a short circuit,
- Damage seals and make operating elements defective!

We recommend the following aids for cleaning the vehicle cab:

- Vacuum cleaner
- Damp cloths
- Soft brush
- Bucket of water

Cleaning fabric surfaces

Remove dust on seats and other fabric surfaces with a soft brush or vacuum cleaner. More thorough cleaning can be achieved with special upholstery detergents. Observe the directions for use and danger notes of the manufacturer!

Solvents on a chlorine basis may not be used.

Engine compartment



Danger

Clean the engine at engine standstill only – otherwise there is a risk of injury! Switch the engine off before cleaning.



Attention

When cleaning the engine with a water or steam jet cleaner, do not expose electrical plug connections and sensors, such as oil pressure switch, to a direct jet.
Otherwise penetrating moisture can lead to corrosion and to failure of the measuring function!

5.19.2 Special tightening torques

Designation	Tightening torque
Wheel bolts	380 Nm
Oil drain screw, engine oil sump	30 Nm
Engine oil filter (oiled seal)	25 Nm
Pressure filter, drive	45 Nm

5.19.3 Screw connections

Screw connections on supporting parts subjected to heavy loads (e.g. axles, engine, chassis, trailer coupling etc.) should be checked at regular intervals, especially if they have been loosened for maintenance and repair work.

Tighten any loose screw connections immediately.

5.20 Troubleshooting

5.20.1 Troubleshooting at the vehicle

Malfunction/fault	Possible cause	Actions/rectification
Diesel engine		
Diesel engine does not start	• Fuel tank empty	• Refuelling • Have fuel system bled
	• Fuel system contaminated • Fuel filter contaminated	• Have fuel filter maintained • Have fuel system cleaned
	• Fuel system draws air, leaks	• Have fuel system checked for leaks
	• Low outdoor temperatures	• Preheat
	• Starter has inadequate power	• Check cable connections • Recharge the battery
	• Battery has no voltage	• Recharge the battery
Diesel engine difficult to start or stops again immediately	• Fuel system contaminated • Fuel filter/pre-filter contaminated	• Have fuel system cleaned • Carry out fuel filter maintenance
	• Air in fuel system	• Bleed fuel system
	• Fuel lines pinched or damaged	• Have repaired
	• Excessive injector return flow	• Have repaired
	• Pressure on a work hydraulics pump	• A main or secondary consumer function has been deactivated due to a fault • e.g. slider is jammed • Investigate and eliminate the fault
Starter does not have adequate power on start-up	• Battery pole terminals loose or oxidised	• Clean pole terminals and connect them correctly
	• Starter cable loose or broken	• Tighten cable or replace cable lug
	• Starter defective	• Have repaired
Diesel engine with inadequate power	• Fuel system contaminated • Fuel filter contaminated	• Carry out fuel filter maintenance • Clean fuel tank
	• High-pressure pump defective	• Have repaired
	• Air filter soiled	• Clean filter insert
	• Engine temperature too high – engine control switches to emergency operation	• Check coolant level, top up coolant • Cleaning the radiator fins
	• Unsuitable fuel	• Fuel specification
	• Error entry in engine control unit – engine control unit switches to emergency operation	• Have error memory read by authorised workshop • Switch motor and ignition off, re-start
Diesel engine emits blue-black smoke	• Diesel engine has high oil consumption	• Switch off diesel engine, have repaired
Diesel engine runs loudly	• Exhaust system leaks or is loose	• Have exhaust system checked
Diesel engine makes noises	• Diesel engine has internal damage	• Switch off diesel engine, have repaired

Malfunction/fault	Possible cause	Actions/rectification
Diesel engine knocks	• Wrong fuel in tank	• Have fuel in fuel system replaced • Have fuel system bled
	• Damage to diesel engine	• Have repaired
	• Damage to injection system	• Have repaired
Diesel engine does not have sufficient oil pressure	• Oil level too low	• Check oil level, top up engine oil
	• Diesel engine leaks, loses oil	• Check for leaks, have it sealed if required
Oil level in diesel engine increases	• Cylinder-head gasket leaks	• Have repaired
Diesel engine jerks when starting and switching off	• Engine suspension loose or worn	• Have engine suspension tightened • Have repaired
Engine oil in cooling system	• Internal leaks	• Switch off engine, have repaired
Cooling system		
Diesel engine gets too hot (run engine for a short time at idle speed and switch off)	• Not enough coolant in cooling system	• Check the coolant level • Have cooling system checked for leaks
	• Radiator fins contaminated	• Cleaning the radiator fins
	• Cooling system contaminated	• Have the inside of the cooling system cleaned and degreased
Engine oil in cooling system	• Internal leaks	• Switch off engine, have repaired
Electrical system		
Diesel engine does not start	• Operating error	• Drive lever in neutral position and accelerator pedal not pressed
	• Battery empty or not charged sufficiently	• Recharge the battery
	• Drive lever contact switch defective	• Have repaired
Battery empty or not charged sufficiently	• Cable break between alternator and battery	• Switch off engine immediately, have repaired
Charging telltale does not light up when engine is switched off	• Regulator defective, light bulb defective	• Have repaired
	• Battery discharged	• Recharge the battery
Charging telltale does not go out at higher engine speed	• V-belts of alternator loose or torn	• Have V-ribbed belts of alternator repaired
Windscreen washer unit does not work	• Fuse defective	• Replace fuse
	• Suction line contaminated or broken	• Clean line or have it replaced
	• Hose lines/vent frozen	• Antifreeze for windscreen washer unit
	• Windscreen washer unit tank empty	• Check windscreen washer unit

Malfunction/fault	Possible cause	Actions/rectification
Headlight effect inadequate	• Mirror insert and spreader disc matt	• Vehicle not in safe condition, have repaired
	• Light bulb inefficient	• Clean or change light bulb
	• Headlight contaminated	• Clean headlight
	• Poor contact at supply line or ground connection	• Clean contacts
	• Incorrect adjustment	• Have adjustment checked and readjusted
Gearbox, drive shafts		
Noise from drive elements	• Cardan shafts loose, worn	• Have cardan shafts lubricated and cardan shaft flanges repaired
Drive axles		
Cracking noises when cornering	• Drive shaft worn	• Vehicle not safe to operate, have repaired
	• Wheel bolts loose	• Check firm seating of wheel bolts and tighten with a torque spanner
Brake system		
Uneven braking effect	• Tyres worn unevenly	• Tyre change
	• Uneven tyre pressure	• Check and correct tyre pressure
	• Oil on brake linings	• Vehicle not safe to operate, have repaired
	• Brake linings worn unevenly	
No or insufficient braking effect	• No brake fluid in expansion tank	• Top up brake fluid and determine cause of brake fluid loss • Vehicle not safe to operate, have repaired
	• Brake system leaks	• Vehicle not safe to operate, have repaired
	• Vacuum pump defective	
	• Oil or heavy contamination on brake linings	
	• Brake linings worn	
	• Power brakes defective	
Parking brake does not release	• Brake cable stuck	• Vehicle not safe to operate, have repaired
Chassis		
Vehicle is unsteady and wobbles when driving	• Wheel imbalance or damaged wheels	• Tyre change • Changing wheels
Vehicle is hard to steer, pulls to one side or floats when cornering	• Incorrect tyre pressure	• Check and correct tyre pressure
	• Incorrect wheel alignment	• Have repaired
	• Flat tyre	• Changing wheels
	• Steering worn	• Vehicle not safe to operate, have repaired

5.20.2 Troubleshooting at the vacuum sweeping system

Malfunction/fault	Possible cause	Actions/rectification
The fresh water supply is interrupted	• The fresh water tank is empty	• Top up the fresh water tank
	• The fresh water system is clogged	• Clean the sieve filter and reducing piece • Clean the spray nozzles and ball valve filters
The circulating water supply is interrupted	• The circulating water system is empty	• Fill the dirt hopper up to the mark
	• The circulating water system is clogged	• Flush the circulating water system with water • Clean the circulation water system and lock the sump valve
	• Sump valve was unlocked when emptying the dirt hopper	
The sweeping power is reduced	• The coarse material flap is still open	• Close the coarse material flap
	• The dirt hopper is full	• Empty the dirt hopper
	• The dirt hopper flap is not locked	• Lock the dirt hopper flap
	• The suction fan is contaminated	• Clean the suction fan
	• The dirt hopper and sieve are contaminated	• Clean the dirt hopper
	• The circulating water system is contaminated	• Clean the circulating water system
	• The vacuum system is clogged	• Clean the suction mouth with the auxiliary tool
	• The suction mouth sealing strips are defective	• Replace the suction mouth sealing strips
	• The suction duct seal is defective	• Replace the suction duct seal
	• The sweeping level is not adjusted correctly	• Adjust the sweeping level
	• The brush pressure is not correctly set	• Set the brush pressure
	• The hand suction hose is not correctly set on	• Set the hand suction hose
	• Seal the dirt hopper seal	• Replace the seal
	• The insert plate for the hand suction hose is still inserted	• Remove the insert plate
• Fan capacity has been set too high	• Light dirt clogs the fan filter	

**Hako GmbH
Hamburger Str. 209-239
23843 Bad Oldesloe, Germany**

declare in sole responsibility that the product

**Sweeping unit – Citymaster 2200 (Type: 1477)
Dirt hopper – Citymaster 2200 (Type: 1487)
Support – Citymaster 2200 (Type: 1408)**

on which this declaration is based corresponds with the relevant basic safety and health requirements of the EC Directive 2006/42/EC as well as the requirements according to 2014/30/EC.

The following standard(s) and technical specification(s) was/were referred to for the correct implementation of the safety and health requirements named in the EC Directive:

EN 13019

Name of the authorised person who compiles the technical documents for Hako:

Ludger Lüttel

Bad Oldesloe, 01.04.2016



Dr. Rainer Bavendiek
Development Manager

Hako

Clean ahead



Hako: environmentally friendly from the start

We want to leave a clean earth behind. Protecting resources, environment and the climate therefore governs all our activities. Independent institutes have confirmed this. You will find out more about our commitment on www.hako.com

Everywhere and quite close to you

Our efficient distribution and service network guarantees short journeys and fast help.

Purchasing, rental, leasing

We offer you a multitude of individual and attractive financing and procurement possibilities.

We are here for you day and night

The Hako stand-by and spare parts express service guarantees the highest availability.

Reliable cleanliness

Our machines satisfy your highest demands. Reliability thanks to quality "Made by Hako".

BLUECOMPETENCE
Alliance Member

Partner of the Engineering Industry Sustainability Initiative



Hako GmbH
Head Office
Hamburger Str. 209-239
23843 Bad Oldesloe
Germany
Tel. +49 (0) 4531-806 0
info@hako.com
www.hako.com